



CD/K/710:2010
ICS 67.120

EAST AFRICAN STANDARD

Sheep bleeding shackles — Specification

EAST AFRICAN COMMUNITY

Draft for comments only — Not to be cited as East African Standard

Foreword

Development of the East African Standards has been necessitated by the need for harmonizing requirements governing quality of products and services in East Africa. It is envisaged that through harmonized standardization, trade barriers which are encountered when goods and services are exchanged within the Community will be removed.

In order to meet the above objectives, the EAC Partner States have enacted an East African Standardization, Quality Assurance, Metrology and Test Act, 2006 (EAC SQMT Act, 2006) to make provisions for ensuring standardization, quality assurance, metrology and testing of products produced or originating in a third country and traded in the Community in order to facilitate industrial development and trade as well as helping to protect the health and safety of society and the environment in the Community.

East African Standards are formulated in accordance with the procedures established by the East African Standards Committee. The East African Standards Committee is established under the provisions of Article 4 of the EAC SQMT Act, 2006. The Committee is composed of representatives of the National Standards Bodies in Partner States, together with the representatives from the private sectors and consumer organizations. Draft East African Standards are circulated to stakeholders through the National Standards Bodies in the Partner States. The comments received are discussed and incorporated before finalization of standards, in accordance with the procedures of the Community.

Article 15(1) of the EAC SQMT Act, 2006 provides that "Within six months of the declaration of an East African Standard, the Partner States shall adopt, without deviation from the approved text of the standard, the East African Standard as a national standard and withdraw any existing national standard with similar scope and purpose".

East African Standards are subject to review, to keep pace with technological advances. Users of the East African Standards are therefore expected to ensure that they always have the latest versions of the standards they are implementing.

© East African Community 2010 — All rights reserved*

East African Community

P O Box 1096

Arusha

Tanzania

Tel: 255 27 2504253/8

Fax: 255-27-2504481/2504255

E-Mail: eac@eachq.org

Web: www.each.int

Introduction

In the preparation of this East African Standard, the following sources were consulted extensively:

IS 12190:1987(R2000), *Specification for Sheep Bleeding Shackles*

Codex Alimentarius website: http://www.codexalimentarius.net/mrls/pestdes/jsp/pest_q-e.jsp

USDA Foreign Agricultural Service website: <http://www.mrldatabase.com>

USDA Agricultural Marketing Service website: <http://www.ams.usda.gov/AMSV1.0/Standards>

USDA Plant Inspectorate Service website: http://www.aphis.usda.gov/import_export/plants

European Union: http://ec.europa.eu/sanco_pesticides/public

Assistance derived from these sources is hereby acknowledged.

Draft for comments only — Not to be cited as East African Standard

Contents

1	Scope	1
2	Normative references	1
3	Description	1
4	Material.....	1
5	Shape and dimensions	1
6	Constructional requirements.....	2
7	Workmanship and finish	2
8	Marking.....	2
9	Packing.....	3
10	Sampling	3
	Annex A (normative) Sampling of sheep bleeding shackles.....	4

Draft for comments only — Not to be cited as East African Standard

Sheep bleeding shackles — Specification

1 Scope

This East African Standard specifies material, dimensions and other requirements for sheep bleeding shackles.

2 Normative references

The following referenced documents are indispensable for the application of this document. For dated references, only the edition cited applies. For undated references, the latest edition of the referenced document (including any amendments) applies.

CAC/RCP 1, *Recommended international code of practice — General principles of food hygiene*

CD-K-670:2010, *Bovine (beef) meat — Carcasses and cuts*

CD-K-671:2010, *Caprine (goat) meat — Carcasses and cuts*

CD-K-672:2010, *Ovine (sheep) meat — Carcasses and cuts*

CD-K-673:2010, *Porcine (pig) meat — Carcasses and cuts*

CD-K-675:2010, *Edible meat co-products*

CD-K-697:2010, *Code of hygienic practice for meat*

CD/K/700:2010, *Ante-mortem and post-mortem inspection of meat animals — Code of practice*

EAS 11, *Galvanized plain and corrugated iron sheets — Specification*

ISO 630-1, *Structural steels — Part 1: Plates, wide flats, bars, sections and profiles*

ISO 2937, *Plain end seamless steel tubes for mechanical application*

ISO 11972, *Corrosion-resistant cast steels for general applications*

ISO 11973, *Heat-resistant cast steels and alloys for general applications*

ISO 16143-1, *Stainless steels for general purposes — Part 1: Flat products*

ISO 16143-2, *Stainless steels for general purposes — Part 2: Semi-finished products, bars, rods and sections*

3 Description

The sheep bleeding shackles shall consist of the shackle rod attached to a flat section with swivelling arrangements to suit the sliding rails.

4 Material

The flat section and the shackle rod shall be made from mild steel (ISO 630) or stainless steel (see ISO 16143).

5 Shape and dimensions

5.1 The shape and dimensions of the sheep bleeding shackles shall be as given in Figure 1.

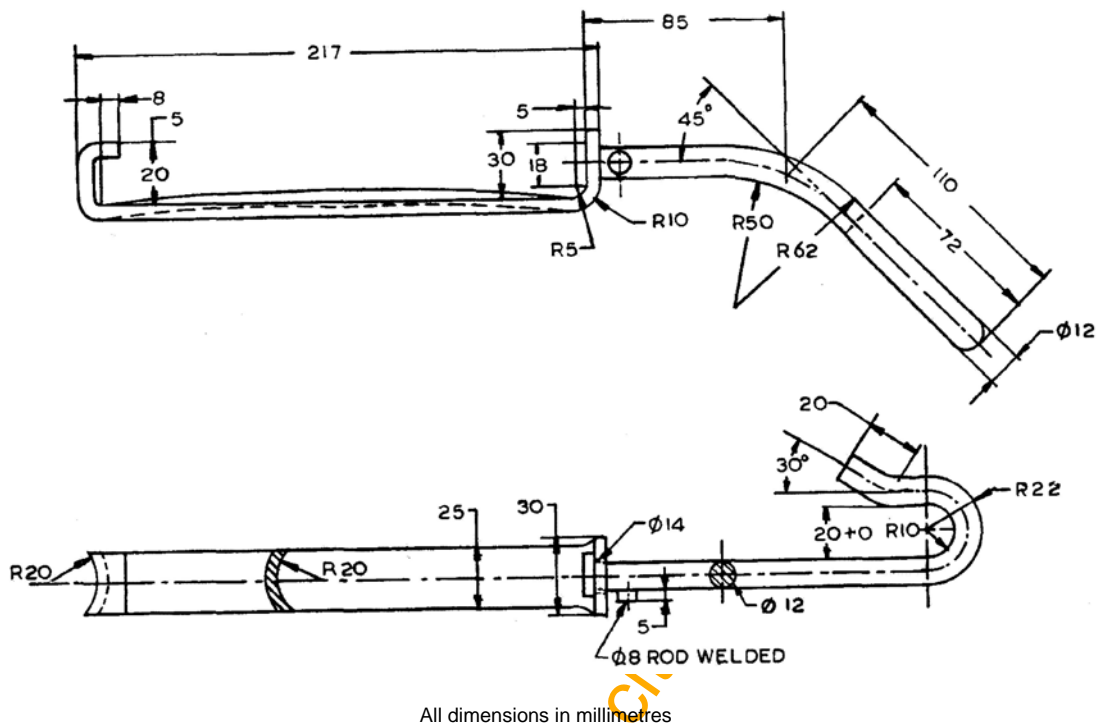

Figure 1 — Specification for sheep bleeding shackle

5.2 The tolerance for various dimensions shall be ± 5 percent.

6 Constructional requirements

6.1 The shape at the shackle end shall be as given in Figure 1 and the end shall be rounded smoothly.

6.2 The shackle shall not lose its shape when a mass of 100 kg is applied.

6.3 The shackle shall rotate freely on the flat section.

6.4 The flat section shall be selected taking into consideration, the dimensions of the overhead rail system. The flat section shall make minimum contact on the rail to ensure easy mobility.

7 Workmanship and finish

7.1 The sheep bleeding shackle shall be free from flaws, burrs, pits and sharp edges.

7.2 The welding shall be smooth.

7.3 The mild steel bleeding shackle shall be hot dip galvanized for protection from rust and corrosion.

8 Marking

8.1 Each sheep bleeding shackle shall be marked with the following information at a convenient place.

a) Manufacturer's name or trade-mark, if any:

- b) Year of Manufacture; and
- c) Batch or code number.

8.2 Standard marking — The product may be marked with a certification mark.

9 Packing

The sheep bleeding shackles shall be packed for safe handling in transit as agreed to between the manufacturer and the purchaser.

10 Sampling

The method for drawing representative samples of sheep bleeding shackles and the criteria for conformity shall be as given in Annex A.

Draft for comments only — Not to be cited as East African Standard

Annex A (normative)

Sampling of sheep bleeding shackles

A.1 Scale of sampling

A.1.1 Lot — In any consignment of the sheep bleeding shackle of the same type, shape, size and belonging to the same batch of manufacture shall be grouped together to constitute a lot.

A.1.2 For ascertaining the conformity of the material to the requirements of this specification, samples shall be tested from each lot separately.

A.1.3 The number of sheep bleeding shackles to be selected from a lot shall depend on the size of the lot and shall be according to col 1 and 2 of Table 1.

Table 1 — Scale of sampling and permissible number of defectives

Number of sheep bleeding shackles in a lot	For visual and dimensional tests		Number of shackles in the sub-sample for bend test
	Sample size	Permissible number of defectives	
(1)	(2)	(3)	(4)
Up to 100	5	0	2
101 to 300	13	1	2
301 to 500	32	3	3
501 to 1000	50	5	5
1001 and above	80	7	8

A.1.3.1 These sheep bleeding shackles shall be selected at random from the lot.

A.2 Number of tests and criteria for conformity

A.2.1 All sheep bleeding shackles selected according to A.1.3 shall be examined for all the visual and dimensional requirements (see 5.1, 6.1, 6.3, 6.4, 7.1 and 7.2). A gambrel failing to satisfy any one or more of these requirements shall be considered as defective. The lot shall be considered as conforming to these requirements if the number of defectives found in the sample is less than or equal to the corresponding number of permissible number of defectives given in col 3 of Table 1.

A.2.2 The lot having been found satisfactory according to A.2.1 shall be further subjected to bend test given in 6.2. For this purpose, a sub-sample of size given in col 4 of Table 1 shall be taken from the lot. These shackles may be selected from those already examined according to A.2.1 and found satisfactory. The lot shall be declared as conforming to the requirements of this specification if none of the gambrels subjected to the bend test fails to satisfy the requirements of this test.

Draft for comments only — Not to be cited as East African Standard