



## **EAST AFRICAN STANDARD**

---

**Fishing nets — Determination of change in length of netting yarns after water immersion**

**EAST AFRICAN COMMUNITY**

---

## Foreword

Development of the East African Standards has been necessitated by the need for harmonizing requirements governing quality of products and services in East Africa. It is envisaged that through harmonized standardization, trade barriers which are encountered when goods and services are exchanged within the Community will be removed.

In order to meet the above objectives, the EAC Partner States have enacted an East African Standardization, Quality Assurance, Metrology and Test Act, 2006 (EAC SQMT Act, 2006) to make provisions for ensuring standardization, quality assurance, metrology and testing of products produced or originating in a third country and traded in the Community in order to facilitate industrial development and trade as well as helping to protect the health and safety of society and the environment in the Community.

East African Standards are formulated in accordance with the procedures established by the East African Standards Committee. The East African Standards Committee is established under the provisions of Article 4 of the EAC SQMT Act, 2006. The Committee is composed of representatives of the National Standards Bodies in Partner States, together with the representatives from the private sectors and consumer organizations. Draft East African Standards are circulated to stakeholders through the National Standards Bodies in the Partner States. The comments received are discussed and incorporated before finalization of standards, in accordance with the procedures of the Community.

Article 15(1) of the EAC SQMT Act, 2006 provides that "Within six months of the declaration of an East African Standard, the Partner States shall adopt, without deviation from the approved text of the standard, the East African Standard as a national standard and withdraw any existing national standard with similar scope and purpose".

East African Standards are subject to review, to keep pace with technological advances. Users of the East African Standards are therefore expected to ensure that they always have the latest versions of the standards they are implementing.

© East African Community 2010 — All rights reserved\*

East African Community

P O Box 1096

**Arusha**

Tanzania

Tel: 255 27 2504253/8

Fax: 255-27-2504481/2504255

E-Mail: [eac@eachq.org](mailto:eac@eachq.org)

Web: [www.each.int](http://www.each.int)

---

\* © 2010 EAC — All rights of exploitation in any form and by any means reserved worldwide for EAC Partner States' NSBs.

## Introduction

In the preparation of this East African Standard, the following sources were consulted extensively:

KS 08-1129-1:1992, *Test method for fishing nets — Part 1: Determination of change in length after water immersion*

ISO 3090:1974, *Ropes and cordage — Netting yarns — Determination of change in length after immersion in water*

IS 4303-1:1975, *Code of hygienic conditions for fish industry — Part 1: Pre-processing stage*

IS 4303-2:1975, *Code of hygienic conditions for fish industry — Part 2: Canning stage*

Codex Alimentarius website: [http://www.codexalimentarius.net/mrls/pestdes/jsp/pest\\_q-e.jsp](http://www.codexalimentarius.net/mrls/pestdes/jsp/pest_q-e.jsp)

USDA Foreign Agricultural Service website: <http://www.mrlatabase.com>

USDA Agricultural Marketing Service website: <http://www.ams.usda.gov/AMSV1.0/Standards>

USDA Plant Inspectorate Service website: [http://www.aphis.usda.gov/import\\_export/plants](http://www.aphis.usda.gov/import_export/plants)

European Union: [http://ec.europa.eu/sanco\\_pesticides/public](http://ec.europa.eu/sanco_pesticides/public)

Assistance derived from these sources is hereby acknowledged.

---

**INTERNATIONAL STANDARD**



**3090**

---

INTERNATIONAL ORGANIZATION FOR STANDARDIZATION • МЕЖДУНАРОДНАЯ ОРГАНИЗАЦИЯ ПО СТАНДАРТИЗАЦИИ • ORGANISATION INTERNATIONALE DE NORMALISATION

---

**Netting yarns — Determination of change in length  
after immersion in water**

*Fils pour filets — Détermination de la variation de longueur après immersion dans l'eau*

**First edition — 1974-07-01**

---

**UDC 677.061 : 677.66 : 531.71**

**Ref. No. ISO 3090-1974 (E)**

**Descriptors :** textiles, nets, yarns, tests, dimensional stability, determination, immersion tests.

## FOREWORD

ISO (the International Organization for Standardization) is a worldwide federation of national standards institutes (ISO Member Bodies). The work of developing International Standards is carried out through ISO Technical Committees. Every Member Body interested in a subject for which a Technical Committee has been set up has the right to be represented on that Committee. International organizations, governmental and non-governmental, in liaison with ISO, also take part in the work.

Draft International Standards adopted by the Technical Committees are circulated to the Member Bodies for approval before their acceptance as International Standards by the ISO Council.

International Standard ISO 3090 was drawn up by Technical Committee ISO/TC 38, *Textiles*, and circulated to the Member Bodies in March 1973.

It has been approved by the Member Bodies of the following countries :

Australia	Germany	Romania
Belgium	Hungary	South Africa, Rep. of
Brazil	India	Spain
Bulgaria	Israel	Sweden
Czechoslovakia	Italy	Switzerland
Denmark	Japan	Thailand
Egypt, Arab Rep. of	New Zealand	Turkey
Finland	Norway	United Kingdom
France	Poland	

The Member Body of the following country expressed disapproval of the document on technical grounds :

Canada

# Netting yarns – Determination of change in length after immersion in water

## 1 SCOPE AND FIELD OF APPLICATION

This International Standard specifies a method for determining the change in length of netting yarns after immersion in water.

## 2 REFERENCES

ISO 139, *Textiles – Standard atmospheres for conditioning and testing*.

ISO 858, *Netting yarns for fishing nets – Designation in the Tex system*.

## 3 PRINCIPLE

Immersion in water, at a given temperature, of a length of netting yarn on which two marks have been made at a prescribed distance apart. Measurement of the change in length between the two marks.

## 4 APPARATUS

The apparatus shown in the figure below shall be used. It shall allow the measurement of a length of yarn of

$1\,000 \pm 1$  mm with an accuracy of 1 mm and the application of a tension by means of a weight suspended from one end of the yarn.

The most important components of the apparatus are :

- a hook or a clamp at one end to fasten the netting yarn to be tested;
- a free-turning pulley on the other end, on which the specimen is placed and tensioned;
- a measuring-scale graduated in centimetres and millimetres;
- two double-indicator devices movable on a metal rod. The horizontal pointers give the measured value on the scale when the vertical pointers above them are in contact with the marks on the specimen.

## 5 SAMPLING

Sampling shall be carried out in accordance with recognized national standards or in a manner agreed between the interested parties.

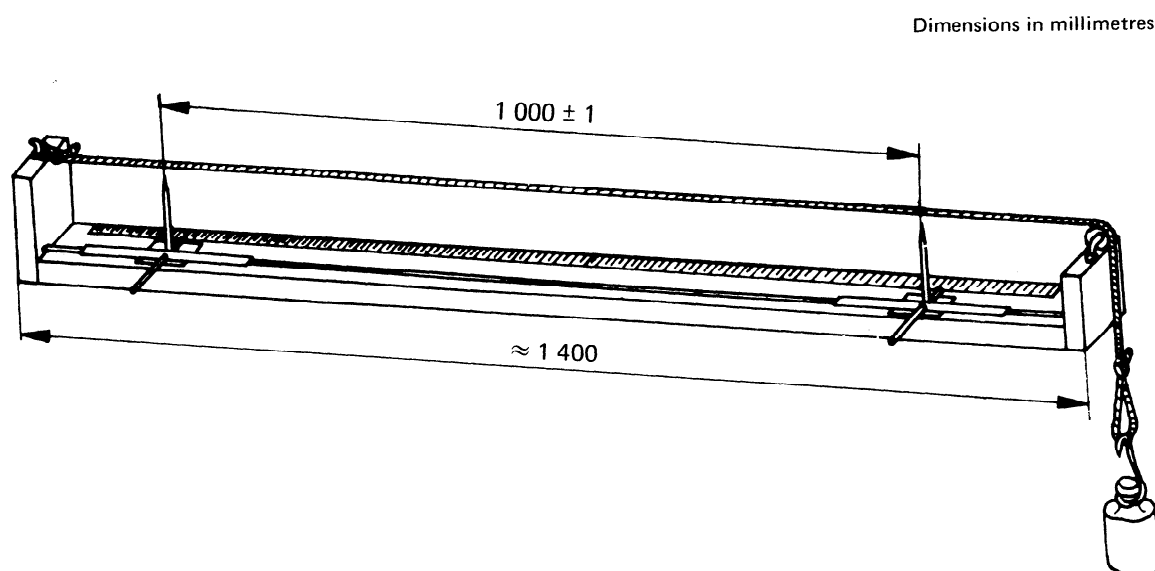

FIGURE – Apparatus for determining the change in length

## 6 PREPARATION OF SPECIMENS

6.1 The specimens shall be removed from the package or the netting, before exposure in the standard atmosphere, in such a manner that there is no alteration in the construction.

6.2 The netting yarn shall be cut in pieces of appropriate length for the measuring apparatus (see clause 4). The ends of each length shall be melted or knotted.

6.3 The single pieces of netting yarn to be measured shall be taken at random from the package or the netting.

## 7 REQUIREMENTS FOR TESTING

### 7.1 Atmosphere for testing

Before immersion in water, the specimens shall be exposed for a period of 24 h to one of the standard atmospheres for testing specified in ISO 139.

### 7.2 Testing in the wet state

7.2.1 All specimens to be tested in the wet state shall be immersed in tap water, without wetting agents, at a temperature of  $20 \pm 2$  °C for a period of not less than 12 h.

7.2.2 By agreement between the interested parties, a shorter wetting time with the addition of a wetting agent may be used.

### 7.3 Distance between marks

The distance between the marks on the specimen shall be  $1\ 000 \pm 1$  mm.

### 7.4 Tension

The tension used for all measurements shall correspond to the weight of  $250 \pm 25$  m of the netting yarn to be tested. The tension shall be constant for all specimens taken from any one sample and shall be applied in such a manner that sudden tautening of the yarn is avoided.

## 8 NUMBER OF TESTS

Not less than five specimens of each sample shall be tested. If a distinct confidence interval for the mean value is prescribed, as many additional tests are to be carried out as are necessary to secure this confidence interval.

## 9 PROCEDURE

9.1 Take precautions to ensure that the construction of the specimen is not altered during all handling and measuring of the specimens.

9.2 Fasten one end of the conditioned specimen of the netting yarn of sufficient length to the hook or grip of the apparatus and hang the weight at the other end (see the figure).

9.3 Indicate the length to be measured on the specimens by two marks,  $1\ 000 \pm 1$  mm apart. Measure the distance between the marks on each specimen to an accuracy of  $\pm 1$  mm and record the result (*A*).

9.4 Immerse each specimen in water (see 7.2) and remeasure the distance between the marks immediately after removal from the water to an accuracy of  $\pm 1$  mm and record the result (*B*).

9.5 Dry the specimens for 24 h freely suspended in the standard atmosphere for testing. Measure again the distance between the marks on each specimen to an accuracy of  $\pm 1$  mm and record the result (*C*).

## 10 CALCULATION AND EXPRESSION OF RESULTS

Calculate the arithmetic mean of the recorded measurements at each stage (*A*, *B* and *C*) and designate the means as  $A_1$ ,  $B_1$  and  $C_1$ . Using these arithmetic means, calculate the changes in length caused by wetting ( $B_1 - A_1$ ) and by drying again ( $C_1 - A_1$ ). In each case, express the changes in length as percentages of the initial mean conditioned length ( $A_1$ ).

## 11 TEST REPORT

The test report shall include the following particulars :

- a) a statement that the tests were performed in accordance with this International Standard;
- b) the date of the test;
- c) the type and designation of the netting yarn, according to ISO 858;
- d) the number of specimens tested;
- e) the average changes in length caused by wetting ( $B_1 - A_1$ ) and drying again ( $C_1 - A_1$ ), measured both in the wet state and in the dried state, expressed as percentages of the initial distance between the marks ( $A_1$ );
- f) if required, the coefficient of variation of the dimensional changes and the confidence interval.

*Draft for comments only - Not to be cited as East African Standard*