



CD/K/170:2009
ICS 23.060.30

EAST AFRICAN STANDARD

Copper alloy gate valves — Heavy duty — Specification

Draft for comments only — Not to be cited as East African Standard

EAST AFRICAN COMMUNITY

Foreword

Development of the East African Standards has been necessitated by the need for harmonizing requirements governing quality of products and services in East Africa. It is envisaged that through harmonized standardization, trade barriers which are encountered when goods and services are exchanged within the Community will be removed.

In order to meet the above objectives, the EAC Partner States have enacted an East African Standardization, Quality Assurance, Metrology and Test Act, 2006 (EAC SQMT Act, 2006) to make provisions for ensuring standardization, quality assurance, metrology and testing of products produced or originating in a third country and traded in the Community in order to facilitate industrial development and trade as well as helping to protect the health and safety of society and the environment in the Community.

East African Standards are formulated in accordance with the procedures established by the East African Standards Committee. The East African Standards Committee is established under the provisions of Article 4 of the EAC SQMT Act, 2006. The Committee is composed of representatives of the National Standards Bodies in Partner States, together with the representatives from the private sectors and consumer organizations. Draft East African Standards are circulated to stakeholders through the National Standards Bodies in the Partner States. The comments received are discussed and incorporated before finalization of standards, in accordance with the procedures of the Community.

Article 15(1) of the EAC SQMT Act, 2006 provides that "Within six months of the declaration of an East African Standard, the Partner States shall adopt, without deviation from the approved text of the standard, the East African Standard as a national standard and withdraw any existing national standard with similar scope and purpose".

East African Standards are subject to review, to keep pace with technological advances. Users of the East African Standards are therefore expected to ensure that they always have the latest versions of the standards they are implementing.

© East African Community 2010 — All rights reserved*

East African Community

P O Box 1096

Arusha

Tanzania

Tel: 255 27 2504253/8

Fax: 255-27-2504481/2504255

E-Mail: eac@eachq.org

Web: www.each.int

* © 2010 EAC — All rights of exploitation in any form and by any means reserved worldwide for EAC Partner States' NSBs.

Introduction

In the preparation of this East African Standard, the following source was consulted extensively:

SANS 776:2005, *Copper alloy gate valves — Heavy duty — Specification*

Assistance derived from this source and others inadvertently not mentioned is hereby acknowledged.

Draft for comments only — Not to be cited as East African Standard

This standard may only be used and printed by approved subscription and freemailing clients of the SABS.

ICS 23.060.30; 77.150.30

ISBN 0-626-16671-3

SANS 776:2005

Edition 3.1

Any reference to SABS 776 is deemed
to be a reference to this standard
(Government Notice No. 1373 of 8 November 2002)

SOUTH AFRICAN NATIONAL STANDARD

Copper alloy gate valves — Heavy duty

Published by Standards South Africa
1 dr lategan road groenkloof ☒ private bag x191 pretoria 0001
tel: 012 428 7911 fax: 012 344 1568 international code + 27 12
www.stansa.co.za
© Standards South Africa

standards
SouthAfrica
(a division of SABS)

SANS 776:2005
Edition 3.1

Table of changes

Change No.	Date	Scope
Amdt 1	2005	Amended to update referenced standards, to redefine "acceptable" and to update the marking requirements.

Abstract

Specifies requirements for heavy duty copper gate valves (with screwed ends and rising or non-rising stems) of nominal size 8 mm to 100 mm and that are suitable for use at service temperatures up to and including 260 °C. They can be used at pressures higher than their primary service pressures but then at correspondingly lower service temperatures.

Keywords

construction, copper, copper alloys, dimensions, fluid equipment, gate valves, marking, non-ferrous alloys, packaging, performance, performance testing, pressure testing, specifications, valves.

Foreword

This South African standard was approved by National Committee StanSA SC 5120.12H, *Water and sanitation – Equipment and systems – Plumbing components*, in accordance with procedures of Standards South Africa, in compliance with annex 3 of the WTO/TBT agreement.

This edition cancels and replaces edition 3 (SABS 776:2000).

A vertical line in the margin shows where the text has been technically modified by amendment No. 1.

Annexes A and B are for information only.

Contents

	Page
Abstract	
Keywords	
Foreword	
1 Scope	3
2 Normative references	3
3 Definitions	4
4 General requirements	4
5 Materials, construction and performance	5
6 Inspection and methods of test	10
6.1 Inspection	10
6.2 Performance test for valves	10
6.3 Strength test on handwheels	11
6.4 Test for dezincification resistance	12
7 Packing and marking	12
Figures 1 and 2	13-14
Annex	
A Notes to purchasers	15
B Quality verification of heavy duty copper alloy gate valves	15
Bibliography	15

This standard may only be used and printed by approved subscription and freemailing clients of the SABS.

SANS 776:2005
Edition 3.1

This page is intentionally left blank

Copper alloy gate valves — Heavy duty

1 Scope

This standard specifies the requirements for, heavy duty copper alloy gate valves (with screwed ends and rising or non-rising stems) of nominal size 8 mm to 100 mm and that are suitable for use at service temperatures up to and including 260 °C. They can be used at pressures higher than their primary service pressures but then at correspondingly lower service temperatures, as indicated in table 1.¹⁾

2 Normative references

The following standards contain provisions which, through reference in this text, constitute provisions of this standard. All standards are subject to revision and, since any reference to a standard is deemed to be a reference to the latest edition of that standard, parties to agreements based on this standard are encouraged to take steps to ensure the use of the most recent editions of the standards indicated below. Information on currently valid national and international standards can be obtained from Standards South Africa.

BS 2872, Specification for copper and copper alloy forging stock and forgings.	Amdt 1
BS 2874, Specification for copper and copper alloy rods and sections (other than forging stock).	Amdt 1
EN 12164, <i>Copper and copper alloys – Rod for free machining purposes.</i>	Amdt 1
EN 12420, <i>Copper and copper alloys – Forgings.</i>	Amdt 1
SANS 200 (SABS 200), <i>Copper alloy ingots and castings (metric units).</i>	
SANS 1067-1 (SABS 1067-1), <i>Copper-based fittings for copper tubes – Compression fittings.</i>	
SANS 1109-1 (SABS 1109-1), <i>Pipe threads where pressure-tight joints are made on the threads – Part 1: Dimensions, tolerances and designation.</i>	
SANS 1700, <i>Fasteners.</i>	
SANS 6509 (SABS ISO 6509), <i>Corrosion of metals and alloys – Determination of dezincification resistance of brass.</i>	

1) The pressure/temperature rating applicable to a valve depends on the materials used in the manufacture of the valve components.

SANS 776:2005
Edition 3.1

3 Definitions

For the purposes of this standard, the following definitions apply:

3.1

acceptable

acceptable to the authority administering this standard

Amdt 1

3.2

class rating

maximum working pressure (in kPa) for which the valve is designed

3.3

cold service

conditions where the temperature of the liquid passing through the valve does not exceed 38 °C

3.4

heavy duty valve

valve that is suitable for use at temperatures of up to 260 °C

3.5

hot water

of a temperature above 38 °C but not higher than 95 °C

3.6

primary service pressure

maximum non-shock working pressure permissible for a valve at the highest permissible service temperature, i.e. 260 °C

4 General requirements

4.1 General

The valves shall have wedge-shaped gates (solid or split) that are operated by an inside screw, and shall be of the rising stem type or the non-rising stem type, as required (see figure 1 and 2).

A heavy duty valve shall include

- a) a bonnet that is fitted to the inside or the outside of the valve body by means of a fixing screw thread, or by a bolted flange (see figure 1 and 2),
- b) a gland packing (i.e. not an "O" ring) complete with a gland ring and a gland nut of dimensions suitable to keep the gland packing in position and prevent leakage from the valve, and
- c) mating shoulders (on the stem and in the bonnet) that will prevent the spindle from being blown out from the valve.

4.2 Service temperature

Valves shall be capable of generally operating at service temperatures up to and including 200 °C or otherwise in excess of 200 °C when so required. Valves for operation at service temperatures in excess of 200 °C shall be manufactured from leaded gun metal (see table 2) and shall be marked with the temperature 260 °C.

4.3 Class rating

Valves shall be of class 16, 20 or 32 as specified.

4.4 Pressure/temperature rating

The working pressure of the valve shall be as given in columns 2, 3 and 4 of table 1, appropriate to the temperatures given in column 1.

4.5 Size

The nominal size of a valve shall be one of those given in column 1 of table 3, as required.

Table 1 — Pressure/temperature ratings

1	2	3	4
Maximum temperature °C	Working pressure ¹⁾		
	Class 16	Class 20	Class 32
38	1 600	2 000	3 200
95	1 600	2 000	3 200
180	1 600	2 000	3 200
200	1 500	1 800	3 000
220	1 300	1 600	2 600
240	1 100	1 400	2 100
260 ²⁾	800 ³⁾	1 000 ³⁾	1 600 ³⁾

1) The non-shock working pressure.
2) Highest permissible service temperature.
3) Primary service pressure.

5 Materials, construction and performance

5.1 Materials

5.1.1 Type of materials

The materials of the components shall be as given in table 2.

5.1.2 Dezincification resistance

Copper alloy components in direct contact with the water shall, when tested in accordance with 6.4, show a penetration not exceeding 250 µm.

SANS 776:2005
Edition 3.1

Table 2 — Type of materials

1	2	3	4	5
Component ¹⁾	Material	Specification	Code No.	Designation
Valve body	Leaded gunmetal Leaded brass	SANS 200 SANS 200	3D 9A*	Cu-Sn5 Zn5 Pb5 Cu-Zn34 Pb2
Bonnet, union nut, stuffing box, gland, gland nut	Leaded gunmetal Leaded brass Leaded brass	SANS 200 SANS 200 EN 12420	3D 9A* CZ122*	Cu-Sn5 Zn5 Pb5 Cu-Zn34 Pb2 Cu-Zn40 Pb2
Stem	Leaded gunmetal Leaded brass Leaded brass Leaded brass An acceptable stainless steel	SANS 200 SANS 200 EN 12164 EN 12164	3D 9A* CZ122* CZ121*	Cu-Sn5 Zn7 Pb5 Cu-Zn34 Pb2 Cu-Zn40 Pb2 Cu-Zn39 Pb3
Wedge (gate), body seat ring	Leaded gunmetal Leaded brass	SANS 200 SANS 200 EN 12420	3D 9A* CZ122	Cu-Sn5 Zn5 Pb5 Cu-Zn34 Pb2 Cu-Zn40 Pb2
	An acceptable copper nickel alloy An acceptable stainless steel			
Bolts, studs, stud- bolts	Steel Naval brass Leaded brass	SANS 1700 EN 12164 EN 12164	CZ112 CZ121*	Cu-Zn37 Sn1 Cu-Zn39 Pb3
Handwheel	Steel, cast aluminium or malleable cast iron, as specified.			
Handwheel nuts and set-screws	Leaded brass	EN 12164	CZ121*	Cu-Zn39 Pb3
Gland packing and gaskets	To suit service conditions			
1) See figures 1 and 2.				
*Not for service temperatures above 200 °C.				

Amdt 1

5.2 Bodies

5.2.1 General

5.2.1.1 The castings shall be free from porosity, laps, blowholes, and pitting.

5.2.1.2 The bore shall be circular, and of diameter not, at any point, less than the appropriate minimum given in column 2 of table 3.

5.2.1.3 The wall thickness at any point of the body shall be at least equal to the appropriate minimum given in columns 3 to 5 of table 3, and the body shall be so designed and made that there will be no internal interference and no shouldering when the valve is assembled to pipes of which the coupling threads are screwed to the slackest condition allowed by SANS 1109-1.

5.2.1.4 There shall be enough clearance between the gate (in its closed position) and the bottom side of the body to ensure full and continued effective use of the seating area.

Table 3 — Essential dimensions of body and bonnet

Dimensions in millimetres

1	2	3	4	5
Nominal valve size mm	Minimum bore	Minimum wall thickness		
		Class		
		16	20	32
8	6	1,8	1,9	2,1
10	10	1,9	2,0	2,2
15	13	2,0	2,1	2,6
20	20	2,1	2,2	2,8
25	25	2,2	2,5	3,4
32	32	2,4	2,6	3,7
40	38	2,5	2,8	3,9
50	50	2,9	3,1	4,6
65	63	3,1	3,5	5,2
80	75	3,4	3,8	5,5
100	98	4,7	5,5	8,0

5.2.2 Ends

5.2.2.1 Valve ends shall be screwed internally or externally, as required (see annex A).

5.2.2.2 Screw threads shall comply with SANS 1109-1 and shall be parallel for external threads and parallel or tapered for internal threads, or shall comply with the requirements given for the coupling threads in SANS 1067-1.

5.2.2.3 The wall thickness (measured from the basic major diameter of the thread) at the outer faces of screwed ends shall be at least equal to the appropriate minimum given in table 4.

Table 4 — Minimum wall thicknesses of internally screwed ends

Dimensions in millimetres

1	2
Nominal valve size	Minimum wall thickness, (all classes)
8	3,1
10	3,3
15	3,6
20	4,0
25	4,5
32	5,0
40	5,3
50	6,0
65	6,7
80	7,3
100	9,5

SANS 776:2005

Edition 3.1

5.3 Guides

All valves shall have guides. The guides shall be smooth and true, and such that the seating face of the wedge cannot touch the body seating face until near the point of closure.

5.4 Body seats

Body seats shall be integral with the body or shall be in the form of acceptably fitted renewable seat rings, and shall be so designed as to allow for wear. Seating faces shall be finished smooth.

The thickness of the metal of a body seat that is integral with the body and of the metal supporting a renewable ring type seat, shall be at least equal to the appropriate minimum wall thickness given in table 3.

5.5 Gates

5.5.1 Type

Gates shall be of the solid wedge or split wedge type as specified.

5.5.2 Operation

The operation of a gate shall be such that when the gate is in the fully raised position, it is clear of the seat bore.

5.5.3 Wedges

Wedges shall have acceptable means of attachment to the stem, and shall be so designed as to allow for wear.

5.6 Bonnets

5.6.1 Wall thickness

The wall thickness at any part of a bonnet shall be at least equal to the appropriate minimum given in columns 3 to 5 of table 3.

5.6.2 Type of bonnet-to-body connection

The type of connection between the bonnet and the body shall be one of the following as specified:

- a) screwed type (internal thread on bonnet); or
- b) union type; or
- c) bolted type.

5.6.3 Surfaces of joint

The surfaces forming the bonnet-to-body joint shall be machined. The joint shall be metal-to-metal or shall be fitted with a gasket.

5.7 Glands

Glands shall be screwed and shall consist of a gland, a gland packing and a gland nut. The bearing surface of the glands shall be internally chamfered to ensure satisfactory compression of the packing against the stem.

Valves shall be so designed that with the valve in fully closed position, the gland and gland packing can be removed for service.

5.8 Stems

5.8.1 General

Stems shall be in one piece and shall be long enough to ensure that there is acceptable hand-clearance between the handwheel and the top of the gland nut when the valve is in the fully closed position.

5.8.2 Threads on stems

The actuating thread on a stem shall be a square thread or a trapezoidal thread.

5.8.3 Direction of closing

The valve will be closed by turning the handwheel in a direction that is clockwise when it (the valve) is viewed from above the handwheel.

5.8.4 Stem diameter

The diameter of the valve stem, measured at the following position(s), shall be at least equal to the appropriate minimum given in table 5:

- a) **Non-rising stems:** at the gland and at the major diameter of the actuating thread; and
- b) **Rising stems:** at the gland.

Table 5 — Minimum stem diameters

Dimensions in millimetres

1	2	3	4
Nominal valve size	Minimum stem diameter		
	Class		
	16	20	32
8	5,8	6,2	6,6
10	6,2	7,0	7,5
15	7,0	7,8	8,5
20	7,9	8,6	9,4
25	9,4	10,2	11,0
32	10,2	11,1	12,0
40	11,1	11,8	12,5
50	12,6	13,4	14,3
65	14,2	15,0	15,2
80	15,8	16,6	17,4
100	17,5	—	—

SANS 776:2005

Edition 3.1

5.9 Handwheels

When tested in accordance with 6.3, the handwheel of a valve shall not, in either test, break or be so distorted as to affect its serviceability.

5.10 Bolts, stud-bolts, studs, set screws and nuts

The dimensions of bolts, stud-bolts, studs, set screws, and nuts shall conform to the relevant values given in SANS 1700.

5.11 Performance

5.11.1 Body strength

The strength and construction of the body shall be such that when the valve is tested in accordance with 6.2.1, there shall be no distortion or failure of any component and no leakage through the valve body or any joint between component parts.

5.11.2 Gate leakage

The finish of the gate seats shall be such that when the valve is tested in accordance with 6.2.2, the rate of leakage of the seat, when relevant, does not exceed the rate derived from $0,01 \times \text{nominal size mm}^3/\text{sec}$.

5.11.3 Torque resistance of stem, stem thread and yoke

The strength of the stem, stem thread and yoke shall be such that, when the valve is tested in accordance with 6.2.3, the spindle does not break, the thread does not strip and the yoke does not break or permanently distort.

6 Inspection and methods of test

6.1 Inspection

Visually examine and measure each valve in the sample for compliance with all the applicable requirements of clause 4 and 5 for which tests to assess compliance are not given in 6.2, 6.3 and 6.4.

6.2 Performance test for valves

6.2.1 Body strength test

Subject the valve (with the gate in the fully open position and the gland nut well tightened) to the appropriate hydrostatic pressure given in column 2 of table 6 for a period of 1 min and then, while still under pressure, inspect the valve for compliance with 5.11.1.

6.2.2 Gate seat leakage test

Subject the valve, with the gate in the fully closed position, to the appropriate hydrostatic pressure given in column 3 of table 6. Apply the pressure successively to each side of the gate (the other end of the valve being left open to the atmosphere). In each case, after a period of 1 min and with the valve still under pressure, inspect the gate seat for leaks and check for compliance with 5.11.2.

Table 6 — Hydrostatic test pressures

1	2	3
Class of valve	Test pressure	
	kPa	
	Body test	Seat test
16	2 400	1 600
20	3 000	2 000
32	4 800	3 200

6.2.3 Torque resistance test for stems, stem threads and yokes

Fully close the valve, remove the valve handle and apply to the spindle a closing torque equal in value to that given in column 2 of table 6, appropriate to the size given in column 1. Maintain the torque for $30 \text{ s} \pm 5 \text{ s}$. Remove the torque and check the stem, stem thread and yoke for compliance with 5.11.3.

Table 7 — Strength of spindles and handwheels

1	2	3	4
Nominal valve size	Torque on spindles	Torque on handwheels	Bending moment
mm	N.m	N.m	N.m
8	12	25	90
10	12	25	90
15	12	25	90
20	15	30	100
25	20	35	130
32	25	40	160
40	35	50	180
50	40	60	220
65	60	70	270
80	60	70	270
100	60	70	270

6.3 Strength test on handwheels

6.3.1 Torque test

With the body of valve securely clamped and the valve in the fully closed position, apply to the rim of the handwheel a torque equal to that given in column 3 of table 7 appropriate to the size of valve given in column 1 and inspect for failure.

6.3.2 Bending test

With the body of the valve securely clamped and the valve in the fully closed position, subject the handwheel to a bending moment equal to that given in column 4 of table 7, appropriate to the size of valve given in column 1 applied at right angles to the plane of the top of the handwheel, and check for compliance with 5.9.

SANS 776:2005

Edition 3.1

6.4 Test for dezincification resistance

Carry out the test given in SANS 6509 and check for compliance with the requirements of 5.1.2.

7 Packing and marking

7.1 Packing

Before being packed, the valves shall be thoroughly drained and their gates shall be fully closed. The valves shall be so packed or prepared for despatch as to minimize the possibility of any component (inner or outer) being damaged during normal conditions of storage and transportation. Only valves of the same class, type, materials, construction, and nominal size shall be packed together in a bulk container.

7.2 Marking

7.2.1 Valves

The following information shall be clearly and permanently marked on each valve:

- a) manufacturer's name or trade mark;
- b) the class number;
- c) when relevant, the temperature 260 °C (see 4.2); and
- d) the letters "DR" (that indicate that the copper alloy is dezincification resistant).

7.2.2 Containers

Each container shall be marked with the type of valve and the information required in terms of 7.2.1.

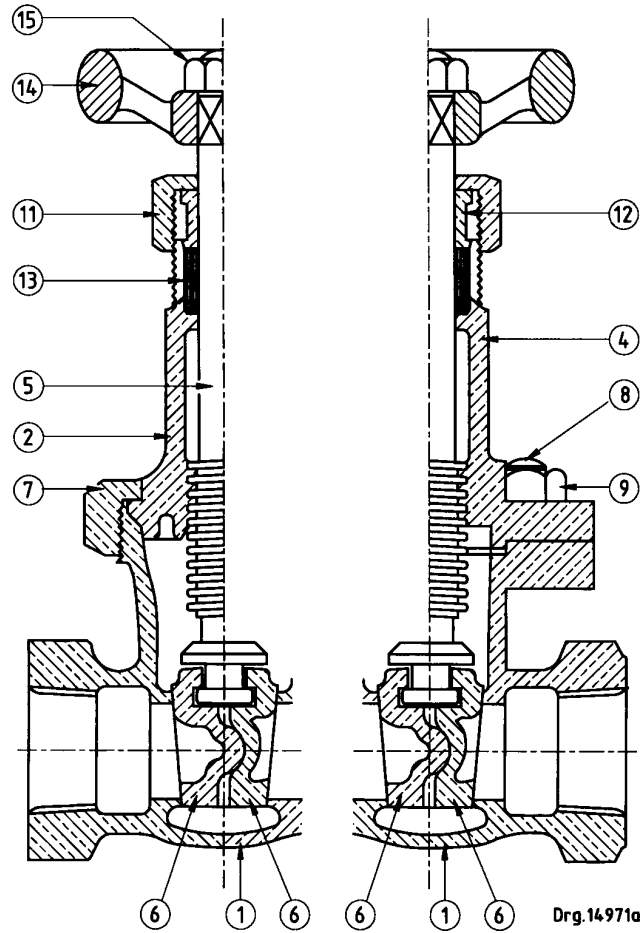

Name of part

- 1 Body
- 2 Bonnet (union type)
- 3 Bonnet (screwed type – internal or external)

- 5 Stem (inside screw type)
- 6 Wedge
- 7 Bonnet union nut

- 10 Stuffing box
- 11 Gland nut
- 12 Gland

- 13 Gland packing
- 14 Handwheel
- 15 Handwheel nut

Figure 1 — Inside screw, solid or split wedge, non-rising stem

SANS 776:2005
Edition 3.1

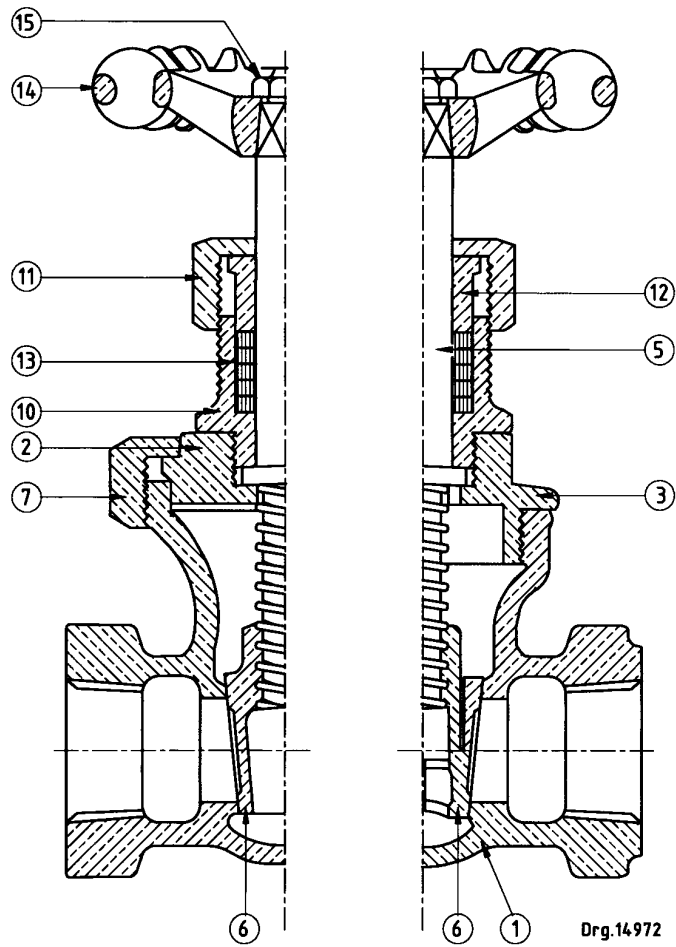

Name of part

- | | |
|----|--|
| 1 | Body |
| 2 | Bonnet (union type) |
| 4 | Bonnet (bolted type) |
| 5 | Stem (inside screw type) |
| 6 | Wedge |
| 7 | Bonnet union nut |
| 8 | Bonnet stud (or stud-bolt, bolt, or set screw) |
| 9 | Nut for bonnet stud |
| 11 | Gland nut |
| 12 | Gland |
| 13 | Gland packing |
| 14 | Handwheel |
| 15 | Handwheel nut |

Figure 2 — Inside screw, split wedge, rising stem

Annex A
(informative)

Notes to purchasers

The following requirements should be specified in tender invitations and in each order or contract:

- a) The type (see 4.1)
- b) The service temperature (see 4.2)
- c) The class (see 4.3)
- d) The nominal size or the size designation (see 4.5)
- e) The material of the handwheel (see table 2)
- f) Whether screwed internally or externally (see 5.2.2.1)
- g) The type of gate (see 5.5.1)
- h) The type of connection between the body and bonnet (see 5.6.2)

Annex B
(informative)

**Quality verification of heavy duty
copper alloy gate valves**

When a purchaser requires ongoing verification of the quality of heavy duty copper alloy gate valves, it is suggested that, instead of concentrating solely on evaluation of the final product, he also direct his attention to the manufacturer's quality system. In this connection it should be noted that SANS 9001 covers the provision of an integrated quality management system. **Amdt 1**

Bibliography

SANS 9001, *Quality management systems – Requirements*.

Amdt 1

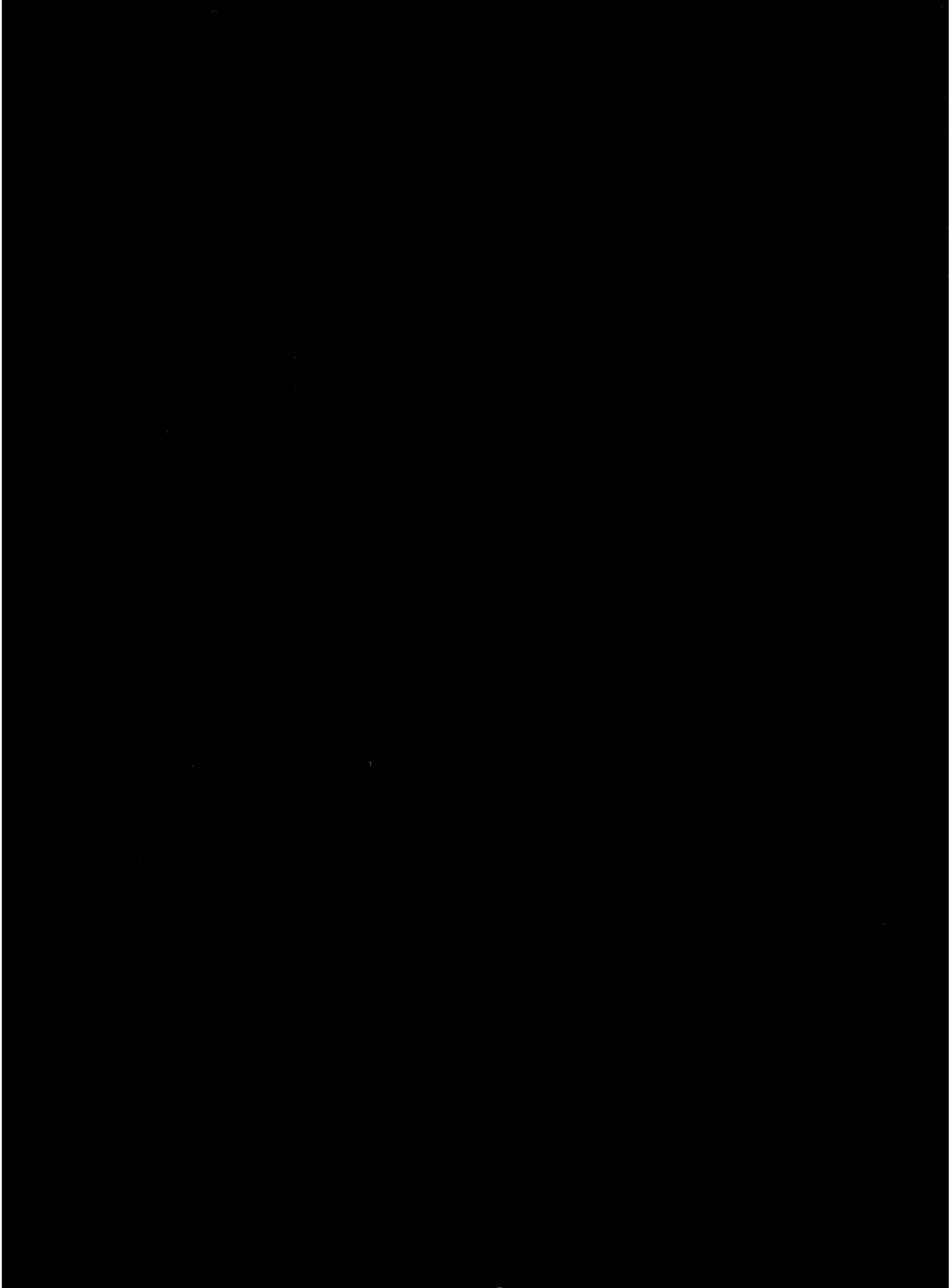

Draft for comments only — Not to be cited as East African Standard