



CD/K/140:2009
ICS 91.140.70

EAST AFRICAN STANDARD

Sanitary appliances — Crosslinked cast acrylic sheets for baths and shower trays for domestic purposes

Draft for comments only — Not to be cited as East African Standard

EAST AFRICAN COMMUNITY

Foreword

Development of the East African Standards has been necessitated by the need for harmonizing requirements governing quality of products and services in East Africa. It is envisaged that through harmonized standardization, trade barriers which are encountered when goods and services are exchanged within the Community will be removed.

In order to meet the above objectives, the EAC Partner States have enacted an East African Standardization, Quality Assurance, Metrology and Test Act, 2006 (EAC SQMT Act, 2006) to make provisions for ensuring standardization, quality assurance, metrology and testing of products produced or originating in a third country and traded in the Community in order to facilitate industrial development and trade as well as helping to protect the health and safety of society and the environment in the Community.

East African Standards are formulated in accordance with the procedures established by the East African Standards Committee. The East African Standards Committee is established under the provisions of Article 4 of the EAC SQMT Act, 2006. The Committee is composed of representatives of the National Standards Bodies in Partner States, together with the representatives from the private sectors and consumer organizations. Draft East African Standards are circulated to stakeholders through the National Standards Bodies in the Partner States. The comments received are discussed and incorporated before finalization of standards, in accordance with the procedures of the Community.

Article 15(1) of the EAC SQMT Act, 2006 provides that "Within six months of the declaration of an East African Standard, the Partner States shall adopt, without deviation from the approved text of the standard, the East African Standard as a national standard and withdraw any existing national standard with similar scope and purpose".

East African Standards are subject to review, to keep pace with technological advances. Users of the East African Standards are therefore expected to ensure that they always have the latest versions of the standards they are implementing.

© East African Community 2010 — All rights reserved*

East African Community

P O Box 1096

Arusha

Tanzania

Tel: 255 27 2504253/8

Fax: 255-27-2504481/2504255

E-Mail: eac@eachg.org

Web: www.each.int

Introduction

In the preparation of this East African Standard, the following source was consulted extensively:

BS EN 263:2008, *Sanitary appliances — Crosslinked cast acrylic sheets for baths and shower trays for domestic purposes*

Assistance derived from this source and others inadvertently not mentioned is hereby acknowledged.

Draft for comments only — Not to be cited as East African Standard

Sanitary appliances — Crosslinked cast acrylic sheets for baths and shower trays for domestic purposes

ICS 83.140.10; 91.140.70

National foreword

This British Standard is the UK implementation of EN 263:2008. It supersedes BS EN 263:2002 which is withdrawn.

The UK participation in its preparation was entrusted to Technical Committee B/503, Sanitary appliances.

A list of organizations represented on this committee can be obtained on request to its secretary.

This publication does not purport to include all the necessary provisions of a contract. Users are responsible for its correct application.

Compliance with a British Standard cannot confer immunity from legal obligations.

Licensed Copy: KEBB Information Resource Centre, Kenya Bureau of Standards, 15/01/2010 10:07, Uncontrolled Copy, (c) BSI

This British Standard was published under the authority of the Standards Policy and Strategy Committee on 31 March 2008

© BSI 2008

ISBN 978 0 580 57507 5

Amendments/corrigenda issued since publication

Date	Comments

English Version

Sanitary appliances - Crosslinked cast acrylic sheets for baths and shower trays for domestic purposes

Appareils sanitaires - Feuilles d'acrylique réticulées coulées
pour baignoires et receveurs de douche à usage
domestique

SanitärAusstattungsgegenstände - Vernetzte gegossene
Acrylplatten für Badewannen und Duschwannen für den
Hausgebrauch

This European Standard was approved by CEN on 12 January 2008.

CEN members are bound to comply with the CEN/CENELEC Internal Regulations which stipulate the conditions for giving this European Standard the status of a national standard without any alteration. Up-to-date lists and bibliographical references concerning such national standards may be obtained on application to the CEN Management Centre or to any CEN member.

This European Standard exists in three official versions (English, French, German). A version in any other language made by translation under the responsibility of a CEN member into its own language and notified to the CEN Management Centre has the same status as the official versions.

CEN members are the national standards bodies of Austria, Belgium, Bulgaria, Cyprus, Czech Republic, Denmark, Estonia, Finland, France, Germany, Greece, Hungary, Iceland, Ireland, Italy, Latvia, Lithuania, Luxembourg, Malta, Netherlands, Norway, Poland, Portugal, Romania, Slovakia, Slovenia, Spain, Sweden, Switzerland and United Kingdom.



EUROPEAN COMMITTEE FOR STANDARDIZATION
COMITÉ EUROPÉEN DE NORMALISATION
EUROPÄISCHES KOMITEE FÜR NORMUNG

Management Centre: rue de Stassart, 36 B-1050 Brussels

Contents

Page

Foreword.....	3
1 Scope	4
2 Normative references	4
3 Requirements	4
3.1 General requirements	4
3.2 Thickness	4
3.3 Heavy metal content	5
3.4 Colour	5
3.5 Thermal stability	5
3.6 Colour fastness	5
3.6.1 Resistance to UV light	5
3.6.2 Resistance to hot water	5
3.7 Resistance to chemicals and stains	5
3.8 Resistance to wet and dry cycling	5
4 Test methods	5
4.1 Determination of tensile strength	5
4.2 Determination of thermal stability	6
4.3 Determination of colour fastness to hot water	6
4.4 Determination of resistance to chemicals and stains	6
4.4.1 Reagents	6
4.4.2 Apparatus	6
4.4.3 Procedure	7
4.4.4 Results	8
4.5 Determination of resistance to wet and dry cycling	8
4.5.1 Test specimens	8
4.5.2 Procedure	8
4.5.3 Results	8
4.6 Verification of crosslinking	8
4.7 Determination of water absorption	8
4.7.1 Principle	8
4.7.2 Apparatus	9
4.7.3 Test specimens	9
4.7.4 General conditions	9
4.7.5 Procedure	9
4.7.6 Expression of results	9

Copy (c) BSI

Licensed Copy: KEBS Information Resource Centre, Kenya Bureau of Standards, 15/01/2010 10:07, Uncontrolled

Foreword

This document (EN 263:2008) has been prepared by Technical Committee CEN/TC 163 "Sanitary appliances", the secretariat of which is held by UNI.

This European Standard shall be given the status of a national standard, either by publication of an identical text or by endorsement, at the latest by August 2008, and conflicting national standards shall be withdrawn at the latest by August 2008.

Attention is drawn to the possibility that some of the elements of this document may be the subject of patent rights. CEN [and/or CENELEC] shall not be held responsible for identifying any or all such patent rights.

This document supersedes EN 263:2002.

The performance criteria for baths and shower trays for domestic purposes made from crosslinked cast acrylic sheets are divided into two European Standards as follows:

prEN 198 Sanitary appliances - *Baths made from crosslinked cast acrylic sheets - Requirements and test methods.*

prEN 249 Sanitary appliances - *Shower trays made from crosslinked cast acrylic sheets - Requirements and test methods.*

This revised version of EN 263 includes the following amendments, compared to the version of 2002:

- Deletion of reference to ISO 62 standard for water absorption test and replacement with the description of the test itself.
- Modification of eosine concentration in resistance to chemical and stains test.

According to the CEN/CENELEC Internal Regulations, the national standards organizations of the following countries are bound to implement this European Standard: Austria, Belgium, Bulgaria, Cyprus, Czech Republic, Denmark, Estonia, Finland, France, Germany, Greece, Hungary, Iceland, Ireland, Italy, Latvia, Lithuania, Luxembourg, Malta, Netherlands, Norway, Poland, Portugal, Romania, Slovakia, Slovenia, Spain, Sweden, Switzerland and the United Kingdom.

1 Scope

This European Standard specifies requirements and test methods for cross-linked cast acrylic sheets (called acrylic sheets hereafter) from which baths and shower trays for domestic purposes are manufactured.

NOTE For the purposes of this standard, the term "domestic purposes" includes use in hotels, accommodation for students, hospitals and similar buildings, except when special medical provisions are required.

2 Normative references

The following referenced documents are indispensable for the application of this document. For dated references, only the edition cited applies. For undated references, the latest edition of the referenced document (including any amendments) applies.

EN 20105-A02, *Textiles - Tests for colour fastness - Part A02: Grey scale for assessing change in colour (ISO 105-A02:1993)*

EN ISO 306, *Plastics - Thermoplastic materials - Determination of Vicat softening temperature (VST) (ISO 306:2004)*

EN ISO 527-2, *Plastics - Determination of tensile properties - Part 2: Test conditions for moulding and extrusion plastics (ISO 527-2:1993 including Corr 1:1994)*

EN ISO 4892-2, *Plastics - Methods of exposure to laboratory light sources - Part 2: Xenon-arc lamps (ISO 4892-2:2006)*

3 Requirements

3.1 General requirements

The acrylic sheet shall comply with the requirements given in Table 1.

Table 1 - General requirements

Property	Test method	Requirement
Vicat softening point	EN ISO 306 ¹⁾	≥ 105°C
Water absorption	4.7 of this standard	≤ 40 mg
Tensile strength	EN ISO 527-2 and 4.1 of this standard	≥ 60 MPa
Cross-linking	4.6 of this standard	no sign of dissolving or sticking

1) Method B 50, temperature raised at a rate of (50 ± 5)°C/h.

3.2 Thickness

The thickness of the acrylic sheet shall be not less than 2,7 mm. The maximum tolerance on thickness Δh shall be $\pm (0,4 + 0,1h)$, h being the nominal sheet thickness in mm.

3.3 Heavy metal content

Heavy metal contents of crosslinked cast acrylic sheets for baths and shower trays should be lower than those defined in the European Directive 91/338/EEC.

3.4 Colour

The acrylic sheets shall be transparent or coloured. In the case of coloured sheet, the colourant shall be incorporated during the manufacture of the sheet and the colour shall be throughout the thickness of the material.

3.5 Thermal stability

When tested by the method given in 4.2, the acrylic sheet shall show no evidence of blistering.

3.6 Colour fastness

3.6.1 Resistance to UV light

When tested according to EN ISO 4892-2 with an irradiance of 0,5 GJ/m² in the wavelength range of 290 nm to 800 nm, the colour change noted in the acrylic sheet shall be recorded in terms of the grey scale for assessing colour change specified in EN 20105-A02. The fastness rating shall be not less than grade 3.

3.6.2 Resistance to hot water

When tested in accordance with 4.3, the colour change noted in the acrylic sheet shall be recorded in terms of the grey scale for assessing colour change specified in EN 20105-A02. The fastness rating shall be not less than grade 3.

3.7 Resistance to chemicals and stains

When tested in accordance with 4.4, the acrylic sheet shall show no permanent staining or deterioration.

3.8 Resistance to wet and dry cycling

When tested in accordance with 4.5, the acrylic sheet shall not show any adverse changes in appearance such as blisters, crazes, cracks and discoloration.

4 Test methods

4.1 Determination of tensile strength

The test specimen shall be of type 1B according to EN ISO 527-2. The thickness of the test specimen shall be that of the sheet from which it is cut.

The test shall be carried out at a temperature of $(23 \pm 2)^\circ\text{C}$ and the test specimens shall be conditioned to this temperature for at least two days before testing.

The speed of testing shall be (5 ± 1) mm/min.

The mean of five determinations shall be recorded as the tensile strength of the material but if a test specimen breaks in the grips the result shall be disregarded and a further determination made. The tensile strength shall be calculated by dividing the breaking load by the cross-sectional area of the specimen before testing.

4.2 Determination of thermal stability

Hang two sheets 300 mm square, taken from the acrylic sheet, in a circulating oven at $(200 \pm 5)^\circ\text{C}$ for 20 min when this nominal temperature is reached. Remove the sheets from the oven, allow them to cool to room temperature while hanging vertically and visually examine them for the presence of blisters. If blistering occurs, repeat the test using two new specimens which have been preconditioned at $(80 \pm 2)^\circ\text{C}$ for 16 h.

4.3 Determination of colour fastness to hot water

Cut a test specimen 100 mm x 25 mm from the acrylic sheet and fix in a suitable carrier. Immerse the test specimen in a water bath maintained at $(60 \pm 2)^\circ\text{C}$ for 30 min, remove and allow to drain and dry in air for 30 min.

Repeat the cycle one hundred times without interruption.

Allow 48 h for the test specimen to dry out before it is compared with a sample of the sheet from which it was cut.

The colour fastness of the material shall be recorded in terms of the grey scale for assessing colour change specified in EN 20105-A02.

4.4 Determination of resistance to chemicals and stains

4.4.1 Reagents

The list of reagents is given in Table 2. Each aqueous solution shall be prepared immediately before application. The reagents shall be made up and applied at $(23 \pm 5)^\circ\text{C}$.

Table 2 - Reagents

Family	Product	Concentration
Acids	Acetic acid	Volume fraction of 10%
Alkalis	NaOH	Mass fraction of 10%
Alcohol	Ethanol	Volume fraction of 70%
Bleaches	NaOCl	5% available chlorine
Staining agent	Methylene Blue	Mass fraction of 1%

4.4.2 Apparatus

4.4.2.1 Borosilicate watch glasses

40 mm nominal diameter

4.4.2.2 Pipettes

4.4.2.3 Cleaning device

This is shown in Figure 1. It comprises a synthetic flexible open cell foam disc of 75 mm diameter and 15 mm thick. Use any rotating device applying a mass of $(1\,000 \pm 50)$ g which loosely fits with the device. The lateral cleaning force shall only be that exerted by the mass of the cleaning device; this can be affected by a floating action between the drive shaft and the disc.

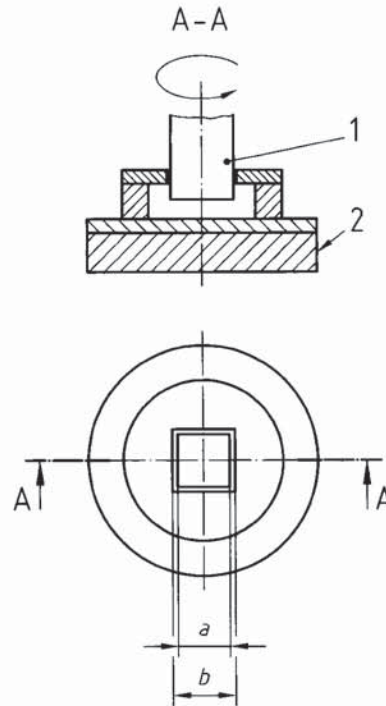

Key

- 1 square axle, $a = b - 1$ mm
- 2 foam
- a inner dimension
- b outer dimension

Figure 1 - Detail of cleaning apparatus

4.4.2.4 Test specimens

Specimens shall measure (100 ± 5) mm x (100 ± 5) mm.

4.4.3 Procedure

Use a separate test specimen for each reagent test. Clean the test area thoroughly with hot soapy water, rinse and dry with a clean soft cloth.

On each test specimen deposit a drop of the test solution. Cover the drop thus formed with a watch glass concave downwards. The drop size shall be determined in order to be completely covered by the watch glass. Allow to act for a time of (120 ± 5) min, at a temperature of $(23 \pm 5)^{\circ}\text{C}$ with the test areas protected from the affects of sunlight.

Thoroughly rinse the test specimen with demineralized water and check for adverse changes in appearance by visual examination. If deterioration exists, dip the foam disc of the cleaning device into demineralized water and place it on the surface to be cleaned. Rotate the device at 60 min^{-1} .

Clean for thirty revolutions.

Rinse with demineralized water and visually examine the test area. If deterioration persists repeat the cleaning process with an abrasive agent added to demineralized water. This abrasive agent is defined as follows: alumina used for surface polishing, with particle size comprised between $0,1 \mu\text{m}$ and $2 \mu\text{m}$ and centred on $0,5 \mu\text{m}$.

4.4.4 Results

Note whether or not the reagent causes a stain or deterioration, whether or not such stain or deterioration is removed and if so with water or water with abrasive agent. If the stain is not removed by the water with abrasive agent record as permanently stained.

4.5 Determination of resistance to wet and dry cycling

4.5.1 Test specimens

The specimens to be tested shall be (100 ± 2) mm². Prior to commencing the test examine the show faces of the samples and mark any surface defects.

4.5.2 Procedure

Place a maximum of ten specimens to be tested vertically in a suitable carrier and place the carrier in a suitable open container. The carrier shall be arranged to avoid contact of one test specimen with another.

Pour 2 l of boiling water into the container. Test specimens must be covered.

Leave the test specimens in the water for $(8 \pm 0,25)$ h whilst allowing cooling to room temperature.

Remove the test specimens from the water, wipe the surfaces with a soft dampened cloth and place the test specimens for drying into an oven for $(16 \pm 0,5)$ h at a temperature of (50 ± 2) °C. When placing the test specimens in the oven ensure they do not touch the oven walls or each other.

Repeat this cycle twenty times using the same test specimens. In the event of an interruption of the test procedure, e.g. over the weekend, leave the test specimens in the oven at a temperature of (50 ± 2) °C.

After twenty cycles brush over the show face of each test specimen with a solution of eosine (100 g/l in water) to which is added 1 cm³/l of liquid detergent using a soft sponge or a paint brush. Leave the solution for (5 ± 1) min, then remove from the surface by wiping with a clean soft dampened cloth.

4.5.3 Results

Verify and record any adverse changes in appearance (blisters, crazing, cracks etc.) by visual examination and by the presence of traces of eosine.

When making the visual inspection, ignore the 3 mm width along each side to exclude any influence caused by the cut edges.

4.6 Verification of crosslinking

Cut a sample approximately (30 ± 5) mm x (20 ± 5) mm from the sheet under test. Place this in a sealed glass container with 100 ml of methyl-methacrylate or chloroform. Leave for at least 16 h (methyl methacrylate) or 2 h (chloroform) at (23 ± 5) °C. After immersion check if the specimen is dissolved or sticks to the walls of the container. When touched with a glass rod or a spatula, check if the sample sticks to it or shows signs of stringing as the rod or spatula is removed.

4.7 Determination of water absorption

4.7.1 Principle

Complete immersion of test specimens in water for a specified period of time and at a specified temperature. Determination of changes in the mass of the test specimens after immersion in water.

m_2 is the mass, in milligrams, of the test specimen after immersion.

Express the result as the arithmetic mean of the three values of m obtained.

BSI — British Standards Institution

BSI is the independent national body responsible for preparing British Standards. It presents the UK view on standards in Europe and at the international level. It is incorporated by Royal Charter.

Revisions

British Standards are updated by amendment or revision. Users of British Standards should make sure that they possess the latest amendments or editions.

It is the constant aim of BSI to improve the quality of our products and services. We would be grateful if anyone finding an inaccuracy or ambiguity while using this British Standard would inform the Secretary of the technical committee responsible, the identity of which can be found on the inside front cover. Tel: +44 (0)20 8996 9000. Fax: +44 (0)20 8996 7400.

BSI offers members an individual updating service called PLUS which ensures that subscribers automatically receive the latest editions of standards.

Buying standards

Orders for all BSI, international and foreign standards publications should be addressed to Customer Services. Tel: +44 (0)20 8996 9001. Fax: +44 (0)20 8996 7001. Email: orders@bsi-global.com. Standards are also available from the BSI website at <http://www.bsi-global.com>.

In response to orders for international standards, it is BSI policy to supply the BSI implementation of those that have been published as British Standards, unless otherwise requested.

Information on standards

BSI provides a wide range of information on national, European and international standards through its Library and its Technical Help to Exporters Service. Various BSI electronic information services are also available which give details on all its products and services. Contact the Information Centre. Tel: +44 (0)20 8996 7111. Fax: +44 (0)20 8996 7048. Email: info@bsi-global.com.

Subscribing members of BSI are kept up to date with standards developments and receive substantial discounts on the purchase price of standards. For details of these and other benefits contact Membership Administration. Tel: +44 (0)20 8996 7002. Fax: +44 (0)20 8996 7001. Email: membership@bsi-global.com.

Information regarding online access to British Standards via British Standards Online can be found at <http://www.bsi-global.com/bsonline>.

Further information about BSI is available on the BSI website at <http://www.bsi-global.com>.

Copyright

Copyright subsists in all BSI publications. BSI also holds the copyright, in the UK, of the publications of the international standardization bodies. Except as permitted under the Copyright, Designs and Patents Act 1988 no extract may be reproduced, stored in a retrieval system or transmitted in any form or by any means – electronic, photocopying, recording or otherwise – without prior written permission from BSI.

This does not preclude the free use, in the course of implementing the standard, of necessary details such as symbols, and size, type or grade designations. If these details are to be used for any other purpose than implementation then the prior written permission of BSI must be obtained.

Details and advice can be obtained from the Copyright & Licensing Manager. Tel: +44 (0)20 8996 7070. Fax: +44 (0)20 8996 7553. Email: copyright@bsi-global.com.

BSI
389 Chiswick High Road
London
W4 4AL

Draft for comments only — Not to be cited as East African Standard