



CD/K/128:2009
ICS 91.140.80; 91.100.40

EAST AFRICAN STANDARD

Fibre-reinforced cement pipe, joints and fittings for gravity systems

EAST AFRICAN COMMUNITY

Foreword

Development of the East African Standards has been necessitated by the need for harmonizing requirements governing quality of products and services in East Africa. It is envisaged that through harmonized standardization, trade barriers which are encountered when goods and services are exchanged within the Community will be removed.

In order to meet the above objectives, the EAC Partner States have enacted an East African Standardization, Quality Assurance, Metrology and Test Act, 2006 (EAC SQMT Act, 2006) to make provisions for ensuring standardization, quality assurance, metrology and testing of products produced or originating in a third country and traded in the Community in order to facilitate industrial development and trade as well as helping to protect the health and safety of society and the environment in the Community.

East African Standards are formulated in accordance with the procedures established by the East African Standards Committee. The East African Standards Committee is established under the provisions of Article 4 of the EAC SQMT Act, 2006. The Committee is composed of representatives of the National Standards Bodies in Partner States, together with the representatives from the private sectors and consumer organizations. Draft East African Standards are circulated to stakeholders through the National Standards Bodies in the Partner States. The comments received are discussed and incorporated before finalization of standards, in accordance with the procedures of the Community.

Article 15(1) of the EAC SQMT Act, 2006 provides that "Within six months of the declaration of an East African Standard, the Partner States shall adopt, without deviation from the approved text of the standard, the East African Standard as a national standard and withdraw any existing national standard with similar scope and purpose".

East African Standards are subject to review, to keep pace with technological advances. Users of the East African Standards are therefore expected to ensure that they always have the latest versions of the standards they are implementing.

© East African Community 2010 — All rights reserved*

East African Community

P O Box 1096

Arusha

Tanzania

Tel: 255 27 2504253/8

Fax: 255-27-2504481/2504255

E-Mail: eac@eachq.org

Web: www.each.int

* © 2010 EAC — All rights of exploitation in any form and by any means reserved worldwide for EAC Partner States' NSBs.

Introduction

In the preparation of this East African Standard, the following source was consulted extensively:

ISO 22306:2007, *Fibre-reinforced cement pipe, joints and fittings for gravity systems*

Assistance derived from this source and others inadvertently not mentioned is hereby acknowledged.

Draft for comments only — Not to be cited as East African Standard

Fibre-reinforced cement pipe, joints and fittings for gravity systems

Tuyaux, joints et accessoires en ciment renforcé de fibres pour réseaux gravitaires

Draft for comments only — Not to be cited as East African Standard



PDF disclaimer

This PDF file may contain embedded typefaces. In accordance with Adobe's licensing policy, this file may be printed or viewed but shall not be edited unless the typefaces which are embedded are licensed to and installed on the computer performing the editing. In downloading this file, parties accept therein the responsibility of not infringing Adobe's licensing policy. The ISO Central Secretariat accepts no liability in this area.

Adobe is a trademark of Adobe Systems Incorporated.

Details of the software products used to create this PDF file can be found in the General Info relative to the file; the PDF-creation parameters were optimized for printing. Every care has been taken to ensure that the file is suitable for use by ISO member bodies. In the unlikely event that a problem relating to it is found, please inform the Central Secretariat at the address given below.



COPYRIGHT PROTECTED DOCUMENT

© ISO 2007

All rights reserved. Unless otherwise specified, no part of this publication may be reproduced or utilized in any form or by any means, electronic or mechanical, including photocopying and microfilm, without permission in writing from either ISO at the address below or ISO's member body in the country of the requester.

ISO copyright office
Case postale 56 • CH-1211 Geneva 20
Tel. + 41 22 749 01 11
Fax + 41 22 749 09 47
E-mail copyright@iso.org
Web www.iso.org

Published in Switzerland

Contents

	Page
Foreword.....	iv
1 Scope	1
2 Normative references	1
3 Terms and definitions.....	1
4 General.....	5
4.1 Classification.....	5
4.2 Materials	5
4.3 Appearance and finish	6
4.4 Joints.....	7
4.5 Reference conditions for testing.....	7
5 Pipes.....	8
5.1 Geometrical characteristics.....	8
5.2 Mechanical characteristics	10
5.3 Resistance to domestic sewage.....	13
5.4 Warm water test	14
5.5 Marking of pipes	14
6 Joints.....	15
6.1 General requirements.....	15
6.2 Joint geometrical requirements	15
6.3 Joint hydrostatic performance	15
6.4 Marking of joints and fittings.....	16
7 Handling and storage	16
Annex A (normative) Test method for determination of pipe straightness	17
Annex B (normative) Test method for determination of pipe crush strength.....	19
Annex C (normative) Test method for determination of pipe flexural bending strength.....	23
Annex D (normative) Test method for determination of watertightness	25
Annex E (normative) Test method for determination of the modulus of elasticity	27
Annex F (normative) Test method for determination of the long-term pipe stiffness	31
Annex G (normative) Method of determination of resistance to liquid media.....	35
Annex H (normative) Test method for determination of joint performance under hydrostatic pressure	37
Annex I (informative) Test method for determination of wet/dry crush factor.....	41
Annex J (informative) Installation design of fibre-reinforced cement pipes	43
Bibliography.....	47

Foreword

ISO (the International Organization for Standardization) is a worldwide federation of national standards bodies (ISO member bodies). The work of preparing International Standards is normally carried out through ISO technical committees. Each member body interested in a subject for which a technical committee has been established has the right to be represented on that committee. International organizations, governmental and non-governmental, in liaison with ISO, also take part in the work. ISO collaborates closely with the International Electrotechnical Commission (IEC) on all matters of electrotechnical standardization.

International Standards are drafted in accordance with the rules given in the ISO/IEC Directives, Part 2.

The main task of technical committees is to prepare International Standards. Draft International Standards adopted by the technical committees are circulated to the member bodies for voting. Publication as an International Standard requires approval by at least 75 % of the member bodies casting a vote.

Attention is drawn to the possibility that some of the elements of this document may be the subject of patent rights. ISO shall not be held responsible for identifying any or all such patent rights.

ISO 22306 was prepared by Technical Committee ISO/TC 77, *Products in fibre reinforced cement*.

Fibre-reinforced cement pipe, joints and fittings for gravity systems

1 Scope

This International Standard specifies the properties of the piping system and its components made from fibre-reinforced cement, based upon Portland cement, intended to be used for drainage or sewerage systems. This International Standard is applicable to fibre-reinforced cement pipes and fittings suitable primarily for use in gravity systems at atmospheric pressure in buried applications.

Pipes satisfying the requirements of this International Standard, although exhibiting some flexible characteristics, are intended for installations designed using rigid pipe principles.

NOTE 1 In a pipe work system, pipes and fittings of different strength classification can be used together.

NOTE 2 Piping systems conforming to this International Standard can be used also for non-buried applications provided the influences of the environment and the supports are considered in the design of the pipes, fittings and joints.

NOTE 3 This International Standard addresses aspects of long-term performance of pipe (see Annex J).

NOTE 4 Purchasers should satisfy themselves that the class of pipe specified on the basis of this International Standard is suitable for its intended application.

NOTE 5 Compliance with Annex G of this International Standard might not satisfy national regulatory requirements.

2 Normative references

The following referenced documents are indispensable for the application of this document. For dated references, only the edition cited applies. For undated references, the latest edition of the referenced document (including any amendments) applies.

ISO 10928, *Plastics piping systems — Glass-reinforced thermosetting plastics (GRP) pipes and fittings — Methods for regression analysis and their use*

3 Terms and definitions

For the purposes of this document, the following terms and definitions apply.

3.1

nominal size

DN

alphanumerical designation of size, which is common to all components in a piping system, in order to provide a convenient designation for reference and marking purposes, consisting of the letters “DN” followed by a round number related to the internal diameter when it is expressed in millimetres

**3.2
declared diameter**

diameter which a manufacturer states to be the mean internal or external diameter produced in respect of a particular nominal size DN and crushing strength class

**3.3
specific ring stiffness**

S
calculated physical characteristic of the pipe, indicating the resistance to ring deflection per metre length under external load as defined in Equation (1):

$$S = (E \cdot I) / d_m^3 \quad (1)$$

where

E is the apparent modulus of elasticity as determined using Annex E of this International Standard, expressed in newtons per square metre (N/m²)

I is the second moment of area in the longitudinal direction per metre length, expressed in metres to the fourth power per metre, (m⁴/m), i.e.

$$I = e^3 / 12 \quad (2)$$

where

e is the wall thickness, expressed in metres (m)

d_m is the mean diameter of the pipe, expressed in metres (m) (see 3.4)

NOTE The specific ring stiffness is expressed in newtons per square metre (N/m²).

**3.4
mean diameter**

d_m
diameter of the circle corresponding with the middle of the pipe wall cross-section calculated by either Equation (3) or (4):

$$d_m = d_i + e \quad (3)$$

$$d_m = d_e - e \quad (4)$$

where

d_i is the internal diameter of the pipe in metres (m)

d_e is the external diameter of the pipe in metres (m)

e is the wall thickness of the pipe, in metres (m)

NOTE The mean diameter is expressed in metres (m).

**3.5
type test**

test carried out in order to assess the fitness for purpose of a product or assembly of components to fulfil its or their function(s) in accordance with the product specification

3.6**nominal length**

numerical designation of a pipe length which is equal to the pipe's effective laying length (see 3.8)

NOTE The nominal length is expressed in metres (m), rounded to one decimal place.

3.7**total length**

L

distance between two planes normal to the pipe axis and passing through the extreme end points of the pipe

NOTE The total length is expressed in metres (m).

3.8**effective laying length**

total length of a pipe minus, where applicable, the insertion depth of the spigot(s) in the socket as recommended by the manufacturer

3.9**normal service conditions**

conveyance of surface water or sewage in the temperature range 2 °C to 50 °C, with or without pressure

3.10**crush load**

T_u

minimum crush test load required for a saturated pipe, when tested according to Annex B to demonstrate that it complies with its designated crush class

3.11**non-pressure pipe or fitting**

pipe [fitting] subject to an internal pressure not greater than 100 kPa

3.12**buried pipeline**

pipeline that is subjected to the external pressure transmitted from soil loading, including traffic and superimposed loads and, possibly, the pressure head of water

3.13**design service temperature**

maximum sustained temperature at which the system is expected to operate

NOTE The design service temperature is expressed in degrees Celsius (°C).

3.14**draw**

D

longitudinal movement of a joint

See Figure 1.

NOTE The draw is expressed in millimetres (mm).

3.15**total draw**

T

sum of the draw, D , and the additional longitudinal movement, J , of joint components due to the presence of angular deflection

See Figure 1.

NOTE The total draw is expressed in millimetres (mm).

**3.16
misalignment**

M
amount by which the centrelines of adjacent components fail to coincide

See Figure 1.

NOTE The misalignment is expressed in millimetres (mm).

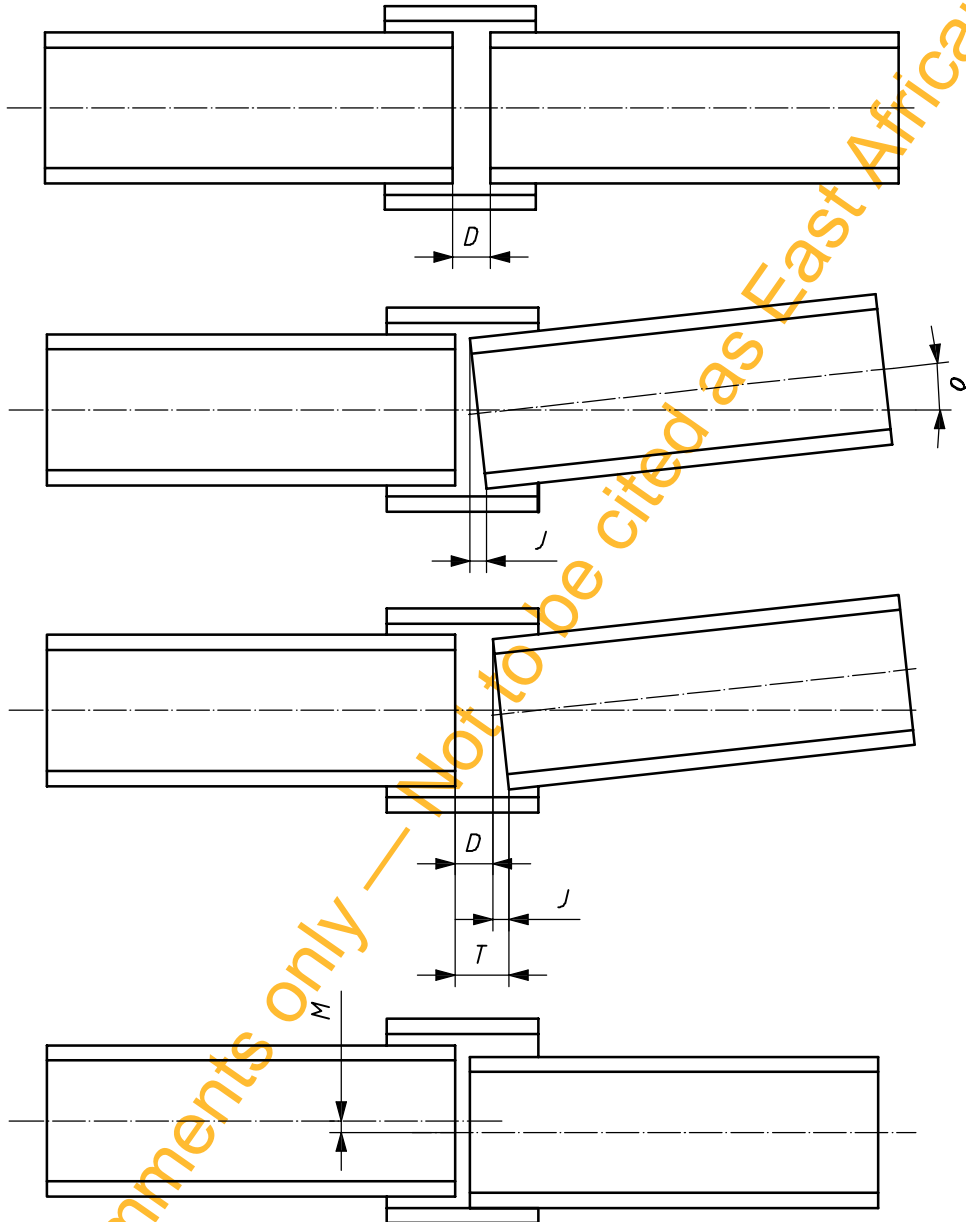

Key

- D* draw
- δ angular deflection
- J* longitudinal movement
- T* total draw
- M* misalignment

NOTE The angular deflection causes a longitudinal movement.

Figure 1 — Joint movements

3.17**flexible joint**

joint that allows relative movement between components being joined

3.18**break**

condition when the test piece can no longer carry load

3.19**reinforcement fibre**

organic and/or inorganic synthetic reinforcement fibres used for the manufacture of fibre cement pipes complying with this International Standard

See 4.2.2.

4 General**4.1 Classification****4.1.1 Categories**

Pipes and fittings shall be classified according to nominal size (DN) (see 3.1), design crush strength and joint type.

4.1.2 Nominal size

The nominal size (DN) of pipes and fittings in the range DN 200 to DN 2500 shall conform to the appropriate table in Clause 5 of this International Standard.

4.1.3 Crushing strength (T_U)

The pipes shall be classified in accordance with their minimum crush load, T_U , into the following classes based on load per unit internal area:

40 kN/m², 60 kN/m², 75 kN/m², 90 kN/m², 100 kN/m², 120 kN/m², 150 kN/m², 175 kN/m²

The load per unit area is the breaking load per metre length of pipe divided by the nominal diameter of the pipe in metres (1/1 000 of the nominal diameter DN values).

Pipes may also be designed to satisfy breaking load requirements that are specified either by the designer or in the national standards of the country where the product is to be used.

4.2 Materials**4.2.1 General**

The pipe or fitting shall be constructed using reinforcing fibres (see 3.19) and an inorganic hydraulic binder or a calcium silicate binder formed by chemical reaction of a siliceous and a calcareous material.

Process aids, fillers, aggregates and pigments that are compatible with fibre-reinforced cement may be added.

4.2.2 Reinforcement

Reinforcement may be any of the following:

- a) cellulose fibre;
- b) plastic fibre;

- c) glass filament;
- d) steel fibre.

No further restriction is placed on the choice of fibre-reinforcement materials, their combination, their proportion in the finished product, or the method of pipe manufacture, except that pipes manufactured using these materials shall comply with the requirements of this International Standard. The manufacturer shall provide the purchaser with documented evidence that the fibres employed are compatible with the other materials in the pipes for the intended purpose of the pipes under normal service conditions (see 3.9).

4.2.3 Cement

The cement shall comply with the relevant national standard in the country of manufacture.

4.2.4 Aggregates and fillers

Where aggregates or fillers are added to the mix in the manufacturing process, the filler shall be inorganic and shall be compatible with other materials in the mix to ensure the long-term performance durability.

Lightweight aggregate and non-ferrous metallurgical slag shall not be used in pipes and fittings.

4.2.5 Restriction on chemical content

The materials shall not contain acid-soluble chloride or sulfate salts in excess of the values given in Table 1.

Table 1 — Maximum values of acid-soluble chloride ion and sulfate ion content in cement as cast

Condition	Maximum acid-soluble chloride ion content kg/m ³	Maximum acid-soluble sulfate ion content % (by mass of cement)
Cement cured other than by steam or autoclaving	0,8	5,0
Steam-cured and autoclaved cement	0,8	4,0

4.3 Appearance and finish

Both internal and external surfaces shall be free from irregularities which would impair the ability of the component to conform to the requirements of this International Standard.

The internal surface of the pipe shall be regular and smooth. The surfaces that are in contact with elastomeric seals shall be free of irregularities that can affect the performance of the joints.

Pipes shall be free from fractures and cracks wider than 0,1 mm and deeper than 0,3 mm (see ISO 3126^[1]). Pipes shall be free from delamination. Dents on either the inside or outside surfaces shall not exceed 3 mm in depth and bulges shall not exceed 3 mm in height. Dents and bulges shall not extend laterally in any direction on a surface by more than 50 mm.

If necessary, pipes may be impregnated and/or coated internally and/or externally to meet special working conditions as agreed between manufacturer and purchaser. The coating and finish should satisfy the requirements of national standards, if existing.

4.4 Joints

4.4.1 General

If requested, the manufacturer shall declare the length and the maximum external diameter of the assembled joint.

4.4.2 Types of joints

The joints for fibre-reinforced cement pipes and fittings covered by this International Standard shall be spigot and sockets or sleeves.

4.4.3 Materials

Spigot and sockets joints and sleeves may be formed in fibre-reinforced cement using the same production process as the pipes or, alternatively, they may be made of other materials such as plastics or metal, providing that they comply with the relevant International Standard or national standard, if existing. All materials shall be specified by the pipe manufacturer.

4.4.4 Sealing rings

Sealing rings shall be of an elastomeric material, suitable for use with the liquid being conveyed. The elastomeric material(s) of the sealing component shall conform to the applicable national standard.

4.4.5 Allowable angular deflection

The manufacturer shall declare the maximum allowable angular deflection for which each joint is designed.

4.4.6 Maximum draw

The manufacturer shall declare the maximum draw for which the joint is designed.

4.5 Reference conditions for testing

4.5.1 Temperature

The mechanical, physical and chemical properties specified in all clauses of this International Standard shall, unless otherwise specified, be determined at (23 ± 5) °C.

4.5.2 Properties of water for testing

The water used for tests referred to in this International Standard shall be tap water having a pH of 7 ± 2 .

4.5.3 Loading conditions

Unless otherwise specified, the mechanical, physical and chemical properties specified in all clauses of this International Standard shall be determined using circumferential and/or longitudinal loading conditions, as applicable.

4.5.4 Measurement of dimensions

In case of dispute, the dimensions of components shall be determined at the temperature specified in 4.5.1. Measurements shall be made in accordance with ISO 3126^[1] or otherwise using any method of sufficient accuracy to determine conformity, or otherwise, to the applicable limits. Routine measurements shall be determined at the prevailing temperature or, if the manufacturer prefers, at the temperature specified in 4.5.1.

5 Pipes

5.1 Geometrical characteristics

5.1.1 Diameter

5.1.1.1 Diameter series

Pipes shall be designated by nominal size in accordance with Table 2. Nominal diameters without brackets are preferred sizes.

Table 2 — Specified pipe internal diameters

Nominal size DN mm	Nominal size DN mm
100	(900)
125	1 000
150	(1 050)
200	(1 100)
(225)	1 200
250	(1 300)
300	1 400
(350)	(1 500)
(375)	1 600
400	(1 700)
(450)	1 800
500	(1 900)
(525)	2 000
600	(2 100)
(675)	2 200
(700)	(2 300)
(750)	(2 400)
800	2 500
(825)	

5.1.1.2 Internal diameter

The mean internal diameter, d_i , shall be declared by the manufacturer and, when measured, it shall be within the tolerance limits given below:

$$d_i \leq 300 \quad \pm 5 \text{ mm}$$

$$300 < d_i \leq 600 \quad \pm 7 \text{ mm}$$

$$600 < d_i \leq 1\,200 \quad \pm 8 \text{ mm}$$

$$1\,200 < d_i \leq 1\,650 \quad \pm 10 \text{ mm}$$

$$1\,650 < d_i \quad \pm 13 \text{ mm}$$

The mean internal diameter, d_i , may be determined by taking two measurements mutually at right angles at 200 mm from each end. The mean internal diameter shall be taken as the mean of the four values.

Alternatively, the mean internal diameter may be determined by measuring the average external diameter with a diameter tape and subtracting the mean of four measurements of wall thickness taken at equal intervals around the circumference.

5.1.1.3 External diameter

The external diameter d_e of the plain pipe or machined end of the pipe when measured in millimetres, shall comply with the value stated in the manufacturer's literature.

5.1.2 Thickness of wall

The wall thickness, e , expressed in millimetres, excluding the machined end, shall be determined by direct measurement and shall not vary from the value stated in the manufacturer's literature by more than $0,1e$ mm.

5.1.3 Length

5.1.3.1 Nominal length of pipes

The nominal length, L (see 3.6), measured in metres, shall be one of the following values:

2,0; 2,5; 3,0; 4,0; 5,0; or 6,0

NOTE Pipes of nominal length of 5,0 and 6,0 apply only to sizes greater than DN 200.

Other lengths may be supplied as agreed between the manufacturer and purchaser.

5.1.3.2 Effective laying length

The pipe shall be supplied in effective laying lengths (see 3.8) in accordance with the requirements given in the following paragraph.

Of the total number of pipes supplied in each diameter, the manufacturer may supply up to 10 % in lengths shorter than the nominal length unless a higher percentage of pipes is being supplied by agreement between the manufacturer and purchaser. The tolerance of the manufacturer's nominated effective lengths shall be ± 15 mm.

5.1.4 Straightness

When tested in accordance with the test method given in Annex A, the deviation on straightness, f , of a full length of pipe, L , shall not exceed the values given in Table 3.

Table 3 — Maximum straightness deviation

DN	Maximum deviation f mm
100 to 150	$3,0 L$
200 to 1 000	$2,5 L$
1 100 to 2 500	$1,5 L$

5.2 Mechanical characteristics

5.2.1 Crush Strength

5.2.1.1 General

When tested to determine the initial crush break load, T_u , in the saturated condition, according to the test method given in Annex B, the minimum initial crush break values for pipes in the diameter range DN 100 to DN 1 000 shall not be less than those given in Table 4.

The minimum initial crush break load, T_u , expressed in kilonewtons per metre, for pipe having a nominal diameter DN greater than 1 000 is determined using Equation (5):

$$T_u = C \cdot DN \cdot 10^{-3} \tag{5}$$

where

C pipe class, expressed in kilonewtons per metre;

DN pipe nominal diameter, expressed in millimetres.

When sampling from continuous production, crush tests may also be conducted on dry, equilibrium or wet specimens, provided a relationship can be established between this testing and the specified fully saturated minimum break load values. A method for determining such a relationship is given in Annex I. The relationship between the initial saturated crush load, T_u , to the installation design load is dependent upon the long-term install behaviour of the pipe (see Annex J).

Table 4 — Minimum initial crush break load, T_u , per metre length for fully saturated pipe

Values in kilonewtons per metre

DN	Class 40	Class 60	Class 75	Class 90	Class 100	Class 120	Class 150	Class 175
100	—	—	—	—	—	20 ^a	25 ^a	29 ^a
125	—	—	—	—	—	21 ^a	26,5 ^a	30,5 ^a
150	—	—	—	—	—	22 ^a	27,5 ^a	32 ^a
200	15 ^a	15 ^a	15	18	20	24	30	35
250	15 ^a	15	19	22,5	25	30	37,5	44
300	15 ^a	18	22,5	27	30	36	45	52,5
350	15 ^a	21	26,5	31,5	35	42	52,5	61,5
400	16	24	30	36	40	48	60	70
450	18	27	34	40,5	45	54	67,5	79
500	20	30	37,5	45	50	60	75	87,5
600	24	36	45	54	60	72	90	105
700	28	42	52,5	63	70	84	105	122,5
800	32	48	60	72	80	96	120	140
900	38	54	67,5	81	90	108	135	157,5
1 000	40	60	75	90	100	120	150	175

^a Minimum breaking loads exceed the calculated minimum requirement to satisfy other design criteria.

5.2.1.2 Number of test pieces for type test purposes

Two test pieces, of the same size and classification and conforming to 5.2.1.3 shall be used.

5.2.1.3 Length of test pieces

The minimum length, L_p , of the test piece shall be 150 ± 5 mm.

5.2.1.4 Conditioning of test piece

- Specimens that are to be tested in a saturated condition shall be immersed in water at an ambient temperature above 5°C for a period of at least 28 days, immediately prior to testing.
- Specimens which are to be tested in a dry condition shall be stored in air at a temperature of $23 \pm 5^\circ\text{C}$ and at $50 \pm 10\%$ RH for 7^{+1}_0 days, immediately prior to testing.

Other conditioning methods that can be shown to give the same sample strength and steady state are acceptable. In the event of a dispute, the requirements of 5.2.1.4 a) shall apply.

5.2.1.5 Method of test to determine initial crush strength

The method of test for determining the initial crush strength is detailed in Annex B of this International Standard.

5.2.2 Flexural bending strength

5.2.2.1 General

When tested for bending strength in the saturated condition, according to the test method given in Annex C of this International Standard, pipes in the nominal size range DN 100 to DN 200 shall have breaking loads not less than the values given in Table 5.

NOTE The flexural bending strength test is a performance test that relates to the ability of the pipe to withstand axial flexure in service. The loads given in Table 5 do not represent the maximum service loads that can occur in service and apply to pipe lengths 3,6 m and longer.

Table 5 — Minimum breaking bending loads

DN mm	Class	Minimum breaking load in bending N
100	40 and 60	1 800
	90	2 400
	120	2 800
125	40 and 60	2 400
	90	3 200
	120	3 730
150	40 and 60	5 200
	90	6 600
	120	7 900
200	40 and 60	6 600
	90	8 380
	120	10 030

NOTE 1 This test is not a requirement for pipe larger than DN 200 or classes greater than 120.

NOTE 2 Break load values for classes intermediate between values given may be linearly interpolated.

5.2.2.2 Number of test pieces for type test purposes

Two test pieces, of the same size and classification and conforming to 5.2.3.3 shall be used.

5.2.2.3 Length of test pieces

The length, L_p , of the test piece shall be between 3 700 mm and 4 000 mm.

5.2.2.4 Conditioning of test piece

Specimens shall be immersed in water at an ambient temperature above 5 °C for a period of at least 28 days, immediately prior to testing.

5.2.2.5 Method of test

The method of test for determining the flexural bending strength is detailed in Annex C of this International Standard.

5.2.3 Initial leak tightness

5.2.3.1 General

When required, the initial leak tightness of pipes shall be assessed by the manufacturer using one of the following methods:

- a) using the test procedure given in Annex D, apply a test pressure of 250 kPa for a period of 30 s;
- b) using the test procedure given in Annex D, apply a test pressure of 100 kPa for a period of 1 min plus 30 s for every 10 mm of pipe wall thickness.

5.2.3.2 Leak test requirement

When tested in accordance with the requirements of 5.2.3.1, the pipe specimen shall exhibit no cracks or leakage.

Moisture appearing on the surface of the pipe in the form of damp patches shall not be considered as leakage. If, during the test, beads of water appear on the surface of the pipe, continue the test for an additional period of time equal to that of the initial period for the test. The pipe is accepted if the beads do not grow or run.

5.2.3.3 Number of test pieces for type test purposes

One test piece, of a size and class representative of the middle range of all pipes produced under the same conditions and conforming to 5.2.4.3, shall be used.

5.2.3.4 Length of test pieces

The test piece shall have a length of at least 0,3 m.

5.2.3.5 Method of test

The method of test for assessing the water tightness is given in Annex D of this International Standard.

5.2.3.6 Conditioning of test pieces

Specimens shall be stored in air at a temperature of (23 ± 5) °C and at (50 ± 10) % RH for 7^{+1}_0 days, immediately prior to testing.

5.2.4 Modulus of elasticity

5.2.4.1 General

When the value of the modulus of elasticity is required, it shall be determined using the test method given in Annex E.

NOTE Values of the initial pipe modulus of elasticity can be required when assessing the suitability of the pipe for buried installations (see Annex J).

5.2.4.2 Number of test pieces

Cut four test pieces from different pipes of the same size and class. Two sets of pipe sizes should be tested representing the manufacturer's smallest and largest pipe sizes.

5.2.4.3 Length of test pieces

The test piece shall have a length of (300 ± 5) mm and shall be cut from the barrel of the pipe.

5.2.5 Long-term pipe stiffness

5.2.5.1 General

The value of the long-term pipe stiffness, when required, shall be determined using the test method given in Annex F.

NOTE Values of the long-term pipe stiffness can be required when assessing the suitability of the pipe for buried installations (see Annex J).

5.2.5.2 Number of test pieces

Cut four test pieces from different pipes of the same size and class. Two sets of pipe sizes should be tested representing the manufacturer's smallest and largest pipe sizes.

5.2.5.3 Length of test pieces

The test piece shall have a length of (300 ± 5) mm and be cut from the barrel of the pipe.

5.3 Resistance to domestic sewage

5.3.1 General

When tested according to Annex G using the test media, the exposure times and temperatures specified in 5.3.2, 5.3.3 and 5.3.4, respectively, the ratio of the lower estimate mean values of the crush loads for the exposed and unexposed specimens determined at the 95 % confidence level, L , shall not be less than 0,75.

Pipes complying with this requirement shall be marked with the letter "S".

NOTE Compliance with this clause might not satisfy national regulatory requirements.

5.3.2 Test media

The test media shall be a solution of water containing the components given in Table 6.

Table 6 — Test media

Component	Concentration mg/l
Polysaccharide (starch)	50
Sodium stearate	32
Sodium acetate	56
Glycerine triacetate	15
Urea	13
Ammonium sulfate	70
Protein (albumin)	90
Industrial purity of components is required.	

5.3.3 Testing time

The test specimen shall be immersed in the test media for (28 ± 2) days.

5.3.4 Testing temperature

The test media shall be maintained at a temperature of (23 ± 5) °C.

5.4 Warm water test

5.4.1 General

When tested according to Annex G using warm water for the exposure times and temperature specified in 5.4.3 and 5.4.4 respectively, the ratio of the lower estimate mean values of the crush loads for the exposed and unexposed specimens determined at the 95 % confidence level L shall not be less than 0,75.

5.4.2 Test media

The test media shall be tap water.

5.4.3 Testing time

The test specimen shall be immersed in the test media for (56 ± 2) days.

5.4.4 Test temperature

The test media shall be maintained at a temperature of (60 ± 2) °C.

5.5 Marking of pipes

5.5.1 Marking details shall be printed or formed directly on the pipe in such a way that the marking does not initiate cracks or other types of failure.

5.5.2 If printing is used, the colouring of the printed information shall differ from the basic colouring of the product and the markings shall be readable without magnification.

5.5.3 The following marking shall be on the outside of each pipe:

- a) number of this International Standard;
- b) nominal size DN;
- c) crush strength class;
- d) manufacturer's name or identification;
- e) date or code of manufacture;
- f) code letter "S" for products suitable for the conveyance of sewerage.

6 Joints

6.1 General requirements

A joint made between pipes shall be designed so that its hydrostatic performance is equal to or better than the in-service requirements of the piping system but not necessarily of the components being joined.

NOTE Interchangeability between products from different manufacturers cannot be achieved without appropriate test evaluation to this International Standard relative to the different pipe and joint dimensions.

6.2 Joint geometrical requirements

6.2.1 Dimensions

The dimensions and the shape of all parts of the sleeves, sockets, pipe spigots and elastomeric rings shall be determined by the manufacturer of the pipes. The tolerances of dimensions influencing the hydrostatic performance of the joint assembly shall be established by the manufacturer, taking into account, when applicable, the effects of long-term creep or relaxation of the joint components.

The joint dimensions and range of tolerances shall allow assembly of the joint without damaging any components or adversely affecting the hydrostatic performance of the joint.

6.2.2 Requirements

The properties given in 6.2.1 shall be declared by the manufacturer for a particular design of joint.

6.3 Joint hydrostatic performance

6.3.1 Hydrostatic test

When tested according to the hydrostatic test procedures specified in Annex H, the joint shall not leak when subjected to an internal or external infiltration pressures for the test times specified in Table 7.

Table 7 — Internal pressure test schedule

Test Pressure kPa	Period of time min
0	5
20	10
100	30

6.3.2 Test with draw

Joints shall be capable of conforming to 6.3.1 when the maximum draw, D , declared by the manufacturer, is applied.

6.3.3 Test with angular deflection

Flexible joints shall be capable of conforming to 6.3.1 when an angular deflection, not less than the acceptable long-term installed deflection agreed between the purchaser and manufacturer, is applied.

6.3.4 Test with sideloading

Joints shall be capable of conforming to the requirements of 6.3.1 when a shear force, F_s , expressed in newtons, is applied to the joint assembly in the manner detailed in Annex H.

The value of F_s shall be 20 times DN where DN is the nominal diameter of the test specimen in millimetres.

6.3.5 Number of test pieces for type test purposes

The number of assemblies to be tested for each test shall be one.

The same assembly may be used for more than one test.

6.4 Marking of joints and fittings

6.4.1 Marking details shall be printed or formed directly on the coupling in such a way that the marking does not initiate cracks or other types of failure.

6.4.2 If printing is used, the colouring of the printed information shall differ from the basic colouring of the product and the markings shall be readable without magnification.

6.4.3 The following marking shall be on the outside of each coupling:

- a) number of this International Standard;
- b) nominal size DN;
- c) crush strength class;
- d) manufacturer's name or identification;
- e) date or code of manufacture;
- f) code letter "S" for products suitable for the conveyance of sewerage.

7 Handling and storage

Pipes shall be handled and, where necessary, stored in a manner such that

- a) they continue to be in a condition that complies with this International Standard;
- b) their shapes are not distorted so as to affect jointing, pressure tightness or water tightness;
- c) their surface and edge finishes are not damaged such that performance is affected.

Annex A (normative)

Test method for determination of pipe straightness

A.1 Scope

This annex sets out the test for determining the straightness of a pipe.

A.2 Principle

A full length of pipe placed upon supports is rotated and deviation of the centre of the pipe from the straight line between the supports is measured.

A.3 Apparatus

A.3.1 Supports for the pipe specimen, two, allowing the pipe to rotate about its longitudinal axis without longitudinal or horizontal displacement of the specimen.

The supports shall be positioned with their centres spaced at a distance equal to $2/3$ of the length of the pipe specimen.

A.3.2 Dial gauge, with a rounded measuring face capable of measuring to an accuracy of 0,1 mm, mounted on a fixed base.

A.4 Test specimen

The test specimen shall be a complete length of pipe.

A.5 Test procedure

Place the pipe horizontally on the two supports with the sliding spindle of the dial gauge on the outer surface of the pipe at a point equidistant between the supports.

Rotate the pipe on the supports for at least one complete revolution and measure the maximum deviation, f , indicated by the dial gauge, to the nearest millimetre (see Figure A.1).

A.6 Test report

The test report shall include the following information:

- a) reference to this International Standard;
- b) all details necessary for complete identification of the pipe tested;
- c) dimensions of each test piece;
- d) number of test pieces;

- e) equipment details;
- f) test temperature;
- g) maximum deviation, f ;
- h) date of the test.

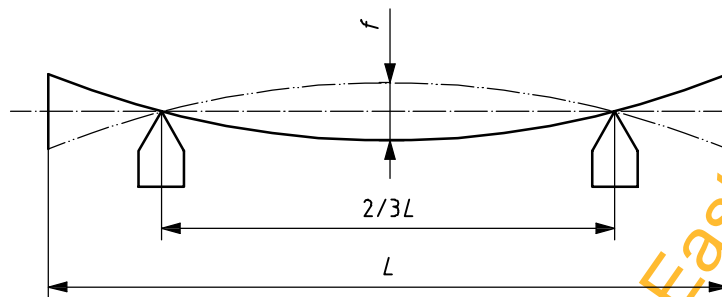

Figure A.1 — Determination of pipe straightness

Annex B (normative)

Test method for determination of pipe crush strength

B.1 Scope

This annex sets out the method for the determination of the pipe crush load under a compressive force applied using a three-edge bearing configuration.

B.2 Principle

A test specimen is placed between lower and upper press blocks. An increasing load is applied evenly to the test specimen at a constant rate until fracture occurs.

B.3 Apparatus

B.3.1 Loading rig

The loading rig shall be horizontal (see Figure B.1) and of sufficient size and rigidity such that deformation from application of the test load to the pipe specimen does not appreciably affect the validity or accuracy of the load measurement.

The loading rig shall be capable of applying the loads uniformly along the length of the pipe barrel at the specified rates. It shall be provided with a load-indicating device. Such a device shall be capable of measuring, either directly or indirectly, the total load being applied, to an accuracy of $\pm 2\%$ of its value, and be capable of recording a maximum load value.

B.3.2 Timber bearers

The timber bearers shall be of hardwood with cross-sectional dimensions as shown in Figure B.2 and of length not less than the external length of the barrel of the pipe being tested. The surfaces of the bearers in contact with the pipe shall be faced with rubber packing of hardness equivalent to Shore A of $50 \pm 5^\circ$ and the bearers shall be firmly fixed in the testing rig to prevent their movement during a test.

B.4 Specimen preparation

Measure the internal diameter, d_i , wall thickness, e , and length, L , of the specimen as follows.

- Mean internal diameter, d_i , of the test specimen shall be determined in accordance with 5.1.1.2.
- Wall thickness, e , in millimetres with an accuracy of 0,1 mm, shall be taken as the average of four measurements equally-spaced around the pipe prior to testing.
- Length, L , of the test specimen, in millimetres, with an accuracy of $\pm 0,5$ mm, shall be taken as the average of two measurements taken on opposite sides.

B.5 Specimen conditioning

B.5.1 Dry conditioning

Specimens which are to be tested in a dry condition shall be stored in air at a temperature of $(23 \pm 5)^\circ\text{C}$ and at $(50 \pm 10)\%$ RH for 7^{+1}_0 days, immediately prior to testing.

B.5.2 Wet conditioning

Specimens that are to be tested in a saturated condition shall be immersed in water at an ambient temperature above 5°C for a period of at least 28 days, immediately prior to testing.

Other conditioning methods that can be shown to give the same sample strength and steady state are acceptable. In the event of a dispute, the above wet-conditioning method shall be the reference test method.

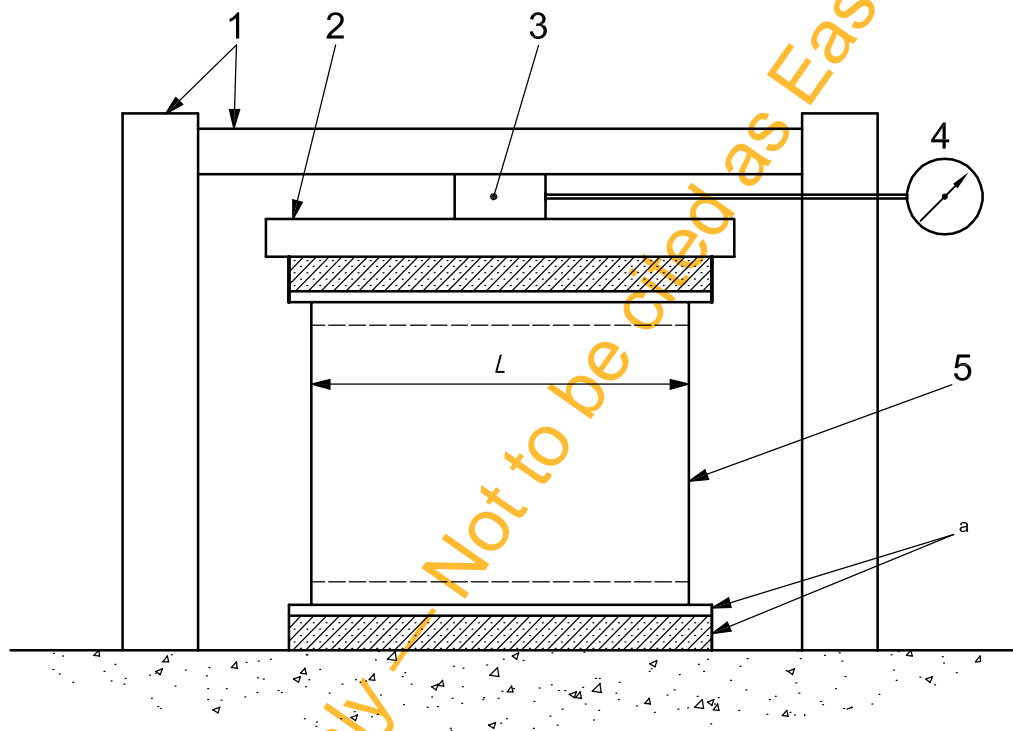

Key

- 1 rigid frame
- 2 loading beam
- 3 load power pack (in centre-line of bearer)
- 4 load indicator
- 5 sample pipe
- a For bearers and packing, see Figure B.2.

Figure B.1 — Schematic arrangement of horizontal loading rig

Dimensions in millimetres

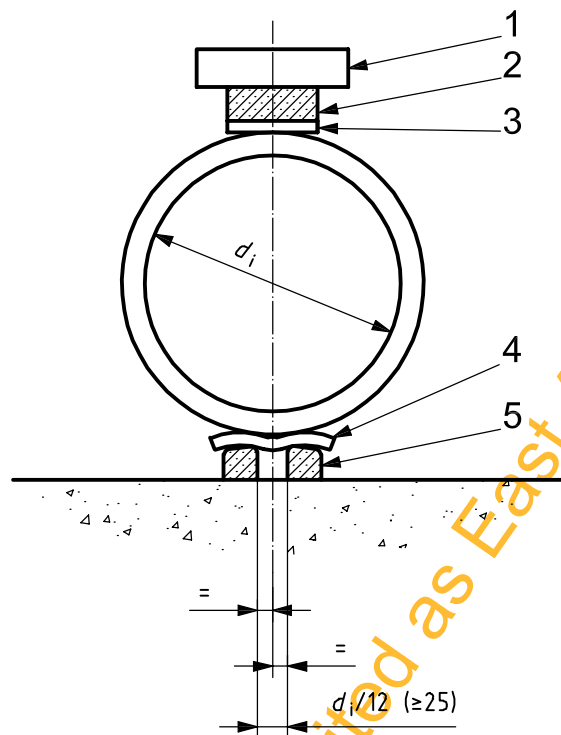
**Key**

- 1 loading beam
- 2 hardwood timber bearer 150 × 75
- 3 rubber packing 13 to 25 thick
- 4 rubber packing 13 to 25 thick
- 5 hardwood timber bearer 75 × 75

Figure B.2 — Schematic arrangement of bearers**B.6 Test procedure****B.6.1 Positioning of test specimen** (see Figure B.2)

Position the test specimen and the bearers in the loading rig such that

- a) the longitudinal axes of the test specimen and the bearers are parallel with one another and the bearers are symmetrically placed with respect to the diameter of the pipe cross-section;
- b) the line of action of the applied load lies in the plane of symmetry of the bearers.

B.6.2 Application of load

Loading shall be applied to the test specimen at a minimum steady rate of 4 kN/min/m so that failure occurs after at least 60 s. Record the maximum applied force, F , indicated by the testing machine.

The pipe specimen shall be carefully seated on the lower press block to ensure even contact along its full length and to avoid point load concentration. Similar care should be taken to align the upper press block. Any worn or damaged press block components should be replaced immediately.

B.7 Calculation of break load

The test load, designated P_d for the breaking load of a dry specimen, and P_s for the breaking load of a saturated specimen, both expressed in kilonewtons per metre, shall be calculated as given in Equation (B.1):

$$P_d = \frac{F}{L} \times 10^3 \text{ or } P_s = \frac{F}{L} \times 10^3 \quad (\text{B.1})$$

where

F is maximum force indicated by the test machine, expressed in kilonewtons;

L is length of test specimen, expressed in millimetres.

B.8 Test report

The test report shall include the following information:

- a) reference to this International Standard;
- b) all details necessary for complete identification of the pipe tested;
- c) dimensions of each test piece;
- d) number of test pieces;
- e) equipment details;
- f) test temperature;
- g) load at failure of the test specimen, expressed in kilonewtons per metre, to the nearest 0,1 kN/m;
- h) date of the test.

Annex C (normative)

Test method for determination of pipe flexural bending strength

C.1 Scope

This annex describes the method for determining the flexural strength of pipes with nominal diameters DN 100 to DN 200.

C.2 Principle

A full length of pipe is placed symmetrically on bearing blocks and a load is applied at intermediate points of the span until failure occurs.

C.3 Apparatus

C.3.1 Steel bearing blocks, two, each 50 mm long with a 120° V-shaped notch on one face and free to move in the plane of bending on two horizontal axes spaced 2 000 mm apart (see Figure C.1).

C.3.2 Steel load-applying blocks, two, 25 mm long, with a 120° V-shaped notch on one face, free to rotate about the transverse horizontal axis, spaced at intermediate points of the span of the supports.

C.3.3 Strips of rubber, (15 ± 5) mm thick and hardness (60 ± 5) IRHD and of the same area as the blocks interposed between the V-shaped notch of the blocks and the test specimen.

C.3.4 Load-testing machine, comprising a system of applying without shock, a compressive force at a controlled rate, with a loading error of ± 1 % of the maximum indicated load, capable of indicating the test load when failure occurs.

C.3.5 Gauges, for measuring pipe length, diameter and wall thickness.

C.4 Specimen conditioning

The test specimen shall be conditioned in air in a laboratory for 24 h prior to testing.

C.5 Test procedure

The procedure shall be as follows.

- a) Ensure that the test specimen rests symmetrically in the notches of the bearing blocks and extends at least 25 mm beyond the outer edges of the blocks (see Figure C.1). Place felt between the specimen and the blocks.
- b) Position two load-applying blocks at positions that are equidistant from each other and from the centre of the adjacent bearing block (see Figure C.1).
- c) Align the load-applying blocks so they are parallel to the common axis of the pipe and bearing blocks.

- d) Commence applying a load, distributed equally between the two load-applying blocks, at a regulated, constant rate, so that failure occurs after at least 25 s.
- e) Measure and record the total load, F , at failure of the test specimen.
- f) Measure and record the wall thickness in the region of the fracture and whether the area of fracture is outside the middle third section (see Figure C.1).

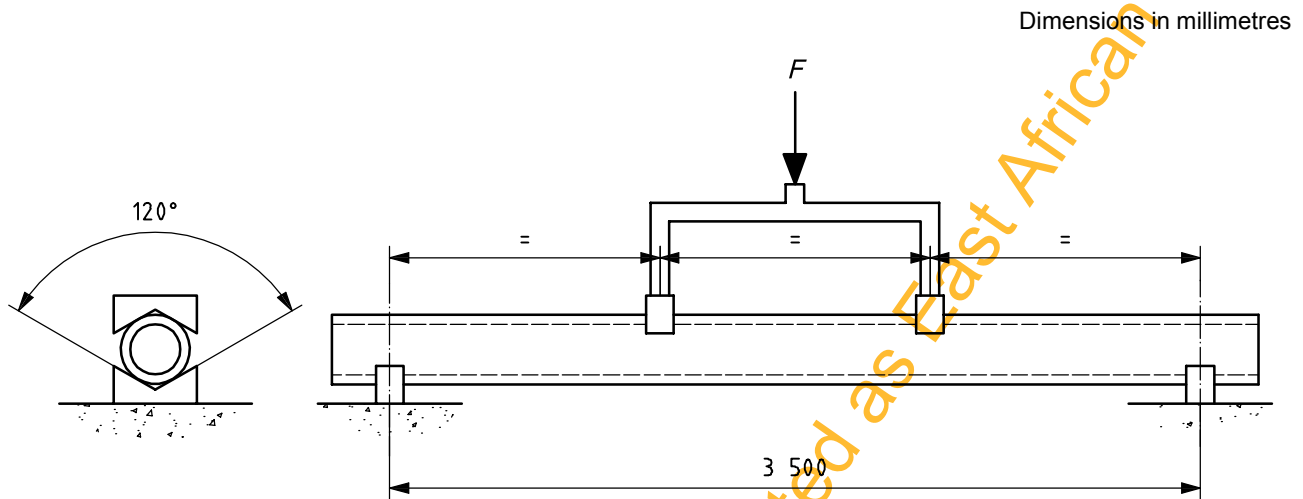

Figure C.1 — Schematic arrangement for the bending strength test

C.6 Test report

The test report shall include the following information:

- a) reference to this International Standard;
- b) all details necessary for complete identification of the pipe tested;
- c) dimensions of each test piece;
- d) number of test pieces;
- e) equipment details;
- f) test temperature;
- g) load at failure of the test specimen, expressed in kilonewtons per metre to the nearest 0,1 kN/m;
- h) date of the test.

Annex D (normative)

Test method for determination of watertightness

D.1 Scope

This annex describes the test procedure for assessing the watertightness of pipes.

D.2 Principle

A single or jointed test specimen is sealed at both ends and internal hydrostatic pressure is increased at a constant rate. At the appropriate level, the pressure is kept constant and the surface of the specimen is observed for the appearance of moisture.

D.3 Apparatus

D.3.1 Pressure equipment, capable of applying and sustaining the hydrostatic test pressure to the inside surface of the pipe to be tested.

D.3.2 Test ends, with elastomeric jointing rings, capable of reproducing the conditions of jointing used in the pipeline and capable of closing the ends of the pipe tightly. The test ends shall incorporate a connection through which hydrostatic pressure can be applied to the inside of the pipe and a means for the escape of air from within the pipe.

D.3.3 Pressure gauge, with a suitable pressure range and an accuracy to within 2 % over the whole range of measurements fitted to the pipeline transmitting the pressure.

NOTE See Figure D.1 for a schematic arrangement of the hydrostatic test rig.

D.4 Preparation of test specimen

The test specimen shall be prepared as follows.

- a) The pipe shall be surface-dry at the time of testing. It shall be supported so that the longitudinal axis is approximately horizontal and, except at the supports, the exterior surface shall be readily examinable. Where the testing of joints is specified (see Clause 6), the test pipes shall be deflected about the joint to the maximum angle recommended by the manufacturer.
- b) The ends of the pipe shall be closed by means of the test ends and elastomeric jointing rings specified in Clause D.3, in a manner that ensure that no leakage occurs through or past the closure during the test. The pipe shall then be filled with water and the air expelled.

D.5 Test procedure

The procedure shall be as follows.

- a) Apply pressure to the inside of the pipe until the test pressure, measured at the lowest point of the pipe, is reached. Maintain the test pressure on the pipe for the specified duration of the test (see 5.2.3.1).

- b) During the test, moisture appearing on the surface of the pipe in the form of damp patches shall not be considered as leakage.
- c) If, during the test, beads of water appear on the surface of the pipe or at the joint, maintain the pressure on the pipe for an additional period equal to the initial period required for the test. The pipe is accepted if the beads do not grow or run.

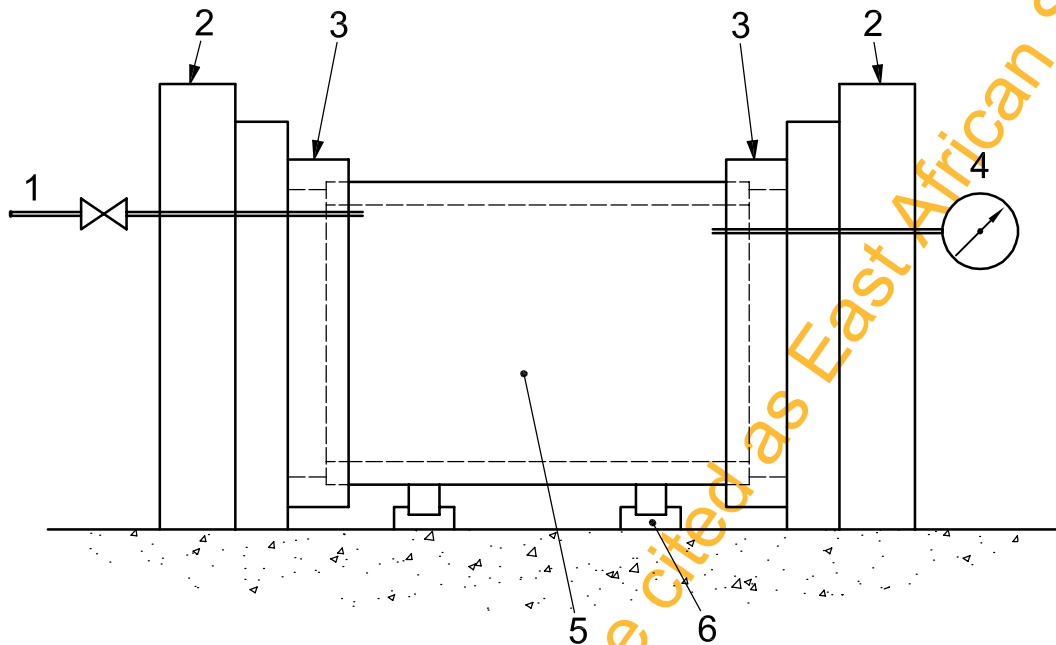

Key

- | | | | |
|---|-------------|---|---------------------|
| 1 | bleed pipe | 4 | pressure gauge |
| 2 | rigid frame | 5 | sample pipe |
| 3 | end cap | 6 | adjustable supports |

Figure D.1 — Schematic arrangement for leak tightness testing

D.6 Test report

The test report shall include the following information:

- a) reference to this International Standard;
- b) all details necessary for complete identification of the pipe tested;
- c) dimensions of each test piece;
- d) number of test pieces;
- e) equipment details;
- f) test temperature;
- g) test pressure and time of application;
- h) whether beads of water were observed on the surface of the test specimen;
- i) whether failure occurred indicated by growth of water beads;
- j) date of the test.

Annex E (normative)

Test method for determination of the modulus of elasticity

E.1 Scope

This annex sets out the method for determining the modulus of elasticity in ring bending of pipe and the stress and strain at maximum load.

E.2 Principle

A test specimen is placed between lower and upper test blocks. A load is applied evenly and at a constant rate between two set points and the change in diametrical deflection between the two load set points measured. The modulus of elasticity is calculated from the pipe dimensions, the load set points and the change in pipe diameter. The pipe is tested to its maximum load capacity. The deflection is measured at that load and from the pipe dimensions the stress and strain in the pipe are calculated at its maximum load capacity.

E.3 Apparatus

The test shall be carried out with the test equipment described in Annex B of this International Standard. In addition, the test equipment shall include a device set at both ends of the test specimen for measuring to an accuracy of 0,01 mm the vertical deformation of the internal diameter under load. The applied load and deflections are to be logged continuously at 1 s intervals throughout the test by means of a suitable data acquisition system.

E.4 Specimen preparation

The test specimens for the determination of the of elasticity shall be one of two cut from a pipe sample to a length of (300 ± 5) mm. The paired sample shall be kept for testing to Annex F. Test specimens shall be surface-dry and the barrel shall be free from

- a) dust or any matter which might obscure a crack, and
- b) any defect described in 4.3.

The recommended minimum sample size is six specimens.

E.5 Measurement of pipe dimensions

Measure the mean internal diameter, d_i , wall thickness, e , length, L , and vertical deformation, Δ_v , of the test specimens as follows.

- a) Mean internal diameter, d_i , of the test specimen shall be determined by taking two measurements mutually at right angles and 200 mm from each end. The mean internal diameter shall be taken as the mean of the four values. Alternatively, the mean internal diameter may be determined by measuring the average external diameter with a diameter tape and subtracting the mean of four measurements of wall thickness taken at equal intervals around the circumference.

- b) Wall thickness, e , expressed in millimetres, shall be the average of four measurements with an accuracy of 0,1 mm equally spaced around the pipe prior to testing.
- c) Length, L , of the test specimen, expressed in millimetres with an accuracy of 0,5 mm, shall be the average of two measurements on opposite sides.
- d) Vertical deformation, Δ_v , of the test specimen shall be the average of two measurements at each end of the test specimen with an accuracy of 0,01 mm.

E.6 Specimen conditioning

Specimens for the determination of the saturated modulus of elasticity, E_{BS} , shall be tested after immersion in water for at least 28 days.

E.7 Test procedure

E.7.1 Positioning the test specimen and measuring device

Position the test specimen and the bearers in the loading rig such that

- a) the longitudinal axes of the test specimen and the bearers are parallel with one another and the bearers are symmetrically placed with respect to the diameter of the pipe cross section;
- b) the line of applied load lies in the plane of symmetry of the bearers.

The pipe specimen shall be seated on the lower press block to ensure even contact along its full length to avoid point load concentration. The upper press block shall be similarly aligned.

Insert the measuring device for the measurement of pipe deformation approximately 30 mm inside the pipe as measured from the pipe end and at each end of the pipe.

E.7.2 Load application

Commence loading the pipe with the data acquisition system operating.

The load shall be applied to the test specimen at either a constant rate of load application, or a constant rate of test machine crosshead deflection, such that failure occurs after 1 min, but before 3 min.

E.7.3 Data collection

The following data shall be recorded during testing to pipe failure (see Figure E.1):

- a) maximum load, F_{max} , expressed in kilonewtons;
- b) deflection, Δ_{max} , at F_{max} , expressed in millimetres;
- c) lower load set point, $F_{low} \cong 3\%$ of F_{max} , expressed, in kilonewtons;
- d) deflection at F_{low} , expressed in millimetres;
- e) upper load set point, $F_{upp} \cong 30\%$ of F_{max} , expressed, in kilonewtons;
- f) deflection at F_{upp} , expressed in millimetres;
- g) deflection difference, Δ_v , between F_{low} and F_{upp} , expressed in millimetres.

E.8 Calculation of modulus of elasticity

Calculate the modulus of elasticity within the linear region of the load-deflection curve as given by Equation (E.1) (see Figure E.1):

$$E_{BS} = \frac{223,2(F_{\text{upp}} - F_{\text{low}})(d_i + e)^3}{\Delta_v L e^3} \quad (\text{E.1})$$

NOTE This calculation ignores the curvature of the pipe, the material shear modulus and Poisson's ratio. This does not introduce a significant error.

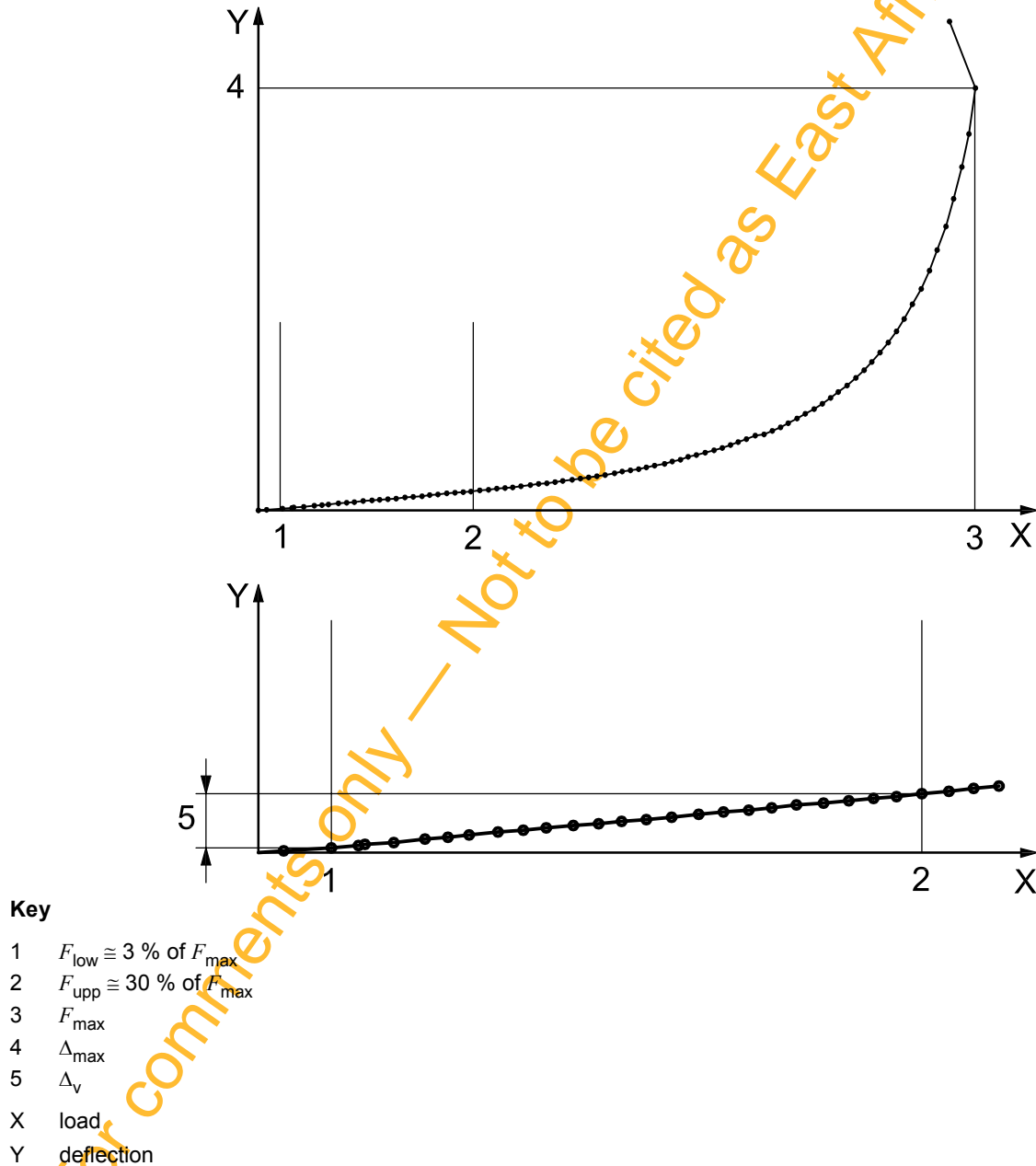

Figure E.1 — Typical modulus of elasticity test data points

E.9 Calculation of stress and strain at maximum load

Calculate the material stress at maximum load as given by Equation (E.2):

$$\sigma_{\max} = \frac{954,9F_{\max}(d_i + e)}{Le^2} \quad (\text{E.2})$$

NOTE This calculation ignores the curvature of the pipe. This does not introduce a significant error.

Calculate the material strain at maximum load as given by Equation (E.3):

$$\varepsilon_{\max} = \frac{4,279\Delta_{\max}e}{(d_i + e)^2} \quad (\text{E.3})$$

NOTE This calculation ignores the material shear modulus and Poisson's ratio. This does not introduce a significant error.

E.10 Test report

The test report shall include the following information:

- a) reference to this International Standard;
- b) all details necessary for complete identification of the pipe tested;
- c) dimensions of each test piece;
- d) number of test pieces;
- e) equipment details;
- f) test temperature and condition of the test piece;
- g) loads F_{low} and F_{upp} , the load F_{max} , the vertical deformation, Δ_v , and the maximum deflection Δ_{max} ;
- h) calculated values for the saturated modulus of elasticity in bending, E_{BS} , the calculated maximum bending stress, σ_{max} , and the calculated strain, ε_{max} , at maximum bending stress;
- i) date of the test.

Annex F (normative)

Test method for determination of the long-term pipe stiffness

F.1 Scope

This annex specifies the procedure for determining the saturated long-term stiffness and the saturated long-term apparent ring-bending modulus of elasticity of a pipe.

F.2 Principle

A section of saturated pipe is subjected to a sustained deflection similar to the deflection that it can experience when installed in a buried condition. The deflection is maintained at a constant magnitude and the changes in the load required to maintain this deflected condition of pipe are measured. The extrapolated long-term load determined from the load-time relationship is used to calculate the long-term apparent stiffness of the pipe and the long-term apparent ring-bending modulus of the pipe material. The long-term apparent ring-bending modulus of the pipe material can then be used to calculate the saturated long-term stiffness of other pipes of other sizes and classes.

F.3 Apparatus

A suitable apparatus (see Figure F.1) consists of the following.

- F.3.1 Tank**, designed to hold the pipe specimen immersed in water.
- F.3.2 Load beam**, designed to apply a force to a load cell.
- F.3.3 Load cell**, capable of indicating the applied force with an accuracy of 0,5 %.
- F.3.4 Transfer beam**, designed to transfer that force to a pipe specimen.
- F.3.5 Support beam**, designed to provide the reaction force to the pipe specimen.

The apparatus shall have a stiffness such that the deflection of the apparatus at the test load is less than 1 % of the deflection of the pipe specimen under test. The tank shall be filled with fresh tap water at ambient temperature and a nominal pH of 7 at the commencement of the test. The pipe shall be maintained fully submerged for the duration of the test.

Precautions shall be taken to avoid temperature changes of the water in the tank, which can affect the results of the test. It is recommended that the apparatus be placed in an air-conditioned laboratory where the temperature is controlled at all times for the duration of the test.

F.4 Specimen selection and preparation

The test specimens shall be one of two cut from a pipe sample to a minimum length of (300 ± 5) mm (the second sample from Annex E).

The surfaces of the barrel shall be free from

- a) dust or any matter that can obscure a crack, and
- b) any defect described in 4.3.

The recommended minimum sample size is six specimens.

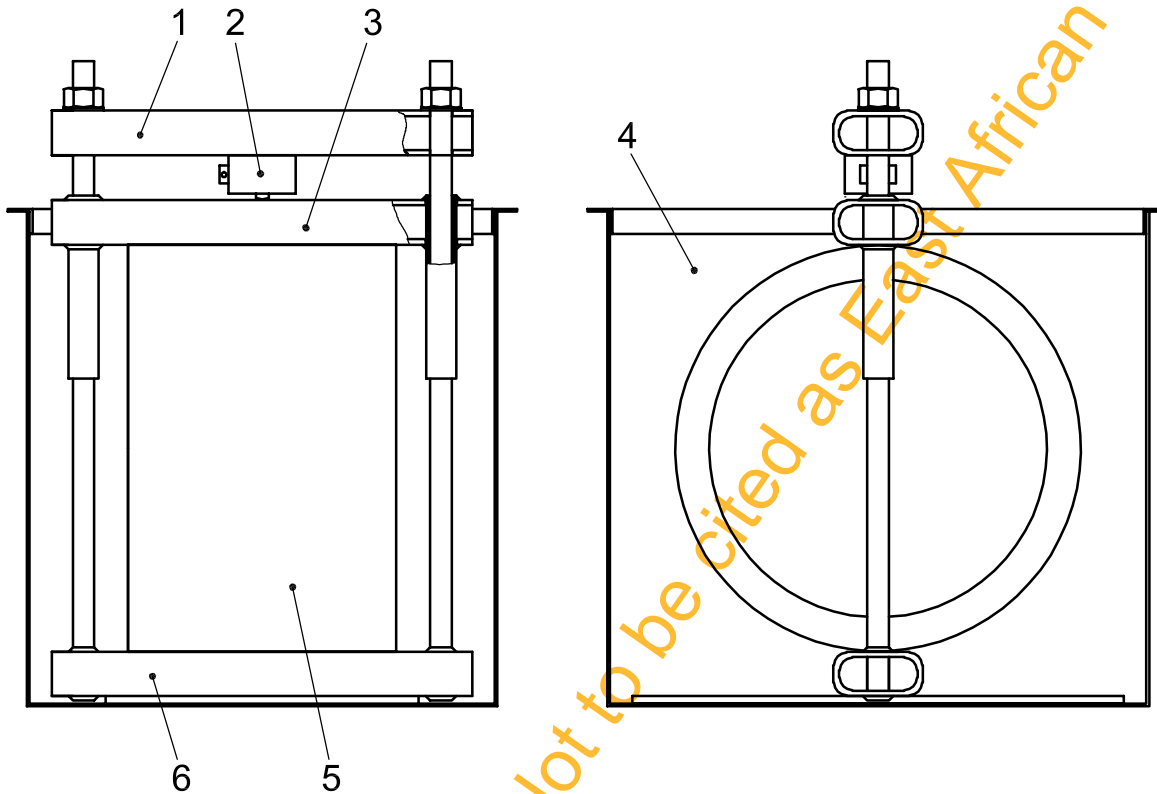

Key

- 1 loading beam
- 2 load cell
- 3 transfer beam
- 4 tank
- 5 pipe specimen
- 6 support beam

Figure F.1 — Typical stress relaxation test apparatus

F.5 Measurement of specimen dimensions

Measure the internal diameter, d_i , wall thickness, e , and length, L , of the specimen as follows.

- a) Mean internal diameter, d_i , of the test specimen shall be determined in accordance with E.5.
- b) All thickness, e , in millimetres with an accuracy of 0,1 mm shall be taken as the average of four measurements equally spaced around the pipe prior to testing.
- c) Length, L , of the test specimen in millimetres with an accuracy of 0,5 mm shall be taken as the average of two measurements taken on opposite sides.

F.6 Specimen conditioning

Specimens tested in a saturated condition shall be immersed in water at an ambient temperature above 5 °C for a period of at least 28 days, immediately prior to testing.

Other conditioning methods that can be shown to give the same sample strength and steady state are acceptable. In the event of a dispute, the above conditioning method shall be the reference test method.

F.7 Initial relaxation test load

The initial relaxation test load, P_R , shall be the calculated load required to cause the maximum pipe deflection predicted in the long-term, buried, installed condition.

NOTE 1 The initial relaxation test load cannot exceed the value of the initial design load, i.e. P_R is less than the minimum initial crush load divided by the installation safety factor.

NOTE 2 Information concerning the calculation of the initial relaxation test load is contained in Annex J.

F.8 Test Procedure

The saturated pipe specimen shall be placed in the test apparatus under water and left unloaded for a period of at least 6 h to attain thermal equilibrium with the apparatus.

The saturated pipe specimen shall then be loaded to within 5 % of the initial test load, P_R . The loading shall be completed over a period of time of less than 1 min and the deflection of the pipe shall be maintained constant for the remainder of the test.

The load on the pipe shall be logged at intervals of time commencing at the time of initial loading. The observations shall include measurements at time intervals of approximately 1 h, 2 h, 5 h, 8 h, 25 h, 50 h, 100 h, 200 h, 500 h, 1 000 h, 2 000 h, 5 000 h and 10 000 h.

F.9 Calculation of results

The data collected from the stress-relaxation test shall be analysed in accordance with ISO 10928. The method of calculation shall be that which returns the best quality of the linear coefficient of correlation.

Data points in addition to those specified in Clause F.8 may be used in the calculation of the results in order to improve the accuracy of the calculation. If additional data points are included in the calculation, then they shall be censored so as to be in a geometric progression in order to give an even weighting on the time axis after a logarithmic transform is applied.

The data analysis may be used to predict a future material property based on the duration of tests and the analysis of ISO 10928. The furthest extrapolation of the data analysis shall be to a time where the logarithm of the extrapolated time is not greater than 50 % of the logarithm of the actual test time.

The data analysis shall be used to predict the long-term load, P_{R2} , expected to be recorded at 2 years (17,520 h).

The predicted long-term saturated stiffness, S_{S2} , of the pipe at 2 years is given by Equation (F.1):

$$S_{S2} = \frac{S_S P_{R2}}{P_R} \quad (\text{F.1})$$

The predicted saturated long-term apparent bending modulus of elasticity of the pipe at 2 years is given by Equation (F.2):

$$E_{BS2} = \frac{E_{BS} P_{R2}}{P_R} \quad (\text{F.2})$$

F.10 Test frequency

The determination of the saturated long-term stiffness and saturated long-term apparent ring-bending modulus of elasticity shall be repeated when the manufacturer changes the design, method of manufacture or materials.

F.11 Test report

The test report shall include the following information:

- a) reference to this International Standard;
- b) all details necessary for complete identification of the pipe tested;
- c) dimensions of each test piece;
- d) number of test pieces;
- e) equipment details;
- f) test temperature and condition of the test piece;
- g) initial relaxation load applied to the specimen;
- h) calculated values for the saturated modulus of elasticity in bending, E_{BS} ;
- i) date of the test.

Annex G (normative)

Method of determination of resistance to liquid media

G.1 Scope

This annex gives a method for evaluating the change in pipe strength resulting from exposure to liquids.

G.2 Principle

The effect of exposure to the media is evaluated by comparing the initial crush strength of the pipe with the value of the pipe crush strength after a period of immersion in the media.

G.3 Apparatus

G.3.1 Tank, capable of holding the media of sufficient size to allow immersion of the test specimen.

G.3.2 Means of maintaining temperature of the media in the tank, at the temperature specified in the reference standard.

G.3.3 Test media, as specified in 5.3.2.

G.3.4 Crush testing apparatus, as detailed in Annex B.

G.4 Preparation of test specimens

Specimens shall be cut from a single uncoated pipe of nominal diameter DN 150 or from the smallest diameter pipe produced by the manufacturer.

20 specimens, having lengths suitable for crush testing by the method described in Annex B, shall be cut and numbered as shown in Figure G.1; the test specimens with the same number shall be called paired test specimens.

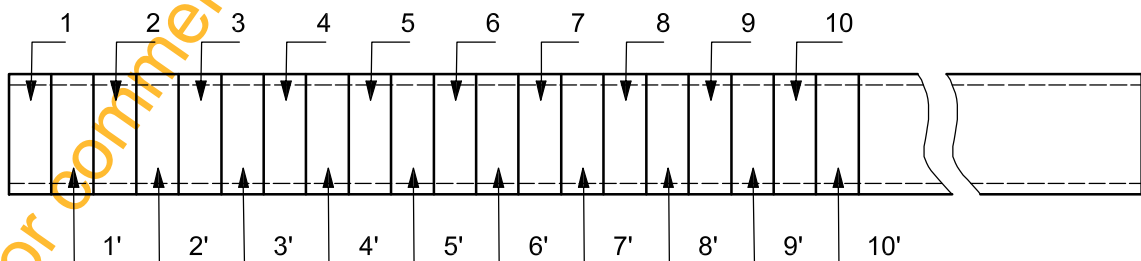

Figure G.1 — Cutting of paired test specimens

G.5 Test procedure

- a) Divide the paired specimens into two lots of 10 specimens numbered 1 to 10 and 1' to 10', respectively.
- b) The specimens numbered 1 to 10 shall be tested according to the procedure in Annex B for saturated specimens.
- c) The specimens numbered 1' to 10' shall be immersed in the test media for the period of time specified in the reference standard, then removed from the test media and allowed to stand for 7 days at the ambient laboratory condition.
- d) The specimens should then be tested according to the procedure in Annex B, including the preliminary conditioning required for saturated specimens.

G.6 Evaluation of test results

For each pair of test specimens ($n = 1$ to 10), calculate the individual ratio, r_n , as given in Equation (G.1):

$$r_n = t_n / c_n \quad (\text{G.1})$$

where

t_n is the crush break load of the specimen immersed in the test media, expressed in kilonewtons per metre;

c_n is the crush break load of the control test specimen, expressed in kilonewtons per metre.

Calculate the average, r_m , and standard deviation, s , of the individual ratios, r_n .

Calculate the lower 95 % confidence limit, L , of the average ratio, r_m , as given in Equation (G.2):

$$L = r_m - 0,58s \quad (\text{G.2})$$

By agreement between the manufacturer and the certifying body an alternative mechanical test comparing ring bending strength before and after immersion in the test media may be used.

G.7 Test report

The test report shall include the following information:

- a) reference to this International Standard;
- b) all details necessary for complete identification of the pipe tested;
- c) dimensions of each test piece;
- d) number of test pieces;
- e) equipment details;
- f) testing media, test temperature and condition of the test piece;
- g) break loads of the specimens;
- h) calculated values for the paired specimen strength ratios, r_n , their average value, r_m , and lower confidence limit, L ;
- i) date of the test.

Annex H (normative)

Test method for determination of joint performance under hydrostatic pressure

H.1 Scope

This annex gives requirements for assessing the joint performance when subjected to hydrostatic pressure

H.2 Principle

A pipe joint is subjected to internal and external hydrostatic pressure and shearing forces when assembled at its maximum design draw and deflection conditions to determine if leakage occurs.

H.3 Apparatus

H.3.1 Test rig, capable of supporting the joint and its adjacent pipes and capable of withstanding the forces resulting from the hydrostatic test pressure.

H.3.2 Sealing and closure devices, for the pipe ends.

H.3.3 Equipment for filling test specimen with water and allowing evacuation of air.

H.3.4 Pressure-measuring equipment, accurate to within 0,01 MPa (0,1 bar).

H.3.5 Pump or similar device, for increasing hydrostatic pressure.

H.3.6 Timing device.

H.3.7 Apparatus or device that permits joint to be pressurized externally.

NOTE A joint with the sealing ring groove section especially machined facing in the opposite direction to the normal joint and with the sealing ring(s) fitted in the reverse direction to normal allows the testing of test specimen by internal pressure.

H.3.8 Device capable of applying shear load to joint.

H.4 Test specimen

The test specimen is one assembled joint together with connecting pipes or pieces of pipe.

The dimensions of the joint shall give the minimum sealing ring compression allowed by the manufacturer.

The same assembly may be used for more than one test.

H.5 Method of test

H.5.1 Test of straight joint

H.5.1.1 Internal pressure test

- a) Assemble the joint and fit the necessary end caps and seals to the ends of the pipes.
- b) Install the test specimen, without axial deflection or draw, into the test rig and secure pipes and end fittings to prevent end movement occurring when under pressure.
- c) Fill the specimen with water and bleed out all residual air.
- d) Apply water pressure to the test specimen in accordance with the test sequence given in Table H.1.
- e) Inspect the specimen during the test and report if there are any drops of water or water loss.

Table H.1 — Internal pressure test schedule

Test pressure kPa	Period of time min
0	5
20	10
100	30

H.5.1.2 External pressure test

- a) Assemble the joint in a manner suitable for applying external pressure to the joint.
- b) Repeat the testing sequence specified in H.5.1.1 b) to d).

H.5.2 Test of deflected joint

H.5.2.1 Internal pressure test

- a) Assemble the joint and fit the necessary end caps and seals to the ends of the pipes.
- b) Install the test specimen, with maximum deflection and draw specified by the manufacturer (see Figure 1) into the test rig and secure pipes and end fittings to prevent end movement occurring when under pressure.
- c) Fill the specimen with water and bleed out all residual air.
- d) Apply water pressure to the test specimen in accordance with the test sequence given in Table H1.
- e) Inspect the specimen during the test and report if there are any drops of water or water loss.

H.5.2.2 External pressure test

- a) Assemble the joint in a manner suitable for applying external pressure to the joint.
- b) Repeat the testing sequence detailed in H5.2.1 b) to d).

H.5.3 Test of joint with applied shear load

Assemble the test specimen as detailed in H.5.1.1 together with a device for applying a shear load across the joint (see Figures H.1 and H.2).

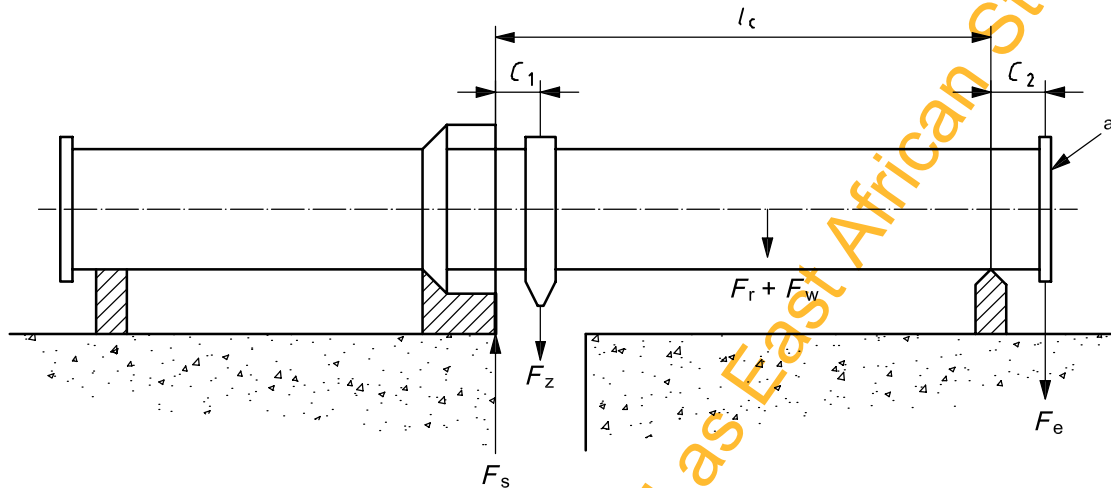

- ^a A cap or plug equipped with devices for filling, air evacuation and protected against force caused by the test pressure.

Figure H.1 — Socket joint test with shear load

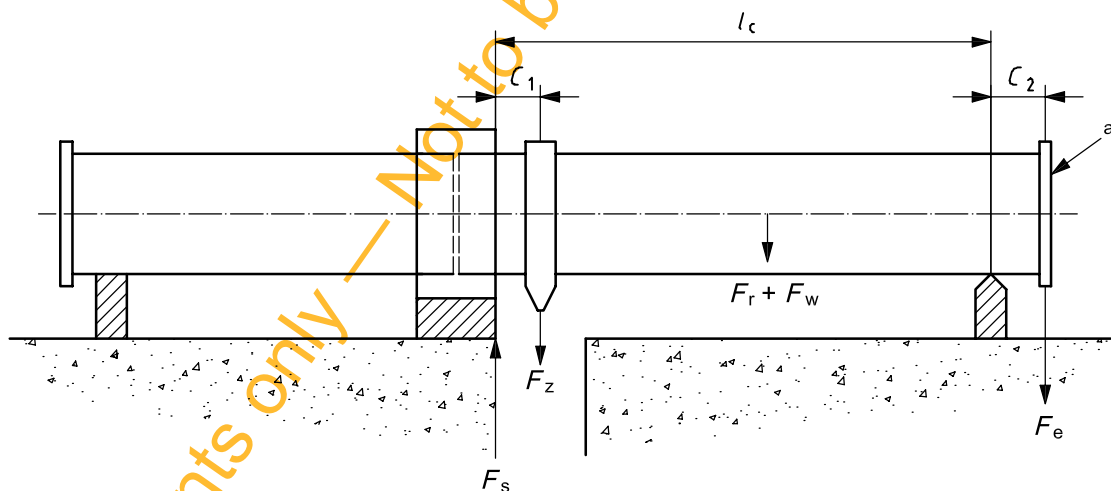

- ^a A cap or plug equipped with devices for filling, air evacuation and protected against force caused by the test pressure.

Figure H.2 — Sleeve joint test with shear load

H.5.3.1 Determination of shear load for socketed pipe

The shear load is the sum of any applied loads, the weight of the pipe, the weight of water in the pipe and the weights of the test apparatus (depending upon the test arrangement).

The additional load, F_z , expressed in newtons, that it is necessary for the testing apparatus to apply to produce a shear load, F_s , is given by Equation H.1:

$$F_z = [1/(l_c - c_1)] \times [F_s \times l_c + F_e \times c_2 - (F_r + F_w) \times (l_c - c_1)/2] \quad (\text{H.1})$$

where

l_c is the distance between joints and mid-support, expressed in metres (see Figures H.1 and H.2);

c_1 is the distance between joints and axis of F_z , expressed in metres (see Figures H.1 and H.2);

c_2 is the distance between support and axis of F_e ;

F_e is the weight of the cap or plug, expressed in newtons;

F_r is the weight of the pipe, expressed in newtons;

F_s is the shear load (see 6.3.4), expressed in newtons;

F_w is the weight of the water contents (pipe with shear load), expressed in newtons.

H.5.3.2 Test procedure

- a) Following application of the additional load, the internal pressure shall be applied in accordance with H.5.1.1 d).

NOTE The value of F_s varies according to type of joint (see 6.3.4).

- b) Examine specimen for signs of leakage.

H.6 Test report

The test report shall include the following information:

- a) reference to this International Standard;
- b) all details necessary for complete identification of the pipe tested;
- c) dimensions of each test piece;
- d) number of test pieces;
- e) equipment details;
- f) test temperature and condition of the test piece;
- g) draw, angular deviation and shear load applied during test;
- h) whether leakage was observed;
- i) date of the test.

Annex I (informative)

Test method for determination of wet/dry crush factor

I.1 Scope

This annex describes a method for determining the dry/wet strength factor, W .

I.2 Principle

An equal number of dry and saturated test specimens are subjected to test loads.

I.3 Procedure for wet and dry load testing

Select sufficient test samples to provide 60 test specimens for wet and dry load testing. The specimens shall be prepared as follows.

- a) 30 specimens prepared in accordance with Clause B.4 and dry conditioned in accordance with B.5.1.
- b) 30 specimens prepared in accordance with Clause B.4, and wet conditioned in accordance with B.5.2.

Test specimens shall be load-tested in accordance with Annex B.

I.4 Calculation of wet/dry strength factor

Calculate the 97,5 % lower confidence limit of the failure load, P_d , of the dry sample, expressed in kilonewtons per metre, and of the failure load, P_s , of the saturated sample, expressed in kilonewtons per metre, using Student's "t" distribution.

The dry/wet strength factor, W , is given by Equation (I.1):

$$W = \frac{P_{dLC}}{P_{sLC}} \quad (I.1)$$

where

P_{dLC} is the breaking load of the dry specimen, expressed in kilonewtons per metre;

P_{sLC} is the breaking load of the saturated specimen, expressed in kilonewtons per metre.

I.5 Test report

The test report shall include the following information:

- a) reference to this International Standard;
- b) all details necessary for complete identification of the pipe tested;

- c) dimensions of each test piece;
- d) number of test pieces;
- e) equipment details;
- f) test temperature and condition of the test piece;
- g) break loads of the specimens;
- h) calculated value of the wet/dry factor, W ;
- i) date of the test.

Draft for comments only — Not to be cited as East African Standard

Annex J (informative)

Installation design of fibre-reinforced cement pipes

J.1 Introduction

The selection of fibre-reinforced cement pipes for buried installations may be made using either rigid-pipe or flexible-pipe design principles. It is generally considered more convenient for installation designers, in drainpipe applications, to use rigid-pipe principles and select pipe by using standardized installation configurations with nominated pipe crush load classes.

Rigid pipe principles were originally used for asbestos cement pipe design, but, as pipes became larger, it was recognized that there was a degree of flexibility in the product that enable the pipes, in diameters greater than DN 600, to obtain added support from the soil. This characteristic was recognized with the publishing of ISO 2785:1974 [2] and this was based upon the design principles developed in the German standard ATV 127 [3].

The development of asbestos-free products in recent years has altered some of the physical characteristics of fibre-reinforced cement pipes and, although these new products have lower strengths than asbestos cement, they now possess greater strain capacity, larger differences between wet and dry strengths and an increased capacity for creep. These changes mean that pipe products can exhibit ring stiffness values which may range from 400 000 N/m² to 100 000 N/m² (and lower). This flexibility adds a significantly higher ultimate load-carrying capability to the installation than predicted when using rigid-pipe design principles.

Notwithstanding, the ability of the pipe to be designed for in-ground use using flexible design principles, it is more convenient for the manufacturer to design and manufacture pipes using rigid-installation design methods. One benefit is that quality assurance can be made using a three-edge bearing test (e.g. as described in Annex B rather than a stiffness test, which is difficult to conduct on a high-stiffness pipe. Additionally, pipe crush-class classifications can be similar to other rigid pipes such as steel-reinforced concrete and the installation design can be the same as the standardized installation designs used for rigid concrete pipes, thus making it simpler for the pipeline designer to specify and produce tenders for competitive materials.

Rigid-pipe installation design principles do not consider pipe flexibility or pipe creep because these characteristics, in long-established products such as asbestos cement, steel reinforced and unreinforced concrete, are relatively small when compared to other materials and do not significantly influence the long-term performance of the products. Hence, only values of the initial pipe strength are used and long-term properties are not considered when using those materials. When using rigid-design parameters (i.e. three-edge bearing load) for the selection of the newer fibre-reinforced products, it is necessary to determine whether the long-term strain experienced by the pipe lies within the products acceptable performance limits.

The intention of this annex is to show how the fibre-reinforced cement pipes manufactured to the requirements of this International Standard can be shown to be suitable for installation using standardized rigid-pipe installation principles and accepted for design on the basis of their initial load-bearing capacity assessed using a three-edge bearing test.

J.2 Principle

Rigid-pipe installation design determines the pressures that are applied to the pipe in the ground resulting from the soil load on the pipe, static loads and live loads from traffic. A design factor or factor of safety is applied to the total of those applied pressures and then that value is converted to an equivalent three-edge bearing line load, using the installation bedding factor appropriate to the type of installation configuration being

used. This load represents the minimum initial load-bearing strength of the product that should be selected for the installation.

Pipes manufactured to this International Standard are designed to satisfy prescribed minimum initial crush loads that, for convenience, are based upon designated crush pressure class values, and the product is assessed for quality assurance purposes using a three-edge bearing load test. As cementitious products' strengths vary as a function of the moisture content of the product, this International Standard specifies minimum product crush-strength values for the product's wet condition, but, in recognizing that the time required to saturate the product is extensive, testing is usually conducted in the semi-dry condition and the product is tested to satisfy a higher minimum strength requirement equivalent to the dry strength, i.e. the wet crush value, T_c , times the wet/dry factor, W .

The crush load for a buried fibre-reinforced cement pipe is usually required to be 1,5 times the maximum design loading calculated using rigid-pipe design principles when in a saturated condition and when Equation (J.5) is satisfied.

Fibre-reinforced cement pipes, like plastics pipes, creep and deflect with time; thus, as the surrounding soil consolidates, changes occur in the forces being applied to the pipe resulting in changes to the strain in the pipe wall. In order to ensure that the rigid-pipe design assumptions are not compromised in these long-term conditions, it is, therefore, necessary to ensure that the installed pipe strain does not exceed reasonable safety levels.

Flexible pipe-installation design principles are used to assess the long-term safety characteristic of the pipe. The deflection of the pipe/soil system is calculated using pipe flexural moduli and ultimate deflection values together with long-term stiffness values determined from type tests. Calculations appropriate to each of the installation configurations specified in the applicable national rigid pipe design code are made using the soil moduli. From these calculations, it can be determined whether the long-term installed pipe strain provides an adequate margin of safety when compared to the measured ultimate strain of the pipe.

Results obtained by subjecting flexible pipes either to long-term testing creep testing or long-term relaxation testing to determine long-term stiffness clearly do not simulate the buried conditions where pipe movement is restrained by the surrounding soil. During the last two decades, experience with installed plastic pipes has shown that pipes normally achieve close to their maximum installed deflection after two years, hence this time period is recommended for calculating the value of the long-term stiffness of the pipe (see Annex F) used in calculating the long-term pipe/soil system installed deflection.

As there are variations in the soil moduli values used in the various national flexible pipe design codes as well as the configurations of the standardized installation design methods, the following basic type test procedure is presented in general terms and must be adapted to the national requirements of the country in which the pipe is used.

J.3 Determination of maximum soil prism load pressure

For each size and class of pipe, the maximum soil prism load pressure on the pipe, w_q , expressed in kilopascals, shall be calculated for the pipe installation designed as a rigid pipe using Marston/Spangler design procedures in an embankment installation with positive projection bedding calculated as given in Equation (J.1):

$$w_q = (T_c \cdot F_b) / (SF \cdot C'_e \cdot d_o) \cdot 10^3 \quad (J.1)$$

where

w_q is the soil prism pressure on the pipe, expressed in kilopascals;

T_c is the break load of pipe, expressed in kilopascals per metre;

F_b is the bedding factor for rigid-pipe installation design;

C'_e is the Spangler coefficient for rigid-pipe installation design (max. value 1,68 for $H/d_o > 10$);

d_o is the mean external diameter;

SF is a factor of safety (typically 1,5) consistent with that applied to the crush load of the specified class and size of pipe, T_u , to achieve a pipe long-term design load for installation.

J.4 Determination long-term characteristics

J.4.1 Initial modulus

In order to calculate the long-term pipe-strain characteristic in the installed condition, it is necessary to know the pipe initial modulus of elasticity, as well as its maximum strain and stress at maximum load. These can be determined using the test procedure given in Annex E.

J.4.2 Long-term stiffness

The long-term pipe stiffness is determined using the method specified in Annex F. This is a relaxation test where the pipe specimen is deflected to a defined level and the change in the load value required to maintain that deflection is measured with time. The initial deflection applied to the specimen in this test is equal to the calculated long-term deflection experienced in the pipe installation. The value of the installation deflection is calculated using Equation (J.2) and the actual value of the initial relaxation test load, P_R , required to produce the deflection in the test specimen is determined by examination of the load/deflection trace of the matching test specimen tested as described in Annex E (see J.4.4).

J.4.3 Determination of maximum long-term installed deflection

For each size and class of pipe, the maximum, long-term, saturated deflection shall be calculated for the pipe in all standard installations, when designed as a flexible pipe, by the Spangler modified LOWA equation, as given in Equation (J.2). In these calculations, the minimum native soil and back-fill modulus shall be 2 MPa.

$$\Delta_y / (d_i + e) = (K \cdot W_q \cdot 10^{-3}) / (8 \cdot S_{S2} \cdot 10^6 + 0,061E') \quad (J.2)$$

where

$$S_{S2} = (E_{BS2} \cdot I) / (d_i + e)^3 \cdot 10^6; \quad (J.3)$$

$$I = e^3 / 12 \text{ (for uniform wall thickness pipe)} \quad (J.4)$$

NOTE For profiled wall pipes, I is determined by other means.

K is the bedding constant (value 0,1);

W_q is the soil prism load pressure, expressed in kilopascals [see Equation (J.1)];

E' is the effective combined soil modulus (of embedment and surrounding soil), expressed in megapascals;

E_{BS2} is the apparent pipe modulus of elasticity at two years.

J.4.4 Determination of initial relaxation test load, P_R

The initial relaxation test load, P_R , is that required in ring bending to give a deflection of the pipe specimen equivalent to that determined in J.4.3, which may not exceed T_u .

NOTE The test specimens are prepared in matched pairs for the determination of MOE and long-term stiffness. Minor difference in wall thickness between the MOE specimen and the long-term stiffness specimen do not significantly affect the long-term stiffness result as this test load is setting the nominal value of the test load at which to determine the long-term stiffness.

J.5 Determination of whether semi-rigid pipe can be assessed on basis of three-edge bearing test

In order to assess whether a semi-rigid fibre-reinforced cement pipe can be accepted for use in a normal rigid-pipe installation, each pipe diameter and class should be examined to determine whether the pipe has sufficient flexibility for long-term service. The long-term pipe data determined by the test procedures in Annexes E and F establishes whether the pipe design satisfies the requirements specified in a) to d) below:

- a) at the average pipe manufacturing wall thickness, e_a ;
- b) the material predicted saturated long-term modulus of elasticity, E_{BS2} , at the lower 90 % confidence level using a Student's "t" distribution;
- c) the material saturated strain at maximum load in ring bending, ϵ_{max} , at the lower 90 % confidence level using a Student's "t" distribution;
- d) if

$$\frac{\epsilon_{max} C'_e \cdot d_o \left[E_{BS2} e_a^3 + 1,5 \cdot (d_i + e_a)^3 \cdot 0,061 \cdot E \right]}{6,419 \cdot e_a \cdot (d_i + e_a)^2 \cdot K \cdot (T_u / SF) \cdot F_b} \leq 2,0 \quad (J.5)$$

where SF is a factor of safety (typically 1,5) consistent with that applied to the crush load of the specified class and size of pipe, T_u , to achieve a pipe long-term design load for installation,

then the pipe has the required deflection capability.

When Equation (J.5) is not satisfied for any specific class and size of pipe, that pipe is not semi-rigid and should not be considered for installation in the conditions specified in J.4.3. The size and class should be installed with a consideration of rigid-pipe design principles in accordance with the national requirements of the country in which the pipe is used, and with a consideration of the long-term creep characteristics of that pipe.

Bibliography

- [1] ISO 3126, *Plastics piping systems — Plastics components — Determination of dimensions*
- [2] ISO 2785:1974¹⁾, *Guide to the selection of asbestos-cement pipes subject to external loads with or without internal pressure*
- [3] ATV 127, *Static Calculation of Drains and Sewers*

1) Withdrawn and replaced by ISO 2785:1986.

Draft for comments only — Not to be cited as East African Standard