



## EAST AFRICAN STANDARD

---

Plastics piping systems for non-pressure underground drainage and sewerage — Structured-wall piping systems of unplasticized poly(vinyl chloride) (PVC-U), polypropylene (PP) and polyethylene (PE) — Part 1: Material specifications and performance criteria for pipes, fittings and system

EAST AFRICAN COMMUNITY

---

## Foreword

Development of the East African Standards has been necessitated by the need for harmonizing requirements governing quality of products and services in East Africa. It is envisaged that through harmonized standardization, trade barriers which are encountered when goods and services are exchanged within the Community will be removed.

In order to meet the above objectives, the EAC Partner States have enacted an East African Standardization, Quality Assurance, Metrology and Test Act, 2006 (EAC SQMT Act, 2006) to make provisions for ensuring standardization, quality assurance, metrology and testing of products produced or originating in a third country and traded in the Community in order to facilitate industrial development and trade as well as helping to protect the health and safety of society and the environment in the Community.

East African Standards are formulated in accordance with the procedures established by the East African Standards Committee. The East African Standards Committee is established under the provisions of Article 4 of the EAC SQMT Act, 2006. The Committee is composed of representatives of the National Standards Bodies in Partner States, together with the representatives from the private sectors and consumer organizations. Draft East African Standards are circulated to stakeholders through the National Standards Bodies in the Partner States. The comments received are discussed and incorporated before finalization of standards, in accordance with the procedures of the Community.

Article 15(1) of the EAC SQMT Act, 2006 provides that "Within six months of the declaration of an East African Standard, the Partner States shall adopt, without deviation from the approved text of the standard, the East African Standard as a national standard and withdraw any existing national standard with similar scope and purpose".

East African Standards are subject to review, to keep pace with technological advances. Users of the East African Standards are therefore expected to ensure that they always have the latest versions of the standards they are implementing.

© East African Community 2010 — All rights reserved\*

East African Community

P O Box 1096

**Arusha**

Tanzania

Tel: 255 27 2504253/8

Fax: 255-27-2504481/2504255

E-Mail: [eac@eachq.org](mailto:eac@eachq.org)

Web: [www.each.int](http://www.each.int)

---

\* © 2010 EAC — All rights of exploitation in any form and by any means reserved worldwide for EAC Partner States' NSBs.

## Introduction

In the preparation of this East African Standard, the following source was consulted extensively:

ISO 21138-1:2007, *Plastics piping systems for non-pressure underground drainage and sewerage — Structured-wall piping systems of unplasticized poly(vinyl chloride) (PVC-U), polypropylene (PP) and polyethylene (PE) — Part 1: Material specifications and performance criteria for pipes, fittings and system*

Assistance derived from this source and others inadvertently not mentioned is hereby acknowledged.

Draft for comments only — Not to be cited as East African Standard

---

---

**Plastics piping systems for non-pressure  
underground drainage and sewerage —  
Structured-wall piping systems of  
unplasticized poly(vinyl chloride)  
(PVC-U), polypropylene (PP) and  
polyethylene (PE) —**

**Part 1:  
Material specifications and performance  
criteria for pipes, fittings and system**

*Systèmes de canalisations en plastique pour les branchements  
et les collecteurs d'assainissement sans pression enterrés — Systèmes  
de canalisations à parois structurées en poly(chlorure de vinyle)  
non plastifié (PVC-U), polypropylène (PP) et polyéthylène (PE) —*

*Partie 1: Spécifications des matières et critères de performance  
des tubes, raccords et système*



**PDF disclaimer**

This PDF file may contain embedded typefaces. In accordance with Adobe's licensing policy, this file may be printed or viewed but shall not be edited unless the typefaces which are embedded are licensed to and installed on the computer performing the editing. In downloading this file, parties accept therein the responsibility of not infringing Adobe's licensing policy. The ISO Central Secretariat accepts no liability in this area.

Adobe is a trademark of Adobe Systems Incorporated.

Details of the software products used to create this PDF file can be found in the General Info relative to the file; the PDF-creation parameters were optimized for printing. Every care has been taken to ensure that the file is suitable for use by ISO member bodies. In the unlikely event that a problem relating to it is found, please inform the Central Secretariat at the address given below.



**COPYRIGHT PROTECTED DOCUMENT**

© ISO 2007

All rights reserved. Unless otherwise specified, no part of this publication may be reproduced or utilized in any form or by any means, electronic or mechanical, including photocopying and microfilm, without permission in writing from either ISO at the address below or ISO's member body in the country of the requester.

ISO copyright office  
Case postale 56 • CH-1211 Geneva 20  
Tel. + 41 22 749 01 11  
Fax + 41 22 749 09 47  
E-mail [copyright@iso.org](mailto:copyright@iso.org)  
Web [www.iso.org](http://www.iso.org)

Published in Switzerland

## Contents

Page

Foreword.....	iv
Introduction .....	v
<b>1 Scope .....</b>	<b>1</b>
<b>2 Normative references .....</b>	<b>1</b>
<b>3 Terms, definitions, symbols and abbreviated terms.....</b>	<b>3</b>
3.1 Terms and definitions.....	3
3.2 Symbols .....	6
3.3 Abbreviated terms .....	7
<b>4 Material .....</b>	<b>7</b>
4.1 General.....	7
4.2 Sealing ring retaining components.....	7
4.3 Sealing rings .....	7
4.4 Fused or welded joints .....	7
<b>5 Designation of wall construction .....</b>	<b>7</b>
<b>6 Colour .....</b>	<b>8</b>
<b>7 Geometrical characteristics.....</b>	<b>8</b>
<b>8 Types of fitting .....</b>	<b>8</b>
8.1 General.....	8
8.2 Design length of fittings.....	11
<b>9 Functional characteristics .....</b>	<b>11</b>
<b>10 Relation between ring stiffness, installation technique and resulting deflection .....</b>	<b>11</b>
<b>Annex A (informative) General material characteristics of PVC-U, PP and PE pipes and fittings.....</b>	<b>13</b>
<b>Annex B (informative) General performance characteristics of PVC-U, PP and PE pipes and fittings .....</b>	<b>14</b>
<b>Annex C (informative) Structural design.....</b>	<b>15</b>
<b>Bibliography .....</b>	<b>18</b>

## Foreword

ISO (the International Organization for Standardization) is a worldwide federation of national standards bodies (ISO member bodies). The work of preparing International Standards is normally carried out through ISO technical committees. Each member body interested in a subject for which a technical committee has been established has the right to be represented on that committee. International organizations, governmental and non-governmental, in liaison with ISO, also take part in the work. ISO collaborates closely with the International Electrotechnical Commission (IEC) on all matters of electrotechnical standardization.

International Standards are drafted in accordance with the rules given in the ISO/IEC Directives, Part 2.

The main task of technical committees is to prepare International Standards. Draft International Standards adopted by the technical committees are circulated to the member bodies for voting. Publication as an International Standard requires approval by at least 75 % of the member bodies casting a vote.

Attention is drawn to the possibility that some of the elements of this document may be the subject of patent rights. ISO shall not be held responsible for identifying any or all such patent rights.

ISO 21138-1 was prepared by Technical Committee ISO/TC 138, *Plastics pipes, fittings and valves for the transport of fluids*, Subcommittee SC 1, *Plastics pipes and fittings for soil, waste and drainage (including land drainage)*.

ISO 21138 consists of the following parts, under the general title *Plastics piping systems for non-pressure underground drainage and sewerage — Structured-wall piping systems of unplasticized poly(vinyl chloride) (PVC-U), polypropylene (PP) and polyethylene (PE)*:

- *Part 1: Material specifications and performance criteria for pipes, fittings and system*
- *Part 2: Pipes and fittings with smooth external surface, Type A*
- *Part 3: Pipes and fittings with non-smooth external surface, Type B*

## Introduction

ISO 21138 is the system standard covering the plastics piping systems for non-pressure underground drainage and sewerage, in particular thermoplastics structured-wall piping systems.

*Draft for comments only — Not to be cited as East African Standard*

*Draft for comments only — Not to be cited as East African Standard*

# Plastics piping systems for non-pressure underground drainage and sewerage — Structured-wall piping systems of unplasticized poly(vinyl chloride) (PVC-U), polypropylene (PP) and polyethylene (PE) —

## Part 1: Material specifications and performance criteria for pipes, fittings and system

### 1 Scope

This part of ISO 21138 specifies the definitions and requirements for pipes, fittings and the system based on unplasticized poly(vinyl chloride) (PVC-U), polypropylene (PP) and polyethylene (PE) structured-wall piping systems in the field of non-pressure underground systems for underground drainage and sewerage.

NOTE 1 These pipes, fittings and the system can be used for highway drainage and surface water.

This part of ISO 21138 specifically refers to PVC, PP and PE materials.

NOTE 2 Other thermoplastic materials can be added via an addendum.

This part of ISO 21138 covers a range of pipe and fitting sizes, materials, pipe constructions, nominal ring stiffnesses, and gives recommendations concerning colours.

NOTE 3 It is the responsibility of the purchaser or specifier to make the appropriate selections from these aspects, taking into account their particular requirements and any relevant national regulations and installation practices or codes.

In conjunction with ISO 21138-2 and ISO 21138-3, it is applicable to PVC-U, PP and PE structured-wall pipes and fittings, to their joints and to joints with components of other plastics and non-plastics materials intended to be used for buried piping systems for the transport of drainage and sewerage.

It is applicable to PVC-U, PP and PE structured-wall pipes and fittings with or without an integral socket with elastomeric ring seal joints as well as welded and fused joints.

NOTE 4 Pipes, fittings and other components conforming to any plastics product standards referred to in Clause 2 can be used with pipes and fittings conforming to this part of ISO 21138 when they conform to the requirements for joint dimensions given in Parts 2 and 3 of ISO 21138 and to the performance requirements given in Clause 9.

NOTE 5 For dimensions larger than DN/OD 1200 or DN/ID 1200, this part of ISO 21138 can serve as a general guide regarding appearance, colour, physical and mechanical characteristics as well as performance requirements.

### 2 Normative references

The following referenced documents are indispensable for the application of this document. For dated references, only the edition cited applies. For undated references, the latest edition of the referenced document (including any amendments) applies.

ISO 472, *Plastics — Vocabulary*

ISO 580:2005, *Plastics piping and ducting systems — Injection-moulded thermoplastics fittings — Methods for visually assessing the effects of heating*

ISO 1043-1:2001, *Plastics — Symbols and abbreviated terms — Part 1: Basic polymers and their special characteristics*

ISO 1133:2005, *Plastics — Determination of the melt mass-flow rate (MFR) and the melt volume-flow rate (MVR) of thermoplastics*

ISO 1167-1, *Thermoplastics pipes, fittings and assemblies for the conveyance of fluids — Determination of the resistance to internal pressure — Part 1: General method*

ISO 1167-2, *Thermoplastics pipes, fittings and assemblies for the conveyance of fluids — Determination of the resistance to internal pressure — Part 2: Preparation of pipe test pieces*

ISO 1183-1, *Plastics — Methods for determining the density of non-cellular plastics — Part 1: Immersion method, liquid pycnometer method and titration method*

ISO 2505, *Thermoplastics pipes — Longitudinal reversion — Test method and parameters*

ISO 2507-1, *Thermoplastics pipes and fittings — Vicat softening temperature — Part 1: General test method*

ISO 2507-2, *Thermoplastics pipes and fittings — Vicat softening temperature — Part 2: Test conditions for unplasticized poly(vinyl chloride) (PVC-U) or chlorinated poly(vinyl chloride) (PVC-C) pipes and fittings and for high impact resistance poly(vinyl chloride) (PVC-HI) pipes*

ISO 3126, *Plastics piping systems — Plastics components — Determination of dimensions*

ISO 3127, *Thermoplastics pipes — Determination of resistance to external blows — Round-the-clock method*

ISO 4435, *Plastics piping systems for non-pressure underground drainage and sewerage — Unplasticized poly(vinyl chloride) (PVC-U)*

ISO 8772, *Plastics piping systems for non-pressure underground drainage and sewerage — Polyethylene (PE)*

ISO 8773, *Plastics piping systems for non-pressure underground drainage and sewerage — Polypropylene (PP)*

ISO 9852, *Unplasticized poly(vinyl chloride) (PVC-U) pipes — Dichloromethane resistance at specified temperature (DCMT) — Test method*

ISO 9967, *Thermoplastics pipes — Determination of creep ratio*

ISO 9969, *Thermoplastics pipes — Determination of ring stiffness*

ISO 11173, *Thermoplastics pipes — Determination of resistance to external blows — Staircase method*

ISO 11357-6, *Plastics — Differential scanning calorimetry (DSC) — Part 6: Determination of oxidation induction time (isothermal OIT) and oxidation induction temperature (dynamic OIT)*

ISO 11922-1:1997, *Thermoplastics pipes for the conveyance of fluids — Dimensions and tolerances — Part 1: Metric series*

ISO 12091:1995, *Structured-wall thermoplastics pipes — Oven test*

ISO 13967, *Thermoplastics fittings — Determination of ring stiffness*

ISO 21138-2:2007, *Plastics piping systems for non-pressure underground drainage and sewerage — Structured-wall piping systems of unplasticized poly(vinyl chloride) (PVC-U), polypropylene (PP) and polyethylene (PE) — Part 2: Pipes and fittings with smooth external surface, Type A*

ISO 21138-3:2007, *Plastics piping systems for non-pressure underground drainage and sewerage — Structured-wall piping systems of unplasticized poly(vinyl chloride) (PVC-U), polypropylene (PP) and polyethylene (PE) — Part 3: Pipes and fittings with non-smooth external surface, Type B*

EN 681-1, *Elastomeric seals — Materials requirements for pipe joint seals used in water and drainage applications — Part 1: Vulcanized rubber*

EN 681-2, *Elastomeric seals — Materials requirements for pipe joint seals used in water and drainage applications — Part 2: Thermoplastic elastomers*

EN 681-4, *Elastomeric seals — Materials requirements for pipe joint seals used in water and drainage applications — Part 4: Cast polyurethane sealing elements*

EN 1053, *Plastics piping systems — Thermoplastics piping systems for non-pressure applications — Test method for watertightness*

EN 1277, *Plastics piping systems — Thermoplastics piping systems for buried non-pressure applications — Test methods for leaktightness of elastomeric sealing ring type joints*

EN 1446, *Plastics piping and ducting systems — Thermoplastics pipes — Determination of ring flexibility*

EN 1979, *Plastics piping and ducting systems — Thermoplastics spirally-formed structured-wall pipes — Determination of the tensile strength of a seam*

EN 12061, *Plastics piping systems — Thermoplastics fittings — Test method for impact resistance*

EN 12256, *Plastics piping systems — Thermoplastics fittings — Test method for mechanical strength or flexibility of fabricated fittings*

EN 14741, *Thermoplastics piping and ducting systems — Joints for buried non-pressure applications — Test method for the long-term sealing performance of joints with elastomeric seals by estimating the sealing pressure*

### 3 Terms, definitions, symbols and abbreviated terms

For the purposes of this document, the following terms, definitions, symbols and abbreviated terms apply.

#### 3.1 Terms and definitions

In addition to the terms and definitions given below, the terms and definitions given in ISO 472, ISO 1043-1 and ISO 11922-1 apply.

##### 3.1.1 General terms

###### 3.1.1.1

###### **structured-wall pipes and fittings**

products that have an optimized design with regard to material usage to achieve the physical, mechanical and performance requirements of this part of ISO 21138

NOTE For a description of the particular designs covered by this part of ISO 21138, see ISO 21138-2 for Type A and ISO 21138-3 for Type B. Type A pipes have an internal and external plain surface. Type B pipes have an internal plain surface and a hollow spiral or annular ribbed external surface.

**3.1.1.2**

**fabricated fitting**

fitting manufactured by heat forming and/or joining more than one piece of pipe and/or moulded component

NOTE Sealing rings retaining components are not considered as a piece.

**3.1.2 Geometrical terms**

**3.1.2.1**

**nominal size DN**

numerical designation of the size of a component, other than a component designated by thread size, which is approximately equal to the manufacturing dimension in millimetres

**3.1.2.2**

**nominal size DN/OD**

nominal size, related to the outside diameter

**3.1.2.3**

**nominal size DN/ID**

nominal size, related to the inside diameter

**3.1.2.4**

**nominal diameter**

$d_n$   
specified diameter, in millimetres, assigned to a nominal size (DN/OD or DN/ID)

**3.1.2.5**

**outside diameter**

$d_e$   
value of the measurement of the outside diameter through its cross-section at any point of a pipe or spigot, rounded to the next greater 0,1 mm

NOTE For Type B constructions, see ISO 21138-3.

**3.1.2.6**

**mean outside diameter**

$d_{em}$   
value of the measurement of the outer circumference of a pipe or spigot in any cross-section divided by  $\pi$  (= 3,142), rounded up to the nearest 0,1 mm

NOTE For Type B constructions, see ISO 21138-3.

**3.1.2.7**

**mean inside diameter**

$d_{im}$   
average value of a number of equally spaced measurements of inside diameter in the same cross-section of a pipe or fitting

**3.1.2.8**

**minimum mean inside diameter of a socket**

$D_{im,min}$   
average value of equally spaced measurements of inside diameter in the same cross-section of a socket

**3.1.2.9**

**wall thickness**

$e$   
measured wall thickness at any point of the body of a component

### 3.1.2.10 construction height

$e_c$   
radial distance between the top of ribs or corrugation or, in the case of Type A1 and Type A2 pipes and fittings, between the outside surface of the wall and the inside surface of the wall

### 3.1.2.11 wall thickness of the inside layer waterway wall thickness

$e_4$   
(Type A1) thickness at any point of the inner layer of a pipe or fitting

See Figure 1 in ISO 21138-2:2007.

(Type B) thickness at any point of the wall between the ribs or corrugations of the pipe or fitting

See Figure 4 in ISO 21138-3:2007.

### 3.1.2.12 wall thickness of the inside layer under a hollow section

$e_5$   
thickness at any point of the inside wall between a hollow section and the inside surface of the Type A2 or Type B pipe or fitting

See Figure 2 in ISO 21138-2:2007 and Figure 4 in ISO 21138-3:2007.

### 3.1.2.13 minimum length of a spigot

$L_{1,min}$   
minimum permitted value for the length of a spigot of a pipe or fitting

### 3.1.2.14 nominal ring stiffness SN

numerical designation of the ring stiffness of the pipe or fitting, which is a convenient round number, indicating the minimum required ring stiffness of the pipe or stiffness of the fitting

### 3.1.2.15 fitting stiffness

mechanical characteristic of a fitting, which is a measure of the resistance to ring deflection under an external force as determined in accordance with ISO 13967

## 3.1.3 Material terms

### 3.1.3.1 virgin material

material in a form such as granules or powder, which has not been subjected to use or processing other than that required for its manufacture and to which no reprocessible or recyclable materials have been added

### 3.1.3.2 own reprocessible material

material prepared from rejected unused pipes or fittings, including trimmings from the production of pipes and fittings, which will be reprocessed in a manufacturer's plant after having been previously processed by the same manufacturer by a process such as moulding or extrusion and for which the complete formulation is known

### 3.1.3.3 external reprocessible material

material comprising either one of the following:

- a) material from rejected unused pipes or fittings, or trimmings therefrom, that will be reprocessed and that were originally processed by another manufacturer;
- b) material from the production of unused thermoplastics products other than pipes and fittings, regardless of where they are manufactured

#### 3.1.3.4

##### **recyclable material**

material comprising either one of the following:

- a) material from used pipes or fittings that have been cleaned and crushed or ground;
- b) material from used thermoplastics products other than pipes or fittings which have been cleaned and crushed or ground

### 3.2 Symbols

$a$	circumferential cover by a saddle branch
$D_{im,min}$	minimum mean inside diameter of a socket
$d_e$	outside diameter
$d_{em}$	mean outside diameter
$d_{im}$	mean inside diameter
$d_n$	nominal diameter
$d_{n1}$	nominal diameter of the main of a branch/saddle branch
$d_{n2}$	nominal diameter of the branch of a branch/saddle branch
$d_s$	inside diameter of socket
$e$	wall thickness (at any point)
$e_2$	wall thickness of the socket
$e_3$	wall thickness of the groove area
$e_4$	wall thickness of the inside layer (waterway wall thickness)
$e_5$	wall thickness of the inside layer under a hollow section
$e_c$	construction height
$L$	axial cover by a saddle branch
$L_{1,min}$	minimum length of a spigot
$Z_1$	design length of a fitting
$Z_2$	design length of a fitting
$Z_3$	design length of a fitting
$\alpha$	nominal angle of a fitting

### 3.3 Abbreviated terms

DN/ID	nominal size related to inside diameter
DN/OD	nominal size related to outside diameter
ID	inside diameter
OD	outside diameter
PE	polyethylene
PP	polypropylene
PVC-U	unplasticized poly(vinyl chloride)
S	pipes series S
SDR	standard dimension ratio
SN	nominal ring stiffness

## 4 Material

### 4.1 General

The material shall be one of those specified in the relevant Annexes of ISO 21138-2 and/or ISO 21138-3.

Information about general material characteristics is given in Annex A.

### 4.2 Sealing ring retaining components

It is permitted that sealing rings be retained using components made from polymers other than PVC-U, PP or PE.

### 4.3 Sealing rings

The sealing ring material shall conform to EN 681-1, EN 681-2 or EN 681-4, as applicable.

The sealing ring shall have no detrimental effects on the properties of the components.

### 4.4 Fused or welded joints

When fused or welded joints are used, the manufacturer's instructions for jointing shall be followed.

## 5 Designation of wall construction

Designations of wall constructions including schematic sketches and examples of typical jointing methods are given in ISO 21138-2 for Type A pipes (inside and outside smooth) and in ISO 21138-3 for Type B pipes (inside smooth and outside structured).

## 6 Colour

The inner and outer layer of pipes and fittings shall be coloured throughout.

NOTE The outside layer of pipes and fittings should preferably be black, orange-brown (approximately RAL 8023, see [5]) or dusty grey (approximately RAL 7037, see [5]). Other colours may be used.

## 7 Geometrical characteristics

This part of ISO 21138 specifies the following nominal sizes. Other dimensions are permitted.

Nominal sizes: DN/ID
100, 125, 150, 200, 225, 250, 300, 400, 500, 600, 800, 1000, 1200
Nominal sizes: DN/OD
110, 125, 160, 200, 250, 315, 400, 500, 630, 800, 1000, 1200

## 8 Types of fitting

### 8.1 General

This part of ISO 21138 is applicable for the following types of fitting. Other designs of fitting, including all sockets and all spigots, are permitted.

a) Bends, swept and unswept angle (see Figure 1 and Figure 2).

NOTE 1 Preferred nominal angles,  $\alpha$ , are the following: 15°, 22,5°, 30°, 45° and between 87,5° and 90°.

b) Couplers and slip couplers (see Figure 3).

c) Reducers (see Figure 4).

d) Branches and reducing branches, swept and unswept entry (see Figure 5).

NOTE 2 Preferred nominal angles,  $\alpha$ , are 45° and between 87,5° and 90°.

e) Saddle branches for solvent cementing, fusion or welding (see Figure 6):

— the axial cover,  $L$ , in millimetres, shall conform to the following:

Dimensions in millimetres

	$d_{n2} \leq 110$	$110 < d_{n2} \leq 125$	$125 < d_{n2} \leq 160$	$160 < d_{n2} \leq 200$
$L$	$\geq 50$	$\geq 60$	$\geq 70$	$\geq 80$

— for saddles having  $d_{n1} < 315$  mm the cover shall be not less than half a circumference, see Figure 6<sup>a</sup>;

— for saddles having  $d_{n1} \geq 315$  mm the circumferential cover,  $a$ , shall not be less than 80 mm, see Figure 6<sup>b</sup>.

NOTE 3 The preferred nominal angle,  $\alpha$ , for saddle branches is 45°. When  $(d_{n2}/d_{n1}) \leq 2/3$ , the nominal angle,  $\alpha$ , can be 90°.

f) Plugs (see Figure 7).

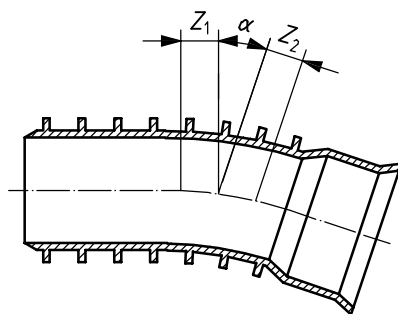

Figure 1 — Example of an unswept bend

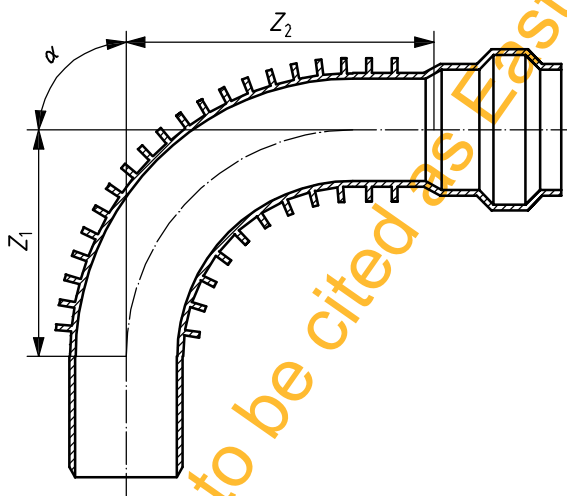

Figure 2 — Example of a swept bend

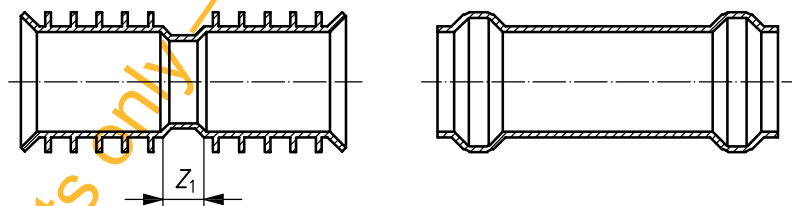

Figure 3 — Example of a coupler and slip coupler

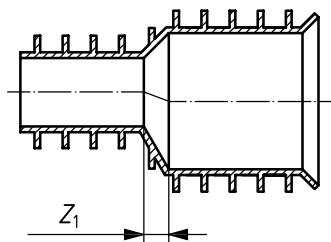

Figure 4 — Example of a reducer

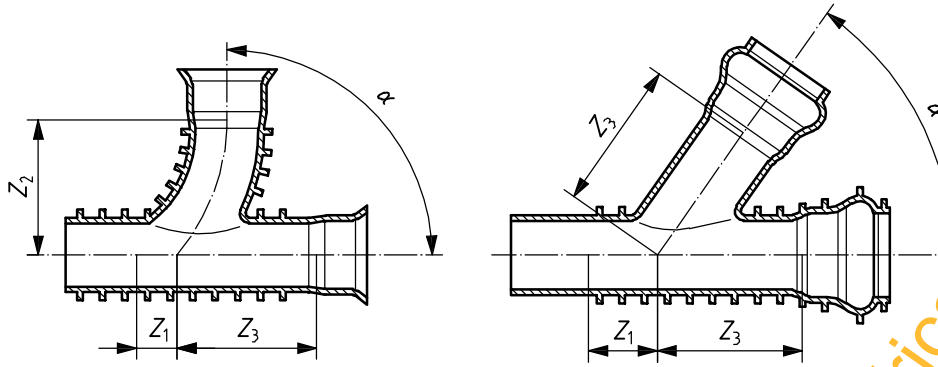
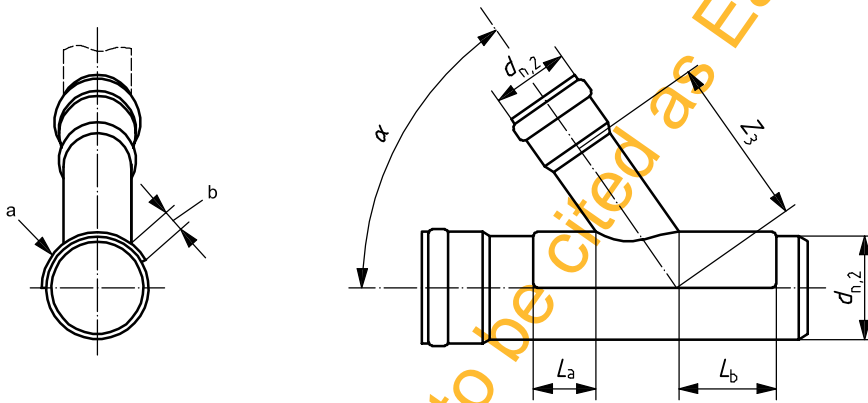

Figure 5 — Example of a swept entry and a straight branch



**Key**

- a  $d_{n1} < 315 \text{ mm}$ .
- b  $d_{n1} \geq 315 \text{ mm}$ .

Figure 6 — Example of a non-mechanical saddle

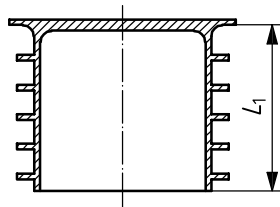

Figure 7 — Example of a plug

The minimum length,  $L_1$  of the spigots shall be such that it passes the ring seal by at least 10 mm.

## 8.2 Design length of fittings

The design length(s) (*Z*-lengths) of the fittings (see Figures 1 to 6) shall be declared by the manufacturer.

NOTE The design lengths (*Z*-lengths) are intended to assist in the design of moulds and are not intended to be used for quality control purposes; ISO 265-1 can be used as a guide.

## 9 Functional characteristics

In order to ensure good system performance, i.e. safe installation and proper functioning of the installed piping system, the components shall meet the test requirements specified in ISO 21138-2 or ISO 21138-3 as relevant.

The relation between the system performance and the tested characteristics is explained in Table 1.

Information about other functional characteristics is given in Annex B.

## 10 Relation between ring stiffness, installation technique and resulting deflection

Flexible pipes installed in the ground deflect during installation due to the forces exerted on them, as well as after installation due to further settlement of the soil. The amount of deflection reached after installation depends, to a great extent, on the quality of workmanship and, to a lesser extent, on the pipe stiffness.

The choice of nominal ring stiffness (SN) can be made based on the following existing reference situations:

- the same class of pipe used under acceptable similar or more severe conditions;
- the design graph and the structural design (see Annex C).

Table 1 — Relationship between system performance criteria and tested characteristics

System performance criterion	Tested characteristic	Test method/practice
System compatibility	Dimensions and tolerances	ISO 3126
Resistance to soil load	Ring stiffness — pipe Ring stiffness — fitting Ring flexibility Mechanical strength or flexibility of fabricated fitting Tensile strength of seam	ISO 9969 ISO 13967 (same nominal ring stiffness as pipe if same wall construction as pipe) EN 1446 EN 12256 EN 1979
Long term performance (durability)	Creep ratio	ISO 9967
Handling/robustness	Impact strength — pipe Impact strength — fitting Additional characteristics — cold climate UV resistance Tensile strength of seam	ISO 3127 EN 12061 ISO 11173 According to national practice EN 1979
Ability to hold fluid (leaktightness)	Dimensions and tolerances Tightness Long term performance of TPE seals Watertightness of fabricated fittings Tensile test of welded and fused joints Longitudinal reversion Tensile strength of seam	ISO 3126 EN 1277 EN 14741 EN 1053 EN 1979 ISO 2505 EN 1979
Identification	Colour	National preference
Cleaning	Roding Flushing — high volume, low pressure High pressure cleaning	According to national practice
Durability	UV resistance Vicat softening temperature Resistance to dichloromethane Resistance to internal pressure Resistance to heating – oven test Effect of heating Melt flow rate Thermal stability Density	According to national practice ISO 2507-1 and ISO 2507-2 ISO 9852 ISO 1167-1 and ISO 1167-2 ISO 12091 ISO 580 ISO 1133 ISO 11357-6 ISO 1183-1

## Annex A (informative)

### General material characteristics of PVC-U, PP and PE pipes and fittings

#### A.1 Material characteristics

The materials of pipes and fittings conforming to this part of ISO 21183 generally have the following characteristics. See Table A.1.

NOTE The values in Table A.1, whilst approximate, commonly suffice for design purposes. In instances where more accurate values are required, reference should be made to the pipe or fitting manufacturer.

Table A.1

Characteristic	Test method	PVC-U	PP	PE	Unit
Flexural modulus, $E_{(1 \text{ min})}$	ISO 178	3 100 to 3 500	1 250 to 1 900	1 000 to 1 200	MPa
Density	ISO 1183-1	1 400	900	950	kg·m <sup>-3</sup>
Coefficient of linear thermal expansion	ISO 11359-2	$8 \times 10^{-5}$	$14 \times 10^{-5}$	$17 \times 10^{-5}$	mm·mm <sup>-1</sup> ·K <sup>-1</sup>
Thermal conductivity		0,16	0,2	0,4 to 0,50	W·K <sup>-1</sup> ·m <sup>-1</sup>
Poisson's Ratio		0,37	0,4	0,4	
Specific heat		1 000		2 300 to 2 900	J·kg <sup>-1</sup> ·K <sup>-1</sup>

#### A.2 Chemical resistance

Piping systems conforming to this part of ISO 21138 are resistant to corrosion by water with a wide range of pH-values such as domestic waste water, surface water and ground water. If piping systems conforming to this part of ISO 21138 are to be used for chemically contaminated waste waters, such as industrial discharges, chemical and temperature resistance must be taken into account.

Guidance on the chemical resistance of PVC-U, PP and PE materials is given in ISO/TR 10358 and of rubber materials in ISO/TR 7620.

**Annex B**  
(informative)

**General performance characteristics of PVC-U, PP and PE  
pipes and fittings**

**B.1 Abrasion resistance**

Pipes and fittings conforming to this part of ISO 21138 are resistant to abrasion. For special circumstances, the abrasion can be determined from the test method given in EN 295-3.

**B.2 Hydraulic roughness**

The internal surfaces of pipes and fittings conforming to this part of ISO 21138 are hydraulically smooth. The design of joints and fittings ensures good hydraulic performances. For further information about hydraulic capacity of pipes and fittings conforming to this part of ISO 21138, refer to the manufacturer's instructions.

**B.3 Diametric deflection**

In normal installation conditions (well or moderate compaction in Annex C), the expected average deflection of the inside diameters of the pipes will be less than 8 %.

## Annex C (informative)

### Structural design

#### C.1 General

In general, structural design of a thermoplastics pipeline construction by applying analytical or numerical methods is not needed. Whether any calculated prediction of the pipe behaviour holds true in reality is strongly dependent on whether the installation conditions used for the calculation are the same as those used for the installation. Therefore, it is important that effort be put into controlling the input values by extensive soil surveys and monitoring of the installation. In many cases, practical and/or reference information, e.g. as listed in Annex A, is available and results in good prediction of the pipe performance.

#### C.2 Structural design based on a design graph

Designers first need to establish permitted deflections, average and maximum. (National requirements, product standards and this part of ISO 21138, etc. give guidance.)

Following the method described below fulfils the requirements of EN 1610:1997, 4.2.

An intensive study of the deflection history of pipes installed under different conditions up to 25 years ago has resulted in experience as presented in the design graph shown in Figure C.1.

For the deflection mentioned in the design graph, the strain will be far below the design limit, and does not need to be taken into account in the design.

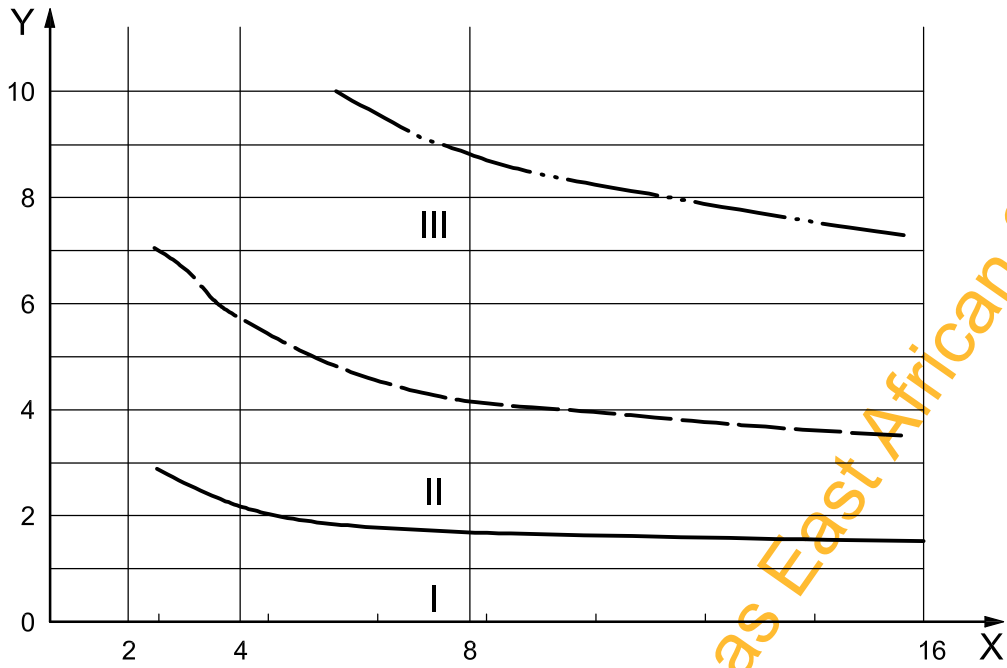

**Key**

X ring stiffness in kilopascals  
 Y pipe deflection in percent

- I "well" compaction
- II "moderate" compaction
- III "non-" compaction (not recommended)

**Figure C.1 — Design graph (long term pipe deflection (maximum values))**

The design graph is valid under the conditions in Table C.1.

Table C.1 — Validity of the design graph

Pipe system	Fulfilling requirements in ISO 8772, ISO 8773, ISO 4435, ISO 21138, Parts 1 to 3 as applicable
Installation depth	0,8 m to 6,0 m
Traffic loading	Included
Installation quality	<p><b>“Well” compaction (I)</b></p> <p>The embedment soil of a granular type is placed carefully in the haunching zone and compacted, after which the soil is placed in shifts of maximum 30 cm, after which each layer is compacted carefully. The pipe shall at least be covered by a layer of 15 cm. The trench is further filled with soil of any type and compacted. Typical values for the proctor density are above 94 %.</p> <p><b>“Moderate” compaction (II)</b></p> <p>The embedment soil of a granular type is placed in shifts of maximum 50 cm, after which each layer is compacted carefully. The pipe shall at least be covered by a layer of 15 cm. The trench is further filled with soil of any type and compacted. Typical values for the proctor density are in the range of 87 % to 94 %.</p> <p>Sheet piles should be removed before compaction, in accordance with the recommendations in EN 1610:1997. If, however, the sheet piles are removed after compaction one should realise that the “well” or “moderate” compaction level will be reduced to the “non-” compaction level (III).</p>
Additional	National rules may apply.

### C.3 Structural design based on design calculations

When structural design is required, e.g. in cases where no other information exists, then a method as defined in EN 1295-1 should be used. If input values for the pipes are required, the values given in Table A.1 are recommended.

Unless otherwise agreed between the specifier and the system owner it is recommended that, for reasons of serviceability, the calculated average deflection values do not exceed the values given in Table C.2.

Table C.2 — Recommended design deflection limits

Stiffness class SN	Average initial deflection	Average long term deflection
SN 2	5 %	8 %
SN 4, 8, 16	8 %	10 %

### C.4 Selection of fitting stiffness or class

Table C.3 — Minimum fitting classes recommended for use with structured-wall pipes

Pipe stiffness class	Minimum wall-thickness class of fittings according to			
	ISO 21138-2 and ISO 21138-3	ISO 8773	ISO 4435	ISO 8772
SN 2	SN 2	SDR 41	SDR 51	SDR 33
SN 4	SN 4	SDR 41	SDR 41	SDR 33
SN 8	SN 8	SDR 33	SDR 34	SDR 26
SN 16	SN 16	SDR 23,4	SDR 34	SDR 21

## Bibliography

- [1] ISO 178, *Plastics — Determination of flexural properties*
- [2] ISO 265-1, *Pipes and fittings of plastics materials — Fittings for domestic and industrial waste pipes — Basic dimensions: Metric series — Part 1: Unplasticized poly(vinyl chloride) (PVC-U)*
- [3] ISO/TR 7620, *Rubber materials — Chemical resistance*
- [4] ISO/TR 10358, *Plastics pipes and fittings — Combined chemical-resistance classification table*
- [5] ISO 11359-2, *Plastics — Thermomechanical analysis (TMA) — Part 2: Determination of coefficient of linear thermal expansion and glass transition temperature*
- [6] EN 295-3, *Vitrified clay pipes and fittings and pipe joints for drains and sewers — Part 3: Test methods*
- [7] EN 1295-1, *Structural design of buried pipelines under various conditions of loading — Part 1: General requirements*
- [8] EN 1610:1997, *Construction and testing of drains and sewers*
- [9] RAL 7037 and 8023 — HR Colour register (obtainable from national standards institutes)

*Draft for comments only — Not to be cited as East African Standard*

---

---

**ICS 23.040.20; 23.040.45; 91.140.80; 93.030**

Price based on 18 pages

*Draft for comments only — Not to be cited as East African Standard*