



EAST AFRICAN STANDARD

Thermoplastics piping systems for underground non-pressure applications — Test method for leaktightness of elastomeric sealing ring type joints

EAST AFRICAN COMMUNITY

Foreword

Development of the East African Standards has been necessitated by the need for harmonizing requirements governing quality of products and services in East Africa. It is envisaged that through harmonized standardization, trade barriers which are encountered when goods and services are exchanged within the Community will be removed.

In order to meet the above objectives, the EAC Partner States have enacted an East African Standardization, Quality Assurance, Metrology and Test Act, 2006 (EAC SQMT Act, 2006) to make provisions for ensuring standardization, quality assurance, metrology and testing of products produced or originating in a third country and traded in the Community in order to facilitate industrial development and trade as well as helping to protect the health and safety of society and the environment in the Community.

East African Standards are formulated in accordance with the procedures established by the East African Standards Committee. The East African Standards Committee is established under the provisions of Article 4 of the EAC SQMT Act, 2006. The Committee is composed of representatives of the National Standards Bodies in Partner States, together with the representatives from the private sectors and consumer organizations. Draft East African Standards are circulated to stakeholders through the National Standards Bodies in the Partner States. The comments received are discussed and incorporated before finalization of standards, in accordance with the procedures of the Community.

Article 15(1) of the EAC SQMT Act, 2006 provides that "Within six months of the declaration of an East African Standard, the Partner States shall adopt, without deviation from the approved text of the standard, the East African Standard as a national standard and withdraw any existing national standard with similar scope and purpose".

East African Standards are subject to review, to keep pace with technological advances. Users of the East African Standards are therefore expected to ensure that they always have the latest versions of the standards they are implementing.

© East African Community 2010 — All rights reserved*

East African Community

P O Box 1096

Arusha

Tanzania

Tel: 255 27 2504253/8

Fax: 255-27-2504481/2504255

E-Mail: eac@eachq.org

Web: www.each.int

* © 2010 EAC — All rights of exploitation in any form and by any means reserved worldwide for EAC Partner States' NSBs.

Introduction

In the preparation of this East African Standard, the following source was consulted extensively:

ISO 13259:2010, *Thermoplastics piping systems for underground non-pressure applications — Test method for leaktightness of elastomeric sealing ring type joints*

Assistance derived from this source and others inadvertently not mentioned is hereby acknowledged.

Draft for comments only — Not to be cited as East African Standard

**Thermoplastics piping systems for
underground non-pressure
applications — Test method for
leaktightness of elastomeric sealing ring
type joints**

*Systèmes de canalisations thermoplastiques pour applications
enterrées sans pression — Méthodes d'essai d'étanchéité des
assemblages à bague d'étanchéité en élastomère*



PDF disclaimer

This PDF file may contain embedded typefaces. In accordance with Adobe's licensing policy, this file may be printed or viewed but shall not be edited unless the typefaces which are embedded are licensed to and installed on the computer performing the editing. In downloading this file, parties accept therein the responsibility of not infringing Adobe's licensing policy. The ISO Central Secretariat accepts no liability in this area.

Adobe is a trademark of Adobe Systems Incorporated.

Details of the software products used to create this PDF file can be found in the General Info relative to the file; the PDF-creation parameters were optimized for printing. Every care has been taken to ensure that the file is suitable for use by ISO member bodies. In the unlikely event that a problem relating to it is found, please inform the Central Secretariat at the address given below.



COPYRIGHT PROTECTED DOCUMENT

© ISO 2010

All rights reserved. Unless otherwise specified, no part of this publication may be reproduced or utilized in any form or by any means, electronic or mechanical, including photocopying and microfilm, without permission in writing from either ISO at the address below or ISO's member body in the country of the requester.

ISO copyright office
Case postale 56 • CH-1211 Geneva 20
Tel. + 41 22 749 01 11
Fax + 41 22 749 09 47
E-mail copyright@iso.org
Web www.iso.org

Published in Switzerland

Foreword

ISO (the International Organization for Standardization) is a worldwide federation of national standards bodies (ISO member bodies). The work of preparing International Standards is normally carried out through ISO technical committees. Each member body interested in a subject for which a technical committee has been established has the right to be represented on that committee. International organizations, governmental and non-governmental, in liaison with ISO, also take part in the work. ISO collaborates closely with the International Electrotechnical Commission (IEC) on all matters of electrotechnical standardization.

International Standards are drafted in accordance with the rules given in the ISO/IEC Directives, Part 2.

The main task of technical committees is to prepare International Standards. Draft International Standards adopted by the technical committees are circulated to the member bodies for voting. Publication as an International Standard requires approval by at least 75 % of the member bodies casting a vote.

Attention is drawn to the possibility that some of the elements of this document may be the subject of patent rights. ISO shall not be held responsible for identifying any or all such patent rights.

ISO 13259 was prepared by Technical Committee ISO/TC 138, *Plastics pipes, fittings and valves for the transport of fluids*, Subcommittee SC 1, *Plastics pipes and fittings for soil, waste and drainage (including land drainage)*.

Draft for comments only — Not to be cited as East African Standard

Thermoplastics piping systems for underground non-pressure applications — Test method for leaktightness of elastomeric sealing ring type joints

1 Scope

This International Standard specifies three basic test pressures for determining the leaktightness of elastomeric sealing ring type joints for buried thermoplastics non-pressure piping systems.

Unless otherwise specified in the referring standard, the methods use the following pressures:

- p_1 : internal negative air pressure (partial vacuum);
- p_2 : low internal hydrostatic pressure;
- p_3 : higher internal hydrostatic pressure.

It also describes the following four conditions under which the test can be executed:

- a) A: without any additional diametric or angular deflection;
- b) B: with diametric deflection;
- c) C: with angular deflection;
- d) D: with simultaneous angular and diametric deflection.

These conditions can be applied individually or in combination. The applicable selection of the method(s) and the condition(s) should be specified in the referring standard.

2 Principle

A test piece assembled from pipes and/or fittings is subjected to a specific initial internal negative air pressure, p_1 followed by a low specific initial internal hydrostatic pressure, p_2 , and a higher internal hydrostatic pressure, p_3 .

During testing, the joint may be subjected to diametric or angular deflection(s). The referring product standard shall specify which of the test pressures and deflection conditions shall be carried out.

Each pressure is maintained for a specific period, during which time the joint is monitored for leakage (see Clause 6).

It is assumed that the following test parameters are set by the referring standard:

- a) the test pressure(s), p_1 [see item d) of 6.1], p_2 [see item f) of 6.1] and p_3 [see item g) of 6.1], as applicable, and the percentage of loss of partial vacuum [see item d) of 6.1];
- b) the required diametric and angular deflections and their combination with each other and/or the test pressure(s).

3 Apparatus

3.1 General

The apparatus shall consist of a jig or any other arrangement capable of:

- a) applying the specified diametric and angular deflection;
- b) applying the specified test pressure(s), positive or negative;
- c) maintaining the test assembly in the required position throughout the test;
- d) resisting the forces resulting from the mass of the water in the test assembly and from the applied hydrostatic test pressure(s) during the test period.

The apparatus shall not otherwise support the joint against the internal test pressure.

A typical arrangement, allowing angular and diametric deflection, is shown in Figure 1.

3.2 Apparatus

The apparatus shall include the following items, which all shall be capable of resisting the forces and pressures generated during the test.

3.2.1 End sealing devices, having a size and using a sealing method appropriate to seal the non-jointed ends of the test assembly. The devices shall be restrained in a manner that does not exert longitudinal forces on the joint at positive pressures.

3.2.2 Hydrostatic pressure source, connected to one of the sealing devices, or to the test piece, and capable of applying and maintaining the specified pressure [see items f) and g) of 6.1].

3.2.3 Negative air pressure source, connected to one of the sealing devices or to the test piece, and capable of applying and maintaining the specified internal negative air pressure for the specified time [see item d) of 6.1].

3.2.4 Arrangement, capable of venting air from the assembly.

3.2.5 Pressure measuring devices, capable of checking conformity to the specified test pressure [(see items d), f) and g) of 6.1].

When testing with diametric deflection is required, the items in 3.2.6 and 3.2.7 shall also be included.

3.2.6 Mechanical or hydraulic device, capable of applying the necessary diametric deflection to the spigot [see item b) of 6.1] and acting on a beam which is free to move in the vertical plane square to the axis of the pipe. For pipes with a diameter equal to or greater than 400 mm, each beam can be elliptically shaped to suit the expected shape of the pipe when deflected as required, see Figure 4. The length of the beam or the curved part of the beam shall be greater than the contact area with the deflected spigot.

The following width, b_1 (see Figure 1), shall depend upon the external diameter, d_e , of the pipe:

- $b_1 = 100$ mm for $d_e \leq 710$ mm;
- $b_1 = 150$ mm for $710 \text{ mm} < d_e \leq 1\,000$ mm;
- $b_1 = 200$ mm for $d_e > 1\,000$ mm.

3.2.7 Mechanical or hydraulic device, capable of applying the necessary diametric deflection to the socket [see item b) of 6.1] and acting on a beam which is free to move in the vertical plane square to the axis of the socket. The length of the beam or the curved part of the beam shall be greater than the contact area with the deflected socket.

For pipes with a diameter equal to or greater than 400 mm, each beam may be elliptically shaped to suit the expected shape of the socket when deflected as required, see Figure 4.

The following width, b_2 , shall depend upon the external diameter, d_e , of the pipe:

- $b_2 = 30$ mm for $d_e \leq 110$ mm;
- $b_2 = 40$ mm for $110 \text{ mm} < d_e \leq 315$ mm;
- $b_2 = 60$ mm for $d_e > 315$ mm.

When there is a risk that the stiffening elements (profiles) of a structured wall pipe or socket will deflect more than 0,1 times the profile height, the clamps shall be modified such that they come into contact with the pipe wall between the profiles when the profile is deflected to between 0,9 times and 0,95 times the profile height (see Figure 2).

Such modifications shall be made from wood or less flexible materials.

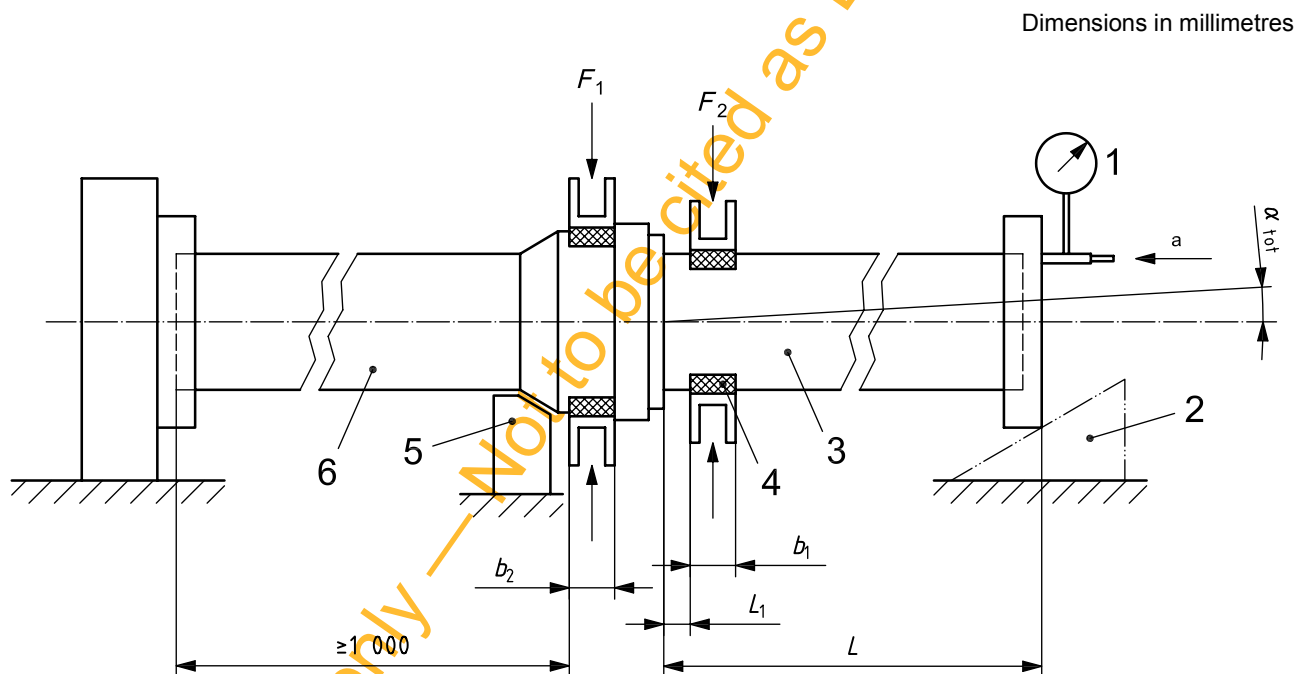

Key

- 1 vacuum or pressure gauge
- 2 adjustable support
- 3 pipe or fitting with spigot end
- 4 elliptical beam, when applicable
- 5 socket support
- 6 pipe or fitting with socket
- α_{tot} angular deflection applied
- b_1, b_2 width of clamp (see 3.2.6 and 3.2.7)
- F_1, F_2 compressive force
- L length of spigot-ended pipe or fitting, where $L \geq d_e$ or $L \geq 1\,000$, whichever is the greater, in millimetres
- L_1 distance between socket mouth and clamp

^a Connection to pressure source.

Figure 1 — Typical arrangement for applying diametric distortion and angular deflection

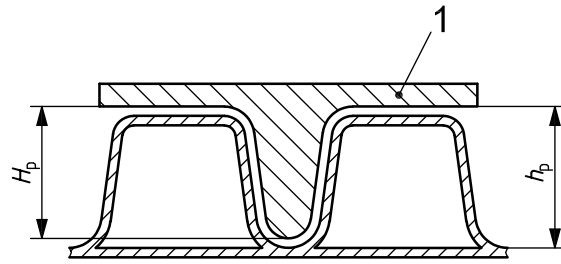

Key

- 1 modified loading plate
- h_p construction height
- H_p profile height of the loading plate; $0,9h_p \leq H_p \leq 0,95h_p$

Figure 2 — Example of modified loading plate

4 Test pieces

The test piece shall comprise an assembly of (a) pipe section(s) and/or fitting(s) including at least one elastomeric sealing ring joint.

The joint to be tested shall be assembled in accordance with the manufacturer's instructions, where available.

The length of the test pieces in pipe form shall be as specified in Figure 1.

The same test assembly shall be used for the entire specified test regime.

NOTE To reduce the volume of water needed a sealed pipe or mandrel can be located within the test piece provided it is 100 % tight to the test pressures applied, and is not of a shape that can provide support against possible deformation during the test.

When a fitting or any other ancillary component is to be tested, the appropriate end of the test piece shown in Figure 1 is to be replaced by that component.

The component is fixed to the test rig and plugged in its open end(s) as appropriate for its design.

5 Test temperature

When testing with internal hydrostatic pressure using water, the test temperature shall be $(19 \pm 9) ^\circ\text{C}$.

When testing with internal partial vacuum, the test temperature shall be in the range of $(23 \pm 5) ^\circ\text{C}$ and the temperature variation shall not exceed $2 ^\circ\text{C}$ during the testing.

6 Procedure

6.1 General

Carry out the following procedures at the specified temperatures.

- a) Mount the test piece with sealed ends in the apparatus.
- b) When applicable, apply the specified movement of the loading beams for diametric deflection of the spigot and/or socket end(s), as described in 6.2.

- c) When applicable, apply the specified angular deflection to the joint. Unless otherwise specified in the referring standard, the applied angular deflection, α , shall be the following:

$$\alpha = 2^\circ \quad \text{for } d_n \leq 315 \text{ mm};$$

$$\alpha = 1,5^\circ \quad \text{for } 315 \text{ mm} < d_n \leq 630 \text{ mm};$$

$$\alpha = 1^\circ \quad \text{for } d_n > 630 \text{ mm}.$$

Tolerance on all deflections: $\alpha_0^{+0,2}$.

If a socket is designed to take up an angular deflection, β , the total angular deflection shall be the sum of the design angle β , as declared by the manufacturer, and α .

Maintain these settings throughout the testing.

- d) When applicable, apply the specified negative air pressure (partial vacuum), p_1 , gradually over a period of not less than 5 min. Unless otherwise specified in the referring standard, p_1 shall be $-0,3 \text{ bar}^1) \pm 5 \%$.

Maintain the negative air pressure for a period of not less than 5 min, in order to let the test assembly stabilize.

Close the connection between the test piece and the negative air pressure source. Measure and record the internal negative pressure.

After 15 min, measure and record the internal negative pressure again.

Calculate the loss of partial vacuum and record whether or not it exceeds the specified percentage of p_1 . Unless otherwise specified in the referring standard, the percentage shall be 10 %.

- e) When applicable, fill the test assembly with water while bleeding off the air. To ensure temperature equalization, leave it for no less than 5 min for pipes of nominal diameter, d_n , less than 400 mm and no less than 15 min for larger sizes.
- f) When applicable, raise the hydrostatic pressure gradually over a period of not less than 5 min to the specified test pressure, p_2 , and maintain that pressure for at least 15 min, monitor the test piece for, and record any leakage. Unless otherwise specified in the referring standard, p_2 shall be $0,05 \text{ bar} \pm 10 \%$.
- g) When applicable, raise the hydrostatic pressure gradually over a period of no less than 5 min to the specified test pressure, p_3 , and maintain that pressure for at least 15 min, monitor the test piece for, and record any leakage. Unless otherwise specified in the referring standard, p_3 shall be between $0,5 \text{ bar}$ and $(0,5 \text{ bar} + 10 \%)$.
- h) If applicable, start from b) with another set of required test parameters after an appropriate rest period which, in case of dispute, shall be at least 24 h.

1) 1 bar = 0,1 MPa = 10^5 Pa; 1 MPa = 1 N/mm².

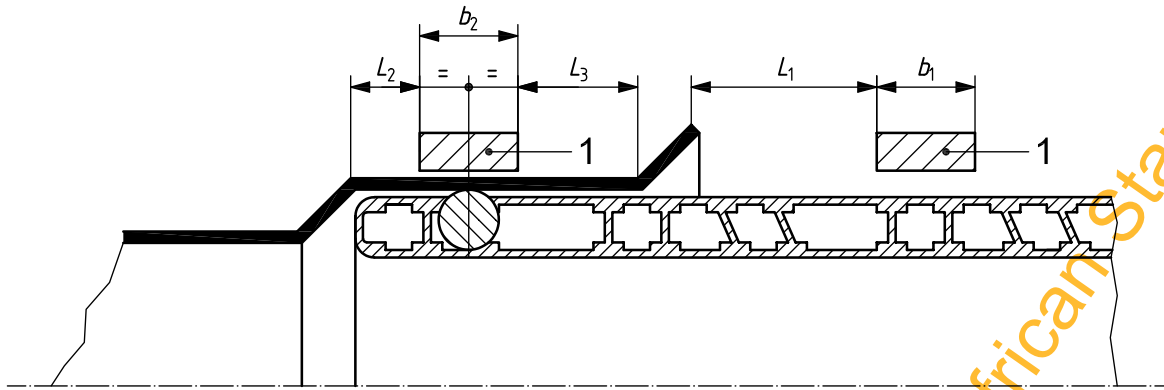

Key
1 beam

Figure 3 — Positioning of beam for a sealing ring in an example of a spigot

6.2 Procedure for applying diametric deflection to spigot and socket

Using the mechanical or hydraulic device (see 3.2.6 and 3.2.7), apply the necessary compressive forces, F_1 and F_2 (see Figure 1), to the spigot end of the pipe and the socket of the pipe or fitting in such a way that the distance between the beams, l_{sp} and l_{so} , are as calculated below.

- a) Calculate the distance between the beams when the socket and/or spigot is deflected using Equations (1) and (2):

$$l_{sp} = d_{em} \times (1 - X/100) \tag{1}$$

$$l_{so} = d_{em,so} - (d_{em} \times Y/100) \tag{2}$$

where

- l_{sp} is the distance between the plates for deflecting the spigot;
- l_{so} is the distance between the plates for deflecting the socket;
- d_{em} is the mean outside diameter of the spigot end;
- $d_{em,so}$ is the mean outside diameter of the socket;
- X is the absolute value of the specified nominal spigot deflection;
- Y is the absolute value of the specified nominal socket deflection.

Unless otherwise specified in the referring standard, X shall be 10 % and Y shall be 5 % (see Figure 4).

EXAMPLE $d_{em} = 1\,000$ mm; $d_{em,so} = 1\,100$ mm; $X = 10$ %; $Y = 5$ %:

$$l_{sp} = 1\,000 \times (1 - 10/100) = 900 \text{ mm};$$

$$l_{so} = 1\,100 - (1\,000 \times 5/100) = 1\,045 \text{ mm}.$$

- b) Position the spigot deflection clamps such that the distance to the mouth of the socket, L_1 , when the force is applied, is between $0,14d_e$ and $0,15d_e$ or (100 ± 5) mm, whichever is the greater. In case of structured wall pipes where the profiles are positioned further away from the socket mouth, the clamps shall be modified in order to apply the force to the spigot at the specified distance.

- c) For joints with the sealing ring positioned in the socket, the socket diameter deflection beams shall be positioned next to the sealing ring groove, as shown in Figure 1. For joints with the sealing ring(s) positioned on the spigot end of the pipe, the socket diameter deflection beams shall be positioned such that the axis of the beam is aligned with the centreline of the sealing ring profile(s). If the sealing ring(s) are positioned such that the distance from the edge of the beams to the end of the socket, L_2 as shown in Figure 3 is less than 25 mm, the edge of the beams shall be located such that L_3 is at least 25 mm and, if possible L_2 is also at least 25 mm.
- d) Apply the forces needed to move the spigot and socket diametric deflection devices to the calculated levels. If by deflection of the spigot, the socket is deflected more than calculated, this shall not be deemed as a failure and the test shall be carried out under these conditions.
- e) Continue with item c) of 6.1.

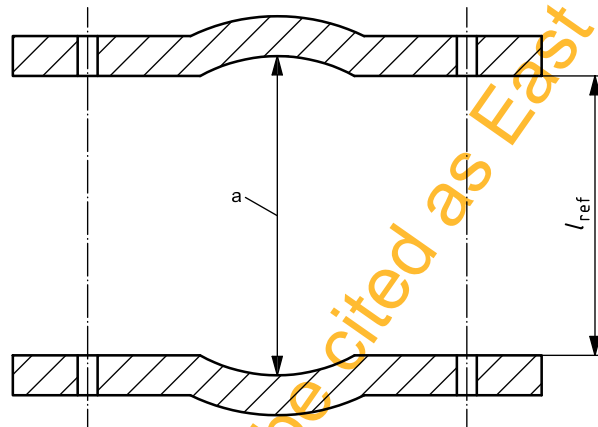

Key

l_{ref} reference distance, e.g. for checking conformity to l_{sp} or l_{so}

^a l_{sp} or l_{so} , as calculated in accordance with item 6.2 a).

Figure 4 — Example of diametric deflection device

7 Test report

The test report shall at least include the following information:

- a) a reference to this International Standard, i.e. ISO 13259, and the referring standard;
- b) the identity of the components (e.g. fittings, pipes, seals) comprising the joints under test;
- c) the ambient temperature, in degrees Celsius;
- d) for each of the test pressures used:
 - 1) the test pressure(s), in bars;
 - 2) the period of time under pressure, in minutes;
 - 3) the initial vacuum, the vacuum after 15 min and the calculated loss of vacuum in percentage for the negative air pressure test;
 - 4) report of any leakage for the hydrostatic pressure test condition(s), or otherwise a statement that the joint(s) did not leak;

- e) if applicable:
- 1) the diametric distortion(s) of the pipe and the socket;
 - 2) the distance, L_1 , between the mouth of the socket and the nearest face of the spigot deflection beams, in millimetres;
 - 3) the position of the socket deflection beams;
 - 4) the angular deflection applied;
- f) any factor which could have affected the results, such as any incident or any operating details not specified in this International Standard;
- g) the date of test.

Draft for comments only — Not to be cited as East African Standard

Draft for comments only — Not to be cited as East African Standard

Draft for comments only — Not to be cited as East African Standard