

INTERNATIONAL
STANDARD

ISO
8283-1

For information only — Not to be cited as East African Standard



Reference number
ISO 8283-1:1991(E)

Foreword

ISO (the International Organization for Standardization) is a worldwide federation of national standards bodies (ISO member bodies). The work of preparing International Standards is normally carried out through ISO technical committees. Each member body interested in a subject for which a technical committee has been established has the right to be represented on that committee. International organizations, governmental and non-governmental, in liaison with ISO, also take part in the work. ISO collaborates closely with the International Electrotechnical Commission (IEC) on all matters of electrotechnical standardization.

Draft International Standards adopted by the technical committees are circulated to the member bodies for voting. Publication as an International Standard requires approval by at least 75 % of the member bodies casting a vote.

International Standard ISO 8283-1 was prepared by Technical Committee ISO/TC 138, *Plastics pipes, fittings and valves for the transport of fluids*.

ISO 8283 consists of the following parts, under the general title *Plastics pipes and fittings — Dimensions of sockets and spigots for discharge systems inside buildings*:

- *Part 1: Unplasticized poly(vinyl chloride) (PVC-U) and chlorinated poly(vinyl chloride) (PVC-C)*
- *Part 2: High-density polyethylene (PE-HD)*
- *Part 3: Polypropylene (PP)*
- *Part 4: Acrylonitrile/butadiene/styrene (ABS)*

Annexes A and B form an integral part of this part of ISO 8283.

© ISO 1991

All rights reserved. No part of this publication may be reproduced or utilized in any form or by any means, electronic or mechanical, including photocopying and microfilm, without permission in writing from the publisher.

International Organization for Standardization
Case Postale 56 • CH-1211 Genève 20 • Switzerland

Printed in Switzerland

Introduction

The socket design appropriate for a particular application should be chosen according to the type of system and jointing techniques to be used. Various socket designs are specified in this part of ISO 8283. They may be selected for use in accordance with the requirements of relevant national standards and codes of practice, which give information on the choice of the type of system and jointing techniques to be used.

This page intentionally left blank

Plastics pipes and fittings — Dimensions of sockets and spigots for discharge systems inside buildings —

Part 1:

Unplasticized poly(vinyl chloride) (PVC-U) and chlorinated poly(vinyl chloride) (PVC-C)

1 Scope

This part of ISO 8283 establishes a classification and designation system for sockets and specifies the design formulae and the derived dimensions, together with tolerances, of these sockets and of spigots for joints of unplasticized poly(vinyl chloride) (PVC-U) and chlorinated poly(vinyl chloride) (PVC-C) fittings and for integral sockets of PVC-U and PVC-C pipes used in discharge systems inside buildings.

2 Classification and designation of sockets

The sockets shall be classified according to whether they are ring-seal sockets or solvent cement sockets into the following types.

2.1 Ring-seal sockets

2.1.1 Type S (short) for use as an expansion joint system where the length of pipe does not exceed 2 m. When these sockets form part of a fixed joint system (i.e. systems which do not in themselves allow for expansion and contraction) they shall be used in conjunction with a type L (long) socket as specified in this part of ISO 8283.

Type S sockets are further classified as normal configuration (N), for use only as a ring-seal socket, or as dual-purpose configuration (DP), for use either as a ring-seal socket or as a solvent cement socket.

2.1.2 Type M (medium) for use as an expansion joint system where, for nominal outside pipe diameters, D , up to 90 mm, the length of the pipe does not exceed 3 m, and for nominal outside pipe diameters greater than 90 mm the length of the pipe does not exceed 4 m. When these sockets form part of a fixed joint system (i.e. systems which do not in themselves allow for expansion and contraction), they shall be used in conjunction with a type L (long) socket as specified in this part of ISO 8283.

Type M sockets are further classified as normal configuration (N), for use only as a ring-seal socket, or as dual-purpose configuration (DP), for use either as a ring-seal socket or as a solvent cement socket.

2.1.3 Type L (long) for use as an expansion joint in fixed joint systems, i.e. systems which do not allow for expansion and contraction whether jointed by ring seal or solvent cement, or for use with type S and type M sockets where the length of pipe exceeds the given maximum for those types.

2.2 Solvent cement sockets

2.2.1 Type CS (short) for use where jointing is carried out by an approved manufacturer under controlled conditions.

Type CS sockets are available in two series: series X for interference fit joints and series Y where gap-filling solvent cements shall be used.

2.2.2 Type CL (long) for use where jointing is not carried out by an approved manufacturer under controlled conditions. Type CL sockets are available in two series: series X for interference fit joints and series Y where gap-filling solvent cements shall be used.

3 Ring-seal sockets and spigots (normal and dual-purpose)

3.1 General

These sockets can accommodate expansion and contraction in any of the joint systems given in clause 2 with the exception of the case where dual-purpose joints are used with solvent cement.

3.2 Ring-seal grooves

A selection of typical ring-seal groove designs is shown in figure 1 and figure 2 and the positions of measurement of specified dimensions are indicated. The design of the groove is not restricted to those illustrated.

3.3 Seal-ring retaining components

Seal-ring retaining components may be manufactured in plastics materials other than PVC-U and PVC-C.

3.4 Dimensions

3.4.1 General

The rules used for the calculation of the dimensions indicated in figure 1 and figure 2 are specified in annex A.

The actual values derived from the rules and additional non-calculated dimensions are specified in

table 1, table 2 and table 3. The calculated values have been rounded up to the nearest 0,1 mm for diameters and rounded to the nearest 1 mm for other dimensions.

The nominal outside diameters have been selected from ISO 161-1¹⁾ and those given in parentheses in table 1, table 2 and table 3 are non-preferred.

3.4.2 Dimension *B*

There shall be no requirement on dimension *B* where the seal ring is firmly retained in the groove.

4 Solvent cement sockets and spigots

4.1 General

Joints made using solvent cement sockets are rigid and do not allow for changes in length of a pipeline due to temperature variations. They are only intended for use in conjunction with a joint which accommodates expansion and contraction (see 2.1.1, 2.1.2 and 2.1.3).

4.2 Dimensions

The rules used for the calculation of the dimensions indicated in figure 3 are specified in annex B.

The actual values derived from these rules are specified in table 4 and table 5. Calculated values have been rounded up to the next 0,1 mm for diameters and rounded to the nearest 1 mm for other dimensions.

The nominal outside diameters have been selected from ISO 161-1 and those given in parentheses in table 4 and table 5 are non-preferred.

Within the tolerances necessary for manufacturing, solvent cement sockets should be approximately cylindrical.

1) ISO 161-1:1978, *Thermoplastics pipes for the transport of fluids — Nominal outside diameters and nominal pressures — Part 1: Metric series.*

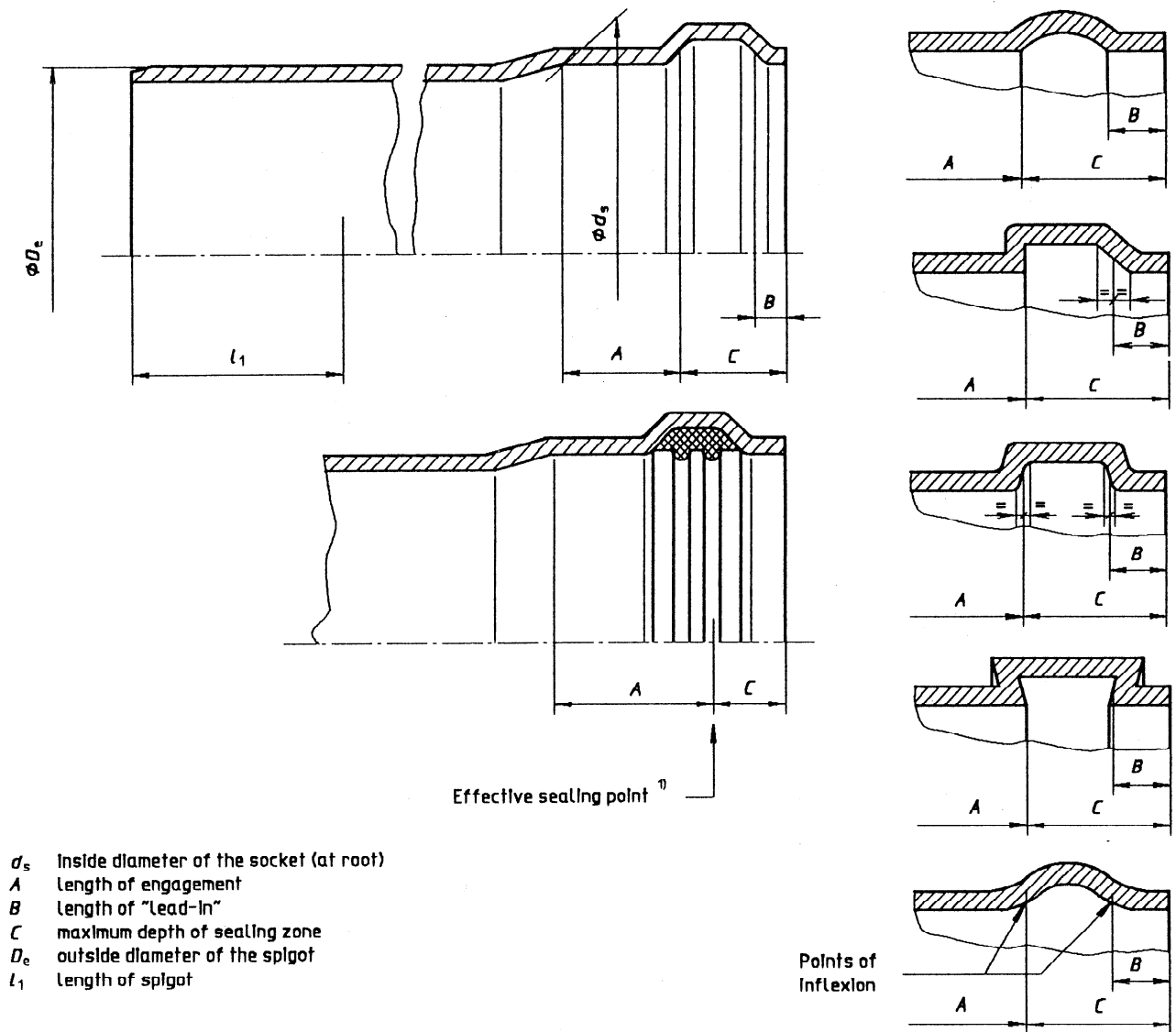
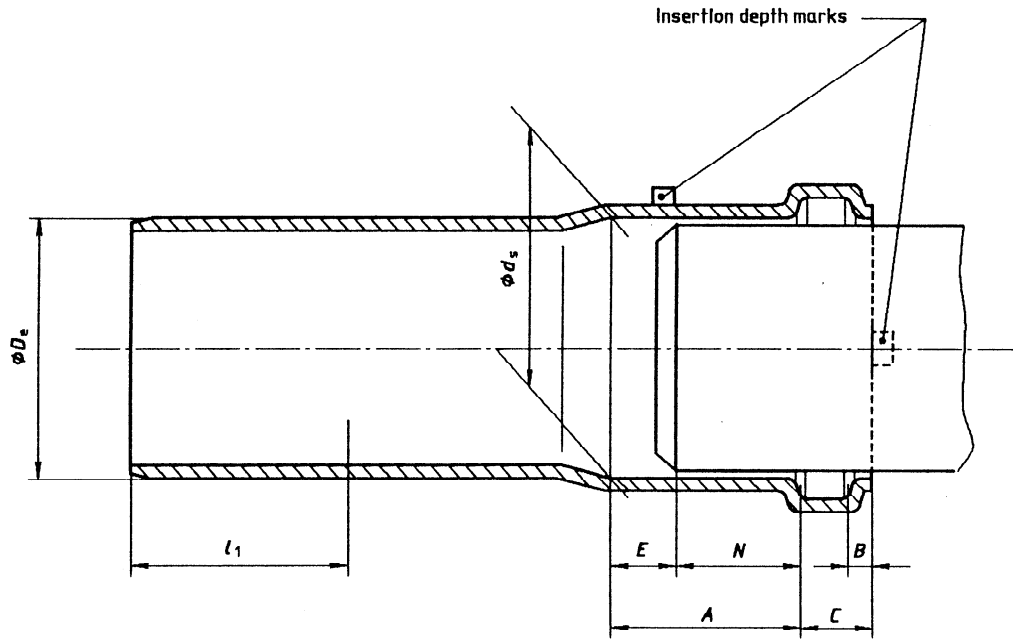
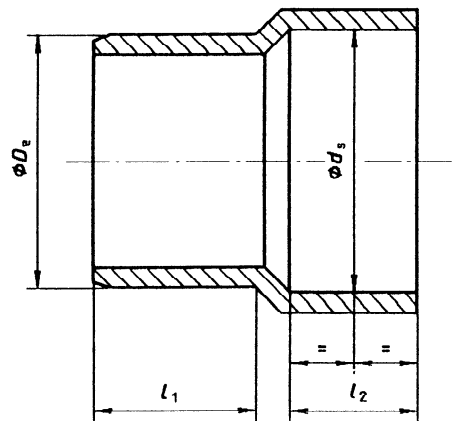

Figure 1 — Location of points of measurement for type S and type M sockets and spigots, normal and dual-purpose



- d_s Inside diameter of the socket (at root)
- A Length of engagement
- B Length of "Lead-In"
- C maximum depth of sealing zone
- E expansion gap
- N effective insertion depth
- l_1 length of spigot
- D_s outside diameter of the spigot

Figure 2 — Location of points of measurement for type L sockets and spigots



- d_s Inside diameter of the socket
- l_2 length of socket
- D_s outside diameter of the spigot
- l_1 length of spigot ($> l_2$)

Figure 3 — Location of points of measurement for solvent cement sockets and spigots

Table 1 — Dimensions of ring-seal sockets and related spigots, type S, normal and dual-purpose

Dimensions in millimetres

Nominal outside diameter <i>D</i>	<i>D_e</i>		<i>d_s</i>		<i>A</i>	<i>B</i>	<i>C</i>	<i>l₁</i>
	min.	max.	min.	max. 1)	min.	min.	max.	min.
(32)	32,0	32,3	32,4	32,7	16	5	18	34
40	40,0	40,3	40,4	40,7	18	5	18	36
50	50,0	50,3	50,4	50,7	20	5	18	38
(63)	63,0	63,3	63,4	63,8	23	5	18	41
75	75,0	75,3	75,4	75,8	25	5	20	43
90	90,0	90,3	90,4	90,8	28	5	23	46
110	110,0	110,4	110,5	110,9	32	6	26	54
125	125,0	125,4	125,5	126,0	35	7	28	60
160	160,0	160,5	160,6	161,1	42	9	32	74
200	200,0	200,6	200,7	201,2	50	12	40	90

1) Required for dual-purpose sockets only which, when used with solvent cement, are only suitable for use where jointing is carried out by an approved manufacturer under controlled conditions.

Table 2 — Dimensions of ring-seal sockets and related spigots, type M, normal and dual-purpose

Dimensions in millimetres

Nominal outside diameter <i>D</i>	<i>D_e</i>		<i>d_s</i>		<i>A</i>	<i>B</i>	<i>C</i>	<i>l₁</i>
	min.	max.	min.	max. 1)	min.	min.	max.	min.
(32)	32,0	32,3	32,4	32,7	24	5	18	42
40	40,0	40,3	40,4	40,7	26	5	18	44
50	50,0	50,3	50,4	50,7	28	5	18	46
(63)	63,0	63,3	63,4	63,8	31	5	18	49
75	75,0	75,3	75,4	75,8	33	5	20	51
90	90,0	90,3	90,4	90,8	36	5	23	56
110	110,0	110,4	110,5	110,9	40	6	26	62
125	125,0	125,4	125,5	126,0	43	7	28	68
160	160,0	160,5	160,6	161,1	50	9	32	82
200	200,0	200,6	200,7	201,2	58	12	40	98

1) Required for dual-purpose sockets only.

Table 3 — Dimensions of ring-seal sockets and related spigots, type L

Dimensions in millimetres

Nominal outside diameter <i>D</i>	<i>D_e</i>		<i>d_s</i>	<i>A</i>	<i>B</i>	<i>C</i>	<i>E</i>	<i>N</i>	<i>l₁</i>
	min.	max.	min.	min.	min.	max.	min.	min.	min.
(32)	32,0	32,3	32,4		5	18			35
40	40,0	40,3	40,4		5	18			36
50	50,0	50,3	50,4		5	18			38
(63)	63,0	63,3	63,4		5	18			41
75	75,0	75,3	75,4	65	5	20	20	45	43
90	90,0	90,3	90,4		5	23			46
110	110,0	110,4	110,5		6	26			54
125	125,0	125,4	125,5		7	28			60
160	160,0	160,5	160,6		9	32			74
200	200,0	200,6	200,7		12	40			90

Table 4 — Dimensions of solvent cement sockets and spigots, type CS

Dimensions in millimetres

Nominal outside diameter <i>D</i>	<i>D_e</i>		<i>d_s</i> 1)		<i>d_s</i> 2)		<i>l₁</i>	<i>l₂</i>
	min.	max.	min.	max.	min.	max.	min.	min.
(32)	32,0	32,3	32,1	32,4	32,4	32,7	17	
40	40,0	40,3	40,1	40,4	40,4	40,7	18	
50	50,0	50,3	50,1	50,4	50,4	50,7	20	
(63)	63,0	63,3	63,1	63,4	63,4	63,8	23	
75	75,0	75,3	75,1	75,4	75,4	75,8	25	
90	90,0	90,3	90,1	90,4	90,4	90,8	28	
110	110,0	110,4	110,2	110,5	110,5	110,9	32	
125	125,0	125,4	125,2	125,5	125,5	126,0	35	
160	160,0	160,5	160,2	160,6	160,6	161,1	42	
200	200,0	200,6	200,2	200,7	200,7	201,2	50	

1) The absolute limits for the value of any inside diameter (also called the tolerance on ovality) shall be determined in accordance with the condition

$$d_{s,max} - d_{s,min} \leq 0,011D_e$$

For sockets for which the ratio e_2/D_e (where e_2 is the wall thickness, in millimetres, of the sockets) is smaller than 0,035 there is no requirement to be met in respect of this tolerance.

2) Series X and Y represent two different sets of internal diameter tolerances; in the case of series Y it is important that a suitable gap-filling solvent cement be used.

Table 5 — Dimensions of solvent cement sockets and spigots, type CL

Dimensions in millimetres

Nominal outside diameter <i>D</i>	<i>D_e</i>		<i>d_s</i> ¹⁾				<i>l</i> ₁	<i>l</i> ₂
	min.	max.	Series X ²⁾		Series Y ²⁾			
(32)	32,0	32,3	32,1	32,4	32,4	32,7	23	
40	40,0	40,3	40,1	40,4	40,4	40,7	26	
50	50,0	50,3	50,1	50,4	50,4	50,7	30	
(63)	63,0	63,3	63,1	63,5	63,4	63,8	36	
75	75,0	75,3	75,1	75,5	75,4	75,8	40	
90	90,0	90,3	90,1	90,5	90,4	90,8	46	
110	110,0	110,4	110,2	110,6	110,5	110,9	48	
125	125,0	125,4	125,2	125,6	125,5	126,0	51	
160	160,0	160,5	160,2	160,7	160,6	161,1	58	
200	200,0	200,6	200,2	200,8	200,7	201,2	66	

1) The absolute limits for the value of any inside diameter (also called the tolerance on ovality) shall be determined in accordance with the condition

$$d_{s,max} - d_{s,min} \leq 0,011D_e$$

For sockets for which the ratio e_2/D_e (where e_2 is the wall thickness, in millimetres, of the sockets) is smaller than 0,035 there is no requirement to be met in respect of this tolerance.

2) Series X and Y represent two different sets of internal diameter tolerances; in the case of series Y it is important that a suitable gap-filling solvent cement be used.

Annex A (normative)

Ring-seal design calculations

Table A.1 — Rules for the calculation of the dimensions of ring-seal sockets, type S, normal and dual-purpose

Dimensions in millimetres

Nominal outside diameter ¹⁾ <i>D</i>	<i>D_e</i>		<i>d_s</i>		<i>A</i> min.
	min.	max.	min.	max. ²⁾	
(32) 40 50 (63) 75 90 110 125 160 200	32,0 40,0 50,0 63,0 75,0 90,0 110,0 125,0 160,0 200,0	$D_{e,min} + 0,3$	$D_{e,max} + 0,1$	$d_{s,min} + 0,4$	$0,2 D_{e,min} + 10$
		$1,003 D_{e,min}$		$d_{s,min} + 0,5$	
1) The values given in parentheses are non-preferred. 2) Required for dual-purpose sockets only, which when used with solvent cement are only suitable for use where jointing is carried out by an approved manufacturer under controlled conditions.					

Table A.2 — Rules for the calculation of the dimensions of ring-seal sockets, type M, normal and dual-purpose

Dimensions in millimetres

Nominal outside diameter ¹⁾ <i>D</i>	<i>D_e</i>		<i>d_s</i>		<i>A</i> min.
	min.	max.	min.	max. ²⁾	
(32) 40 50 (63) 75 90 110 125 160 200	32,0 40,0 50,0 63,0 75,0 90,0 110,0 125,0 160,0 200,0	$D_{e,min} + 0,3$	$D_{e,max} + 0,1$	$d_{s,min} + 0,4$	$0,2 D_{e,min} + 18$
		$1,003 D_{e,min}$		$d_{s,min} + 0,5$	
1) The values given in parentheses are non-preferred. 2) Required for dual-purpose sockets only.					

Annex B (normative)

Solvent cement design calculations

Table B.1 — Rules for the calculation of the dimensions of solvent cement sockets and spigots, type CS

Dimensions in millimetres

Nominal outside diameter ¹⁾ <i>D</i>	<i>D_e</i>		Series X ²⁾		<i>d_s</i>	Series Y ²⁾		<i>l₂</i>	<i>l₁</i>
	min.	max.	min.	max.		min.	max.		
(32) 40 50 (63) 75 90 110 125 160 200	32,0 40,0 50,0 63,0 75,0 90,0 110,0 125,0 160,0 200,0	$D_{e,min} + 0,3$	$D_{e,min} + 0,1$	$D_{e,max} + 0,1$	$D_{e,max} + 0,1$	$d_{s,min} + 0,3$	$0,2 D_{e,min} + 10$	$\geq l_2$	
	$d_{s,min} + 0,4$								
	$1,003 D_{e,min}$	$D_{e,min} + 0,2$	$d_{s,min} + 0,5$						

1) The values given in parentheses are non-preferred.

2) Series X and Y represent two different sets of internal diameter tolerances; in the case of series Y it is important that a suitable gap-filling solvent cement be used.

Table B.2 — Rules for the calculation of the dimensions of solvent cement sockets and spigots, type CL

Dimensions in millimetres

Nominal outside diameter ¹⁾ <i>D</i>	<i>D_e</i>		Series X ²⁾		<i>d_s</i>	Series Y ²⁾		<i>l₂</i>	<i>l₁</i>
	min.	max.	min.	max.		min.	max.		
(32) 40 50 (63) 75 90 110 125 160 200	32,0 40,0 50,0 63,0 75,0 90,0 110,0 125,0 160,0 200,0	$D_{e,min} + 0,3$	$D_{e,min} + 0,1$	$D_{e,max} + 0,1$	$D_{e,max} + 0,1$	$d_{s,min} + 0,3$	$0,4 D_{e,min} + 10$	$\geq l_2$	
	$D_{e,max} + 0,2$			$d_{s,min} + 0,4$					
	$1,003 D_{e,min}$	$D_{e,min} + 0,2$	$d_{s,min} + 0,5$	$0,2 D_{e,min} + 26$					

1) The values given in parentheses are non-preferred.

2) Series X and Y represent two different sets of internal diameter tolerances; in the case of series Y it is important that a suitable gap-filling solvent cement be used.

This page intentionally left blank

This page intentionally left blank

UDC 621.643.413-036.743.22:696.122

Descriptors: buildings, drainage, plastics products, unplasticized polyvinyl chloride, chlorinated polyvinyl chloride, pipe fittings, spigot-and-socket joints, pipe sockets, dimensions.

Price based on 9 pages

Draft for comments only — Not to be cited as East African Standard