



EAST AFRICAN STANDARD

Plastics piping systems for soil and waste discharge (low and high temperature) inside buildings — Chlorinated poly(vinyl chloride) (PVC-C)

EAST AFRICAN COMMUNITY

Foreword

Development of the East African Standards has been necessitated by the need for harmonizing requirements governing quality of products and services in East Africa. It is envisaged that through harmonized standardization, trade barriers which are encountered when goods and services are exchanged within the Community will be removed.

In order to meet the above objectives, the EAC Partner States have enacted an East African Standardization, Quality Assurance, Metrology and Test Act, 2006 (EAC SQMT Act, 2006) to make provisions for ensuring standardization, quality assurance, metrology and testing of products produced or originating in a third country and traded in the Community in order to facilitate industrial development and trade as well as helping to protect the health and safety of society and the environment in the Community.

East African Standards are formulated in accordance with the procedures established by the East African Standards Committee. The East African Standards Committee is established under the provisions of Article 4 of the EAC SQMT Act, 2006. The Committee is composed of representatives of the National Standards Bodies in Partner States, together with the representatives from the private sectors and consumer organizations. Draft East African Standards are circulated to stakeholders through the National Standards Bodies in the Partner States. The comments received are discussed and incorporated before finalization of standards, in accordance with the procedures of the Community.

Article 15(1) of the EAC SQMT Act, 2006 provides that "Within six months of the declaration of an East African Standard, the Partner States shall adopt, without deviation from the approved text of the standard, the East African Standard as a national standard and withdraw any existing national standard with similar scope and purpose".

East African Standards are subject to review, to keep pace with technological advances. Users of the East African Standards are therefore expected to ensure that they always have the latest versions of the standards they are implementing.

© East African Community 2010 — All rights reserved*

East African Community

P O Box 1096

Arusha

Tanzania

Tel: 255 27 2504253/8

Fax: 255-27-2504481/2504255

E-Mail: eac@eachq.org

Web: www.each.int

* © 2010 EAC — All rights of exploitation in any form and by any means reserved worldwide for EAC Partner States' NSBs.

Introduction

In the preparation of this East African Standard, the following source was consulted extensively:

ISO 7675:2003, *Plastics piping systems for soil and waste discharge (low and high temperature) inside buildings — Chlorinated poly(vinyl chloride) (PVC-C)*

Assistance derived from this source and others inadvertently not mentioned is hereby acknowledged.

Draft for comments only — Not to be cited as East African Standard

**Plastics piping systems for soil and
waste discharge (low and high
temperature) inside buildings —
Chlorinated poly(vinyl chloride) (PVC-C)**

*Systèmes de canalisations en plastique pour l'évacuation des eaux-
vannes et des eaux usées (à basse et à haute température) à l'intérieur
des bâtiments — Poly(chlorure de vinyle) chloré (PVC-C)*

Draft for comments only — Not to be used



PDF disclaimer

This PDF file may contain embedded typefaces. In accordance with Adobe's licensing policy, this file may be printed or viewed but shall not be edited unless the typefaces which are embedded are licensed to and installed on the computer performing the editing. In downloading this file, parties accept therein the responsibility of not infringing Adobe's licensing policy. The ISO Central Secretariat accepts no liability in this area.

Adobe is a trademark of Adobe Systems Incorporated.

Details of the software products used to create this PDF file can be found in the General Info relative to the file; the PDF-creation parameters were optimized for printing. Every care has been taken to ensure that the file is suitable for use by ISO member bodies. In the unlikely event that a problem relating to it is found, please inform the Central Secretariat at the address given below.

© ISO 2003

All rights reserved. Unless otherwise specified, no part of this publication may be reproduced or utilized in any form or by any means, electronic or mechanical, including photocopying and microfilm, without permission in writing from either ISO at the address below or ISO's member body in the country of the requester.

ISO copyright office
Case postale 56 • CH-1211 Geneva 20
Tel. + 41 22 749 01 11
Fax + 41 22 749 09 47
E-mail copyright@iso.org
Web www.iso.org

Published in Switzerland

Contents

Page

Foreword	iv
Introduction	v
1 Scope	1
2 Normative references	1
3 Symbols and abbreviations	2
4 Material	3
5 General characteristics	4
6 Geometrical characteristics	4
7 Mechanical characteristics of pipes	21
8 Physical characteristics	23
9 Performance requirements	24
10 Sealing rings	25
11 Adhesives	25
12 Marking	25
13 Installation of piping systems	27
Annex A (informative) Additional characteristics of PVC-C pipes and fittings	28
Bibliography	29

Foreword

ISO (the International Organization for Standardization) is a worldwide federation of national standards bodies (ISO member bodies). The work of preparing International Standards is normally carried out through ISO technical committees. Each member body interested in a subject for which a technical committee has been established has the right to be represented on that committee. International organizations, governmental and non-governmental, in liaison with ISO, also take part in the work. ISO collaborates closely with the International Electrotechnical Commission (IEC) on all matters of electrotechnical standardization.

International Standards are drafted in accordance with the rules given in the ISO/IEC Directives, Part 2.

The main task of technical committees is to prepare International Standards. Draft International Standards adopted by the technical committees are circulated to the member bodies for voting. Publication as an International Standard requires approval by at least 75 % of the member bodies casting a vote.

Attention is drawn to the possibility that some of the elements of this document may be the subject of patent rights. ISO shall not be held responsible for identifying any or all such patent rights.

ISO 7675 was prepared by Technical Committee ISO/TC 138, *Plastics pipes, fittings and valves for the transport of fluids*, Subcommittee SC 1, *Plastics pipes and fittings for soil, waste and drainage (including land drainage)*.

This second edition cancels and replaces the first edition (ISO 7675:1991), which has been technically revised.

In this corrected version of ISO 7675:2003, Table 8 has been amended so that the column headings for "other socket dimensions" read:

<i>A</i>	<i>B</i>	<i>C</i>	<i>N</i>
min.	min.	max.	min.

Introduction

Pipes and fittings conforming to this International Standard also meet the requirements of EN 1566-1 which are applicable to those pipes and fittings which, according to EN 1566-1, are intended to be used inside buildings (application area code "B", see EN 1566-1) only.

Draft for comments only — Not to be cited as East African Standard

Draft for comments only — Not to be cited as East African Standard

Plastics piping systems for soil and waste discharge (low and high temperature) inside buildings — Chlorinated poly(vinyl chloride) (PVC-C)

1 Scope

This International Standard specifies the requirements for chlorinated poly(vinyl chloride) (PVC-C) pipes and fittings for soil and waste discharge (low and high temperature) inside buildings, as well as the system itself. It does not include buried pipework.

It also specifies the test parameters for the test methods referred to in this International Standard.

This International Standard is applicable to PVC-C pipes and fittings, as well as assemblies of such pipes and fittings, intended to be used for the following purposes:

- a) soil and waste discharge pipework for the conveyance of domestic waste waters (low and high temperature);
- b) ventilation pipework associated with a);
- c) rainwater pipework inside the building.

It is applicable to pipes and fittings designed for jointing by means of elastomeric sealing rings, solvent cementing or integral dual-purpose sockets, i.e. for elastomeric ring seal joints and/or for solvent cement joints.

2 Normative references

The following referenced documents are indispensable for the application of this document. For dated references, only the edition cited applies. For undated references, the latest edition of the referenced document (including any amendments) applies.

ISO 265-1, *Pipes and fittings of plastics materials — Fittings for domestic and industrial waste pipes — Basic dimensions: Metric series — Part 1: Unplasticized poly(vinyl chloride) (PVC-U)*

ISO 3126:—¹⁾, *Plastics piping systems — Plastics components — Determination of dimensions*

ISO 8361-1, *Thermoplastics pipes and fittings — Water absorption — Part 1: General test method*

EN 681-1, *Elastomeric seals — Materials requirements for pipe joint seals used in water and drainage applications — Part 1: Vulcanized rubber*

EN 681-2, *Elastomeric seals — Materials requirements for pipe joint seals used in water and drainage applications — Part 2: Thermoplastic elastomers*

1) To be published. (Revision of ISO 3126:1974)

EN 727, *Plastics piping and ducting systems — Thermoplastics pipes and fittings — Determination of Vicat softening temperature (VST)*

EN 743, *Plastics piping and ducting systems — Thermoplastics pipes — Determination of the longitudinal reversion*

EN 744, *Plastics piping and ducting systems — Thermoplastics pipes — Test method for resistance to external blows by the round-the-clock method*

EN 763, *Plastics piping and ducting systems — Injection-moulded thermoplastics fittings — Test method for visually assessing effects of heating*

EN 1053, *Plastics piping systems — Thermoplastics piping systems for non-pressure applications — Test method for watertightness*

EN 1054, *Plastics piping systems — Thermoplastics piping systems for soil and waste discharge — Test method for airtightness of joints*

EN 1055:1996, *Plastics piping systems — Thermoplastics piping systems for soil and waste discharge inside buildings — Test method for resistance to elevated temperature cycling*

EN 1411, *Plastics piping and ducting systems — Thermoplastics pipes — Determination of resistance to external blows by the staircase method*

3 Symbols and abbreviations

3.1 Symbols

A	length of engagement
B	length of lead-in
C	depth of sealing zone
d_e	outside diameter (at any point)
d_{em}	mean outside diameter
d_n	nominal outside diameter
d_s	inside diameter of the socket
d_{sm}	mean inside diameter of the socket
DN	nominal size
DN/OD	nominal size (outside-diameter related)
e	wall thickness (at any point)
e_m	mean wall thickness
e_2	wall thickness of the socket
e_3	wall thickness at the groove
L_1	length of spigot

L_2	length of solvent cement socket
l	effective length of a pipe
N	effective insertion depth
R	radius of swept fittings
z	design length (z -length) of a fitting
α	nominal angle of a fitting

3.2 Abbreviations

PVC-C	chlorinated poly(vinyl chloride)
TIR	true impact rate

4 Material

4.1 PVC-C compound

The compound for pipes and fittings shall be PVC-C to which may be added up to 50 % PVC-U and those additives that are needed to facilitate the manufacture of components conforming to the requirements of this International Standard.

In order to conform to national requirements on fire regulations, other additives may be used.

Fabricated fittings or parts of fabricated fittings shall be made from pipes and/or mouldings conforming to this International Standard, except for the requirements for the wall thickness of fabricated fittings and/or mouldings from PVC-C which conform to material, mechanical and physical characteristics as required in this International Standard.

4.2 Reprocessable and recyclable material

In addition to virgin material, the use of reprocessible material obtained during the production and testing of products conforming to this International Standard is permitted. External reprocessible or recyclable material shall not be used.

NOTE Definitions concerning materials are given in EN 1566-1.

4.3 Sealing ring retaining means

Sealing rings may be retained, using means made from plastics other than PVC-C, provided the joints conform to the requirements given in Clause 9.

4.4 Fire behaviour

No specific requirements are set by this International Standard for fire behaviour. Attention is drawn to the need to comply with any relevant national regulations in this respect.

5 General characteristics

5.1 Appearance

When viewed without magnification, the following requirements shall be met:

- the internal and external surfaces of pipes and fittings shall be smooth, clean and free from grooving, blistering, impurities, pores or any other surface irregularity likely to prevent conformity of pipes and fittings to this International Standard;
- each end of a pipe or fitting shall be cleanly cut, if applicable, and shall be square to its axis.

5.2 Colour

Pipes and fittings shall be uniformly coloured through the whole wall.

The recommended colour for pipes and fittings is grey or black.

6 Geometrical characteristics

6.1 General

All dimensions shall be measured in accordance with ISO 3126.

The figures given in this International Standard are schematic sketches only, to indicate the relevant dimensions. They do not necessarily represent manufactured components. The dimensions given shall be conformed to however.

6.2 Dimensions of pipes

6.2.1 Outside diameter

The mean outside diameter, d_{em} , shall conform to Table 1 or Table 2, as applicable.

Table 1 — Mean outside diameters
(metric series)

Dimensions in millimetres

Nominal size DN/OD	Nominal outside diameter d_n	Mean outside diameter d_{em}	
		min.	max.
32	32	32,0	32,3
40	40	40,0	40,3
50	50	50,0	50,3
63	63	63,0	63,3
75	75	75,0	75,4
80	80	80,0	80,4
90	90	90,0	90,4
100	100	100,0	100,4
110	110	110,0	110,4
125	125	125,0	125,4
160	160	160,0	160,5

Table 2 — Mean outside diameters
(series based on inch dimensions)

Dimensions in millimetres

Nominal size DN/OD	Nominal outside diameter d_n	Mean outside diameter d_{em}	
		min.	max.
36	36	36,1	36,5
43	43	42,7	43,1
55	55	55,7	56,1

6.2.2 Effective length of pipes

The effective length, l , of a pipe shall not be less than that declared by the manufacturer and shall be measured as shown in Figure 1. For pipes with sockets, the effective length is considered to be the distance between the pipe ends minus the socket length. For practical reasons, this length is measured to the outside of the socket.

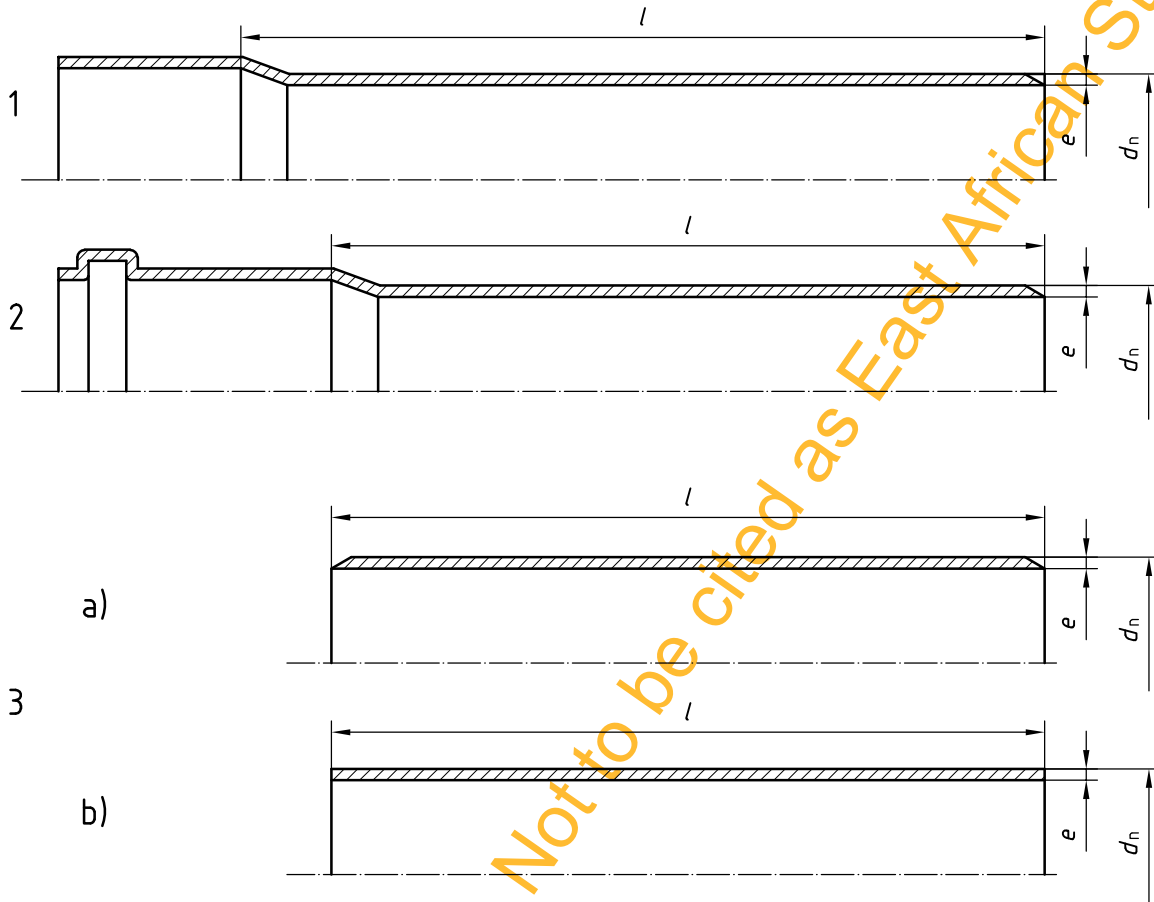

- Key**
- 1 single socket pipe
 - 2 ring seal pipe
 - 3 plain-ended pipes
 - a) with chamfer
 - b) without chamfer

Figure 1 — Effective lengths of pipes

6.2.3 Chamfering

If a chamfer is applied, the angle of chamfering shall be between 15° and 45° to the axis of the pipe (see Figure 3). When pipes without a chamfer are used, the pipe ends shall be deburred.

The remaining wall thickness of the end of the pipe shall be at least 1/3 of e_{min} .

6.2.4 Wall thickness

The wall thickness, e , shall conform to Table 3 or Table 4, as applicable, but for the metric series a maximum wall thickness at any point of up to $1,25e_{min}$ is permitted, provided that the mean wall thickness, e_m , is less than or equal to the specified $e_{m,max}$.

Table 3 — Wall thicknesses
(metric series)

Dimensions in millimetres

Nominal size DN/OD	Nominal outside diameter d_n	Wall thickness	
		e min.	e_m max.
32	32	1,8	2,2
40	40	1,8	2,2
50	50	1,8	2,2
63	63	1,8	2,2
75	75	1,8	2,2
80	80	1,8	2,2
90	90	1,8	2,2
100	100	2	2,5
110	110	2,2	2,7
125	125	2,5	3
160	160	3,2	3,8

Table 4 — Wall thicknesses
(series based on inch dimensions)

Dimensions in millimetres

Nominal size DN/OD	Nominal outside diameter d_n	Wall thickness	
		e min.	e_m max.
36	36	1,8	2,2
43	43	1,9	2,3
55	55	2	2,4

6.3 Dimensions of fittings

6.3.1 Outside diameters

The mean outside diameter, d_{em} , of the spigot end shall conform to Table 1 or Table 2, as applicable.

6.3.2 z -lengths

The design length(s) [z -length(s)] of fittings (see Figure 8 to Figure 21) shall be as given by the manufacturer.

NOTE The z -length(s) of a fitting are intended to assist in the design of moulds and are not intended to be used for quality control purposes. ISO 265-1 may be used as a guideline.

6.3.3 Wall thickness

The minimum wall thickness, e_{\min} , of the body or the spigot end of a fitting shall conform to Table 3 or Table 4, as applicable, except that a reduction of 5 % resulting from core shifting is permitted. In such cases, the average of two opposite wall thicknesses shall be equal to or greater than the values given in Table 3 or Table 4, as applicable.

Where a fitting or adaptor provides a transition between two nominal sizes, the wall thickness of each connecting part shall conform to the requirements for the applicable nominal size. In such cases, the wall thickness of the fitting body is permitted to change gradually from the one wall thickness to the other.

Where a sealing ring is located by means of a retaining cap or ring (see Figure 2), the wall thickness in this area shall be calculated by addition of the wall thickness of the socket and the wall thickness of the retaining cap or ring at the corresponding places in the same cross-sectional plane.

The wall thicknesses of fabricated fittings, except for spigot ends and sockets, may be changed locally to suit the fabrication process, provided that the minimum wall thickness of the body conforms to the minimum value of e_3 as given in Table 9 or Table 10, as applicable.

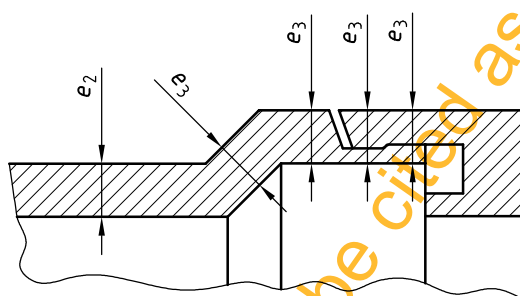

Figure 2 — Example of calculation of wall thickness of socket with retaining cap

6.4 Dimensions of sockets and pipe ends

6.4.1 Classification and designation of sockets

6.4.1.1 General

Sockets shall be classified according to the type of joint for which they are intended, as indicated in 6.4.1.2 to 6.4.1.4.

6.4.1.2 Ring seal sockets

The lengths of ring seal sockets of type S, type N and type L and of spigot ends are designed for pipes of different lengths:

- **Type S** (short): This socket type (see Figure 4) may be used as an expansion joint system where the length of a pipe does not exceed 2 m. If this socket type is part of a fixed joint system (i.e. a system which does not in itself allow for expansion and contraction), it shall be used in conjunction with a type L (long) socket as specified in this International Standard.
- **Type N** (normal): This socket type (see Figure 4) may be used as an expansion joint system. If this socket type is part of a fixed joint system (i.e. a system which does not in itself allow for expansion and contraction), it shall be used in conjunction with a type L (long) socket as specified in this International Standard. The values for the length of engagement, A , given in Table 6 or Table 7, as applicable, are related to a pipe length of 3 m.

- **Type L** (long): This socket type (see Figure 5) may be used as an expansion joint in fixed joint systems (i.e. systems which do not in themselves allow for expansion and contraction), whether jointed by ring seal or solvent cement or for use with sockets of type S or type N, as applicable, where the length of pipe exceeds the maximum given for these types.

6.4.1.3 Solvent cement sockets

The classification includes the following type:

- **Type CS** (short type for solvent cement joints): This socket type (see Figure 7) may be used where jointing is carried out under controlled conditions.

6.4.1.4 Dual-purpose sockets

This socket type (see Figure 4) is intended to be used for a connection made either using a sealing ring or using solvent cement applied after removal of the sealing ring, if any.

Sockets of type S and type N (see 6.4.1.2) may be used as dual-purpose sockets.

6.4.2 Dimensions of ring seal sockets and spigot ends

6.4.2.1 Diameters and lengths

The diameters and lengths of ring seal sockets and spigot ends (see Figure 3, Figure 4 and Figure 5) shall conform to one of the following tables:

- Table 5 for type S and dual-purpose (see Figure 4);
- Table 6 or Table 7, as applicable, for type N and dual-purpose (see Figure 4);
- Table 8 for type L (see Figure 5);

and shall be in accordance with the following conditions:

- where sealing rings are firmly retained, the minimum value of A and the maximum value of C shall be as measured to the effective sealing point (see Figure 6 for an example) and this point shall give a full sealing action;
- where sealing rings are firmly retained, the required values given for dimension B (see Figure 4 or Figure 5) do not apply.

Different designs of ring seal socket (see Figure 4) may be used, provided the joints conform to the requirements given in Clause 9.

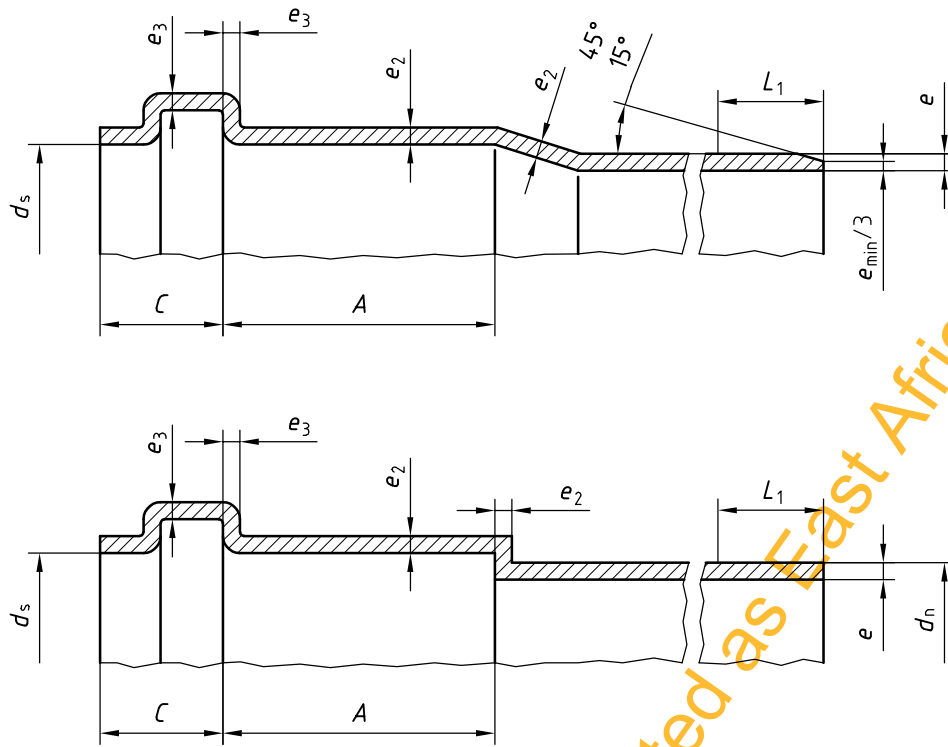

Figure 3 — Dimensions of sockets and spigot ends for ring seal joints

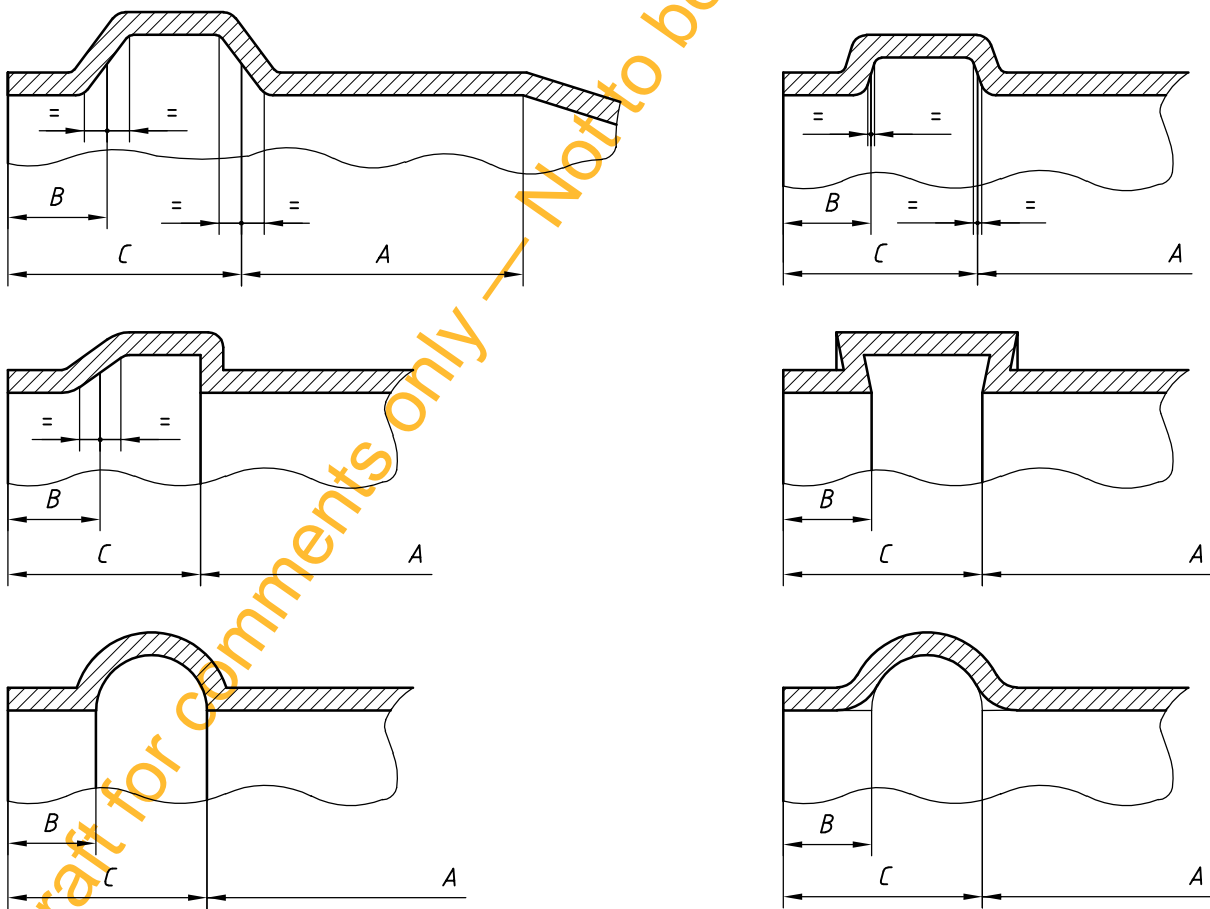

Figure 4 — Typical groove designs for type S, type N and dual-purpose ring seal sockets

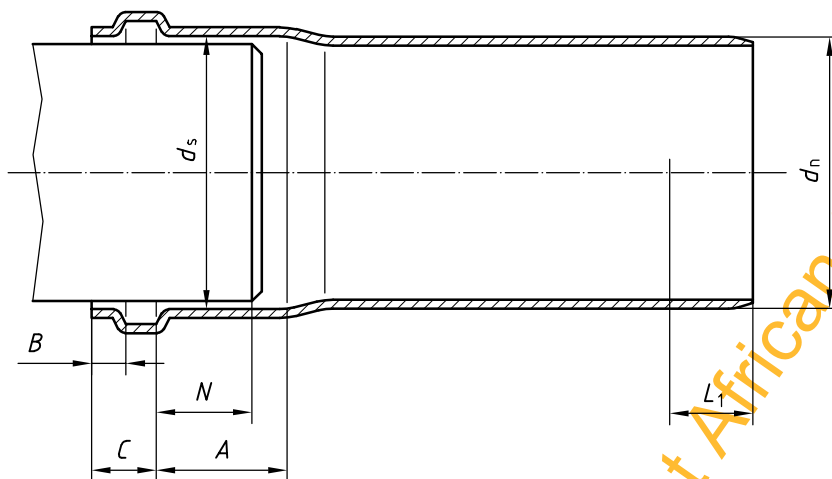

Figure 5 — Example of a type L ring seal socket

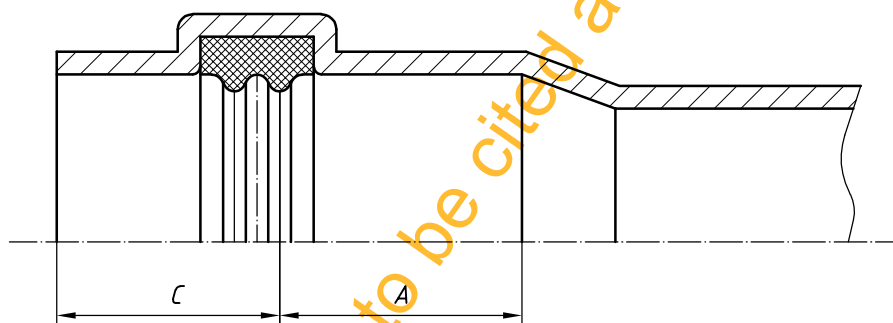

Figure 6 — Example of measurement of effective sealing point

Table 5 — Diameters and lengths of type S and dual-purpose ring seal sockets and spigot ends (metric series)

Dimensions in millimetres

Nominal size DN/OD	Nominal outside diameter d_n	Mean inside diameter of socket d_{sm}		Other socket dimensions			Length of spigot end L_1
		min.	max. ^b	A^a min.	B min.	C max.	
32	32	32,3	32,7	16	5	18	34
40	40	40,3	40,7	18		18	36
50	50	50,3	50,7	20		18	38
63	63	63,3	63,8	23		18	41
75	75	75,3	75,8	25		20	43
80	80	80,3	80,8	26		21	44

^a The minimum value of A corresponds to an effective pipe length of 3 m.

^b Required for dual-purpose sockets only.

Table 6 — Diameters and lengths of type N and dual-purpose ring seal sockets and spigot ends (metric series)

Dimensions in millimetres

Nominal size DN/OD	Nominal outside diameter d_n	Mean inside diameter of socket		Other socket dimensions			Length of spigot end
		d_{sm}		A	B	C	L_1
		min.	max. ^a	min.	min.	max.	min.
32	32	32,3	32,7	24	5	18	42
40	40	40,3	40,7	26	5	18	44
50	50	50,3	50,7	28	5	18	46
63	63	63,3	63,7	31	5	18	49
75	75	75,4	75,8	33	5	18	51
80	80	80,4	80,8	34	5	18	52
90	90	90,4	90,8	36	5	20	56
100	100	100,4	100,8	36	6	21	57
110	110	110,4	110,8	36	6	22	58
125	125	125,4	125,9	38	7	26	64
160	160	160,5	161,0	41	9	32	73

^a Required for dual-purpose sockets only.

Table 7 — Diameters and lengths of type N and dual-purpose ring seal sockets and spigot ends (series based on inch dimensions)

Dimensions in millimetres

Nominal size DN/OD	Nominal outside diameter d_n	Mean inside diameter of socket		Other socket dimensions			Length of spigot end
		d_{sm}		A	B	C	L_1
		min.	max. ^a	min.	min.	max.	min.
36	36	36,5	37,2	25	3,8	12	37
43	43	43,1	43,8	25	3,8	15	40
55	55	56,1	56,8	25	3,8	18	43

^a Required for dual-purpose sockets only.

Table 8 — Diameters and lengths of type L ring seal sockets and spigot ends
(metric series)

Dimensions in millimetres

Nominal size DN/OD	Nominal outside diameter d_n	Mean inside diameter of socket d_{sm} min.	Other socket dimensions				Length of spigot end L_1 min.
			A min.	B min.	C max.	N min.	
32	32	32,4		5	18		35
40	40	40,4		5	18		36
50	50	50,4		5	18		38
63	63	63,4		5	18		40
75	75	75,4		5	20		43
80	80	80,4	65	5	22	45	44
90	90	90,4		5	23		46
100	100	100,5		6	25		50
110	110	110,5		6	26		54
125	125	125,5		7	28		60
160	160	160,6		9	32		74

6.4.2.2 Wall thicknesses of ring seal sockets

The wall thickness of the socket, e_2 , and the wall thickness in the groove area, e_3 , shall conform to Table 9 or Table 10, as applicable.

Table 9 — Wall thicknesses of sockets
(metric series)

Dimensions in millimetres

Nominal size DN/OD	Nominal outside diameter d_n	Wall thicknesses	
		e_2 min.	e_3 min.
32	32	1,7	1,0
40	40	1,7	1,0
50	50	1,7	1,0
63	63	1,7	1,0
75	75	1,7	1,0
80	80	1,7	1,0
90	90	1,7	1,0
100	100	1,8	1,1
110	110	2,0	1,3
125	125	2,3	1,4
160	160	2,9	1,8

Table 10 — Wall thicknesses of sockets
(series based on inch dimensions)

Dimensions in millimetres

Nominal size DN/OD	Nominal outside diameter d_n	Wall thicknesses	
		e_2 min.	e_3 min.
36	36	1,7	1,0
43	43	1,8	1,1
55	55	1,8	1,1

6.4.3 Dimensions of solvent cement sockets and spigot ends

6.4.3.1 Diameters and lengths

The diameters and lengths of solvent cement sockets and spigot ends (see Figure 7) shall conform to Table 11 or Table 12, as applicable.

Solvent cement joints are intended to be used only in conjunction with those joints and practices which accommodate expansion and contraction in conformity with the relevant installation techniques. Joints made using solvent cement are rigid and do not in themselves allow for expansion and contraction due to temperature variations.

Within the tolerances necessary for manufacturing, solvent cement sockets shall be approximately cylindrical.

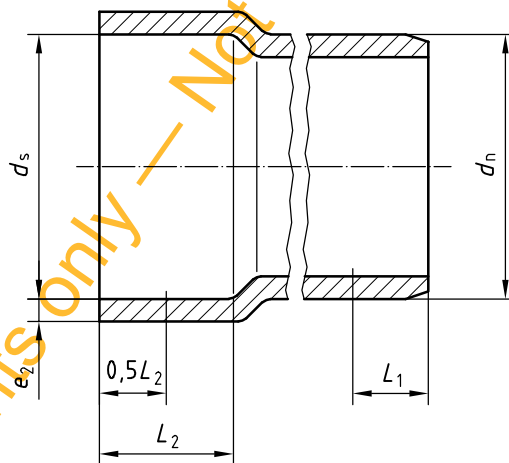

Figure 7 — Example of a type CS solvent cement socket and spigot end

Table 11 — Diameters and lengths of type CS solvent cement sockets and spigot ends
(metric series)

Dimensions in millimetres

Nominal size DN/OD	Nominal outside diameter d_n	Mean inside diameter of socket ^a d_{sm}		Length of socket L_2 min.	Length of spigot end L_1 min.
		min.	max.		
32	32	32,1	32,5	17	17
40	40	40,1	40,5	18	18
50	50	50,1	50,5	20	20
63	63	63,1	63,5	23	23
75	75	75,1	75,5	25	25
80	80	80,1	80,5	26	26
90	90	90,1	90,5	28	28
100	100	100,1	100,6	30	30
110	110	110,2	110,7	32	32
125	125	125,2	125,8	35	35
160	160	160,2	160,9	42	42

^a Except for sockets for which the ratio $e_{2,min}/d_{em}$ is less than 0,035, the tolerance on ovality of any cross-sectional plane of inside diameter, d_s , of the socket shall conform to the following condition: $d_{s,max} - d_{s,min} \leq 0,011d_e$.

Table 12 — Diameters and lengths of type CS solvent cement sockets and spigot ends
(series based on inch dimensions)

Dimensions in millimetres

Nominal size DN/OD	Nominal outside diameter d_n	Mean inside diameter of socket ^a d_{sm}		Length of socket L_2 min.	Length of spigot end L_1 min.
		min.	max.		
36	36	36,1	36,7	18	18
43	43	42,7	43,3	21	21
55	55	55,7	56,3	27	27

^a Except for sockets for which the ratio $e_{2,min}/d_{em}$ is less than 0,035, the tolerance on ovality of any cross-sectional plane of inside diameter, d_s , of the socket shall conform to the following condition: $d_{s,max} - d_{s,min} \leq 0,011d_e$.

6.4.3.2 Wall thicknesses of solvent cement sockets

The wall thicknesses of solvent cement sockets, e_2 , shall conform to Table 9 or Table 10, as applicable.

6.5 Types of fitting

This International Standard is applicable to the following types of fitting. Other designs of fittings are permitted.

a) Bends (see Figure 8, 9, 10, 11 or 12):

- unswept or swept angle (see ISO 265-1);
- spigot/socket or socket/socket;
- solvent-cemented from segments.

The nominal angle, α , may be selected from the following: 15°, 22°30', 30°, 45°, 67°30', 80°, 87°30' to 90°.

b) Branches and reducing branches (branching single or multiple) (see Figure 13, 14, 15, 16, 17 or 18):

- unswept or swept angle (see ISO 265-1);
- spigot/socket or socket/socket.

The nominal angle, α , may be selected from the following: 45°, 67°30', 87°30' to 90°.

c) Saddle branches and reducing saddle branches (see Figure 19).

The nominal angle, α , may be selected from the following: 45°, 67°30', 80°, 87°30' to 90°.

If other angles are required, they shall be agreed between the manufacturer and purchaser and be identified accordingly.

d) Reducers (see Figure 20).

e) Access fittings (see Figure 21).

The inside diameter of the cleaning hole shall be as specified by the manufacturer.

f) Couplers:

- double-socket (see Figure 22);
- repair collar (see Figure 23).

g) Plugs (see Figure 24).

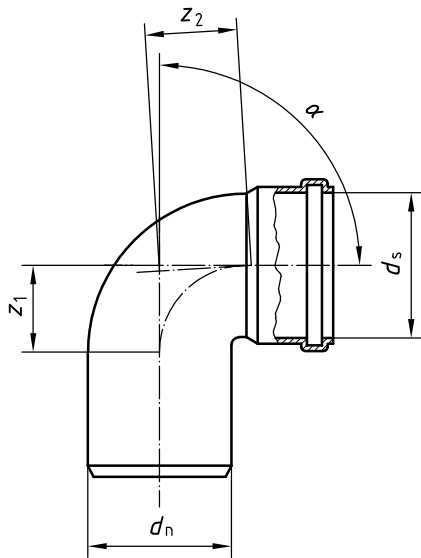

Figure 8 — Bend with single socket (unswept)

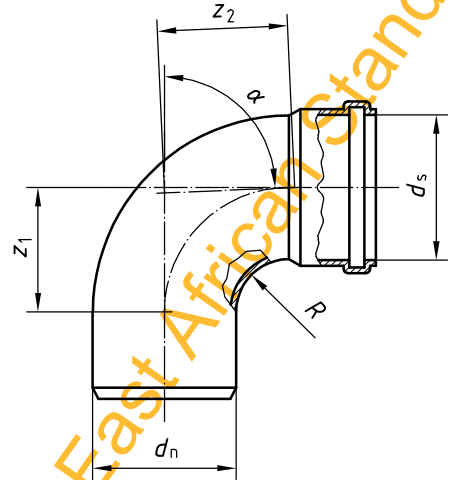

Figure 9 — Bend with single socket (swept)

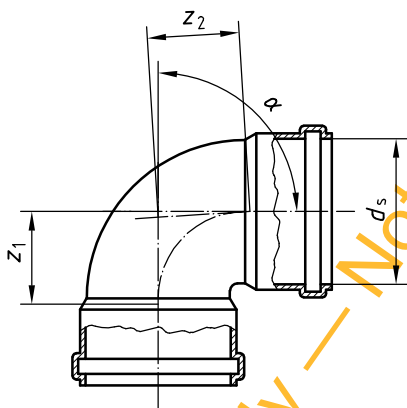

Figure 10 — Bend with only sockets (unswept)

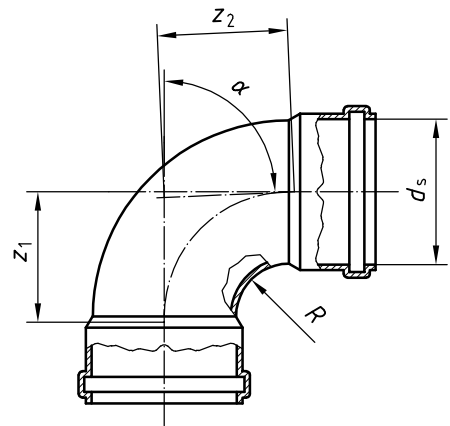

Figure 11 — Bend with only sockets (swept)

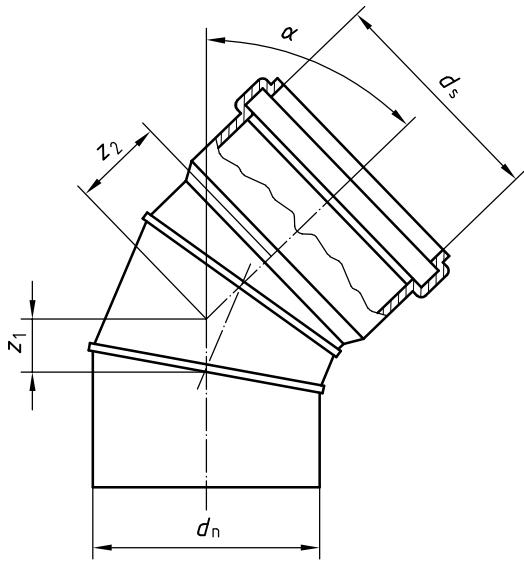

Figure 12 — Bend with single socket, solvent-cemented from segments

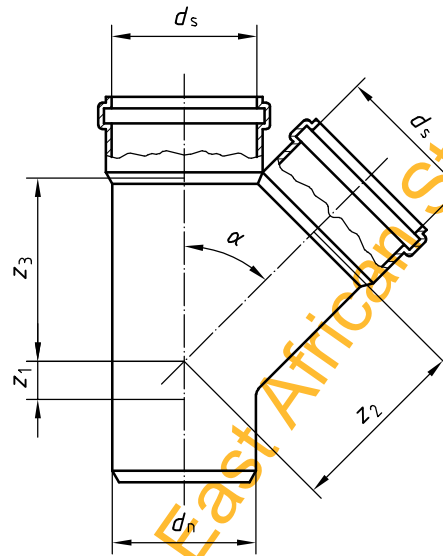

Figure 13 — Branch (unswept)

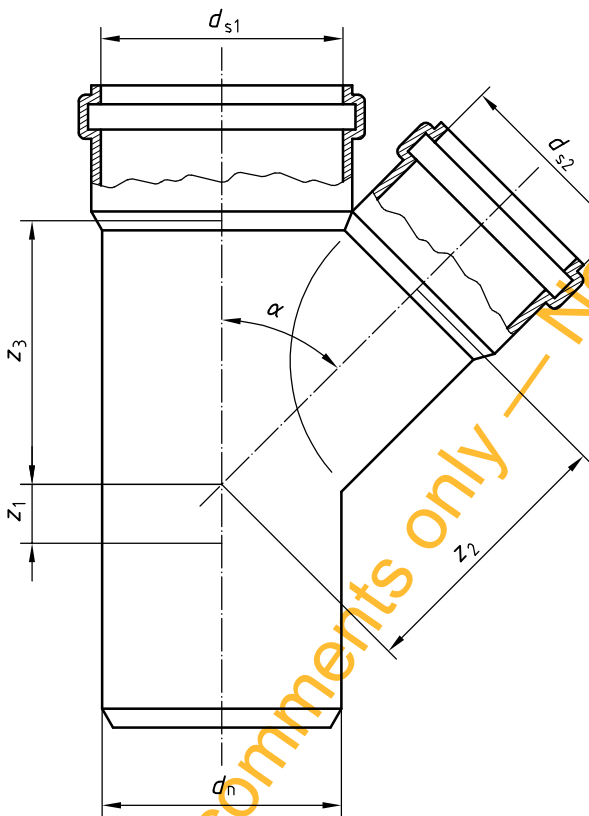

Figure 14 — Reducing branch (unswept)

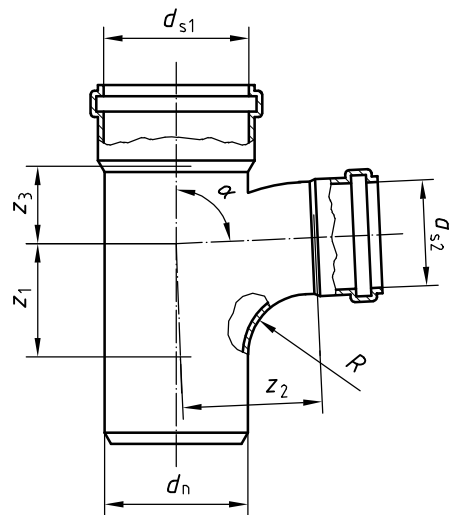

Figure 15 — Reducing branch (swept)

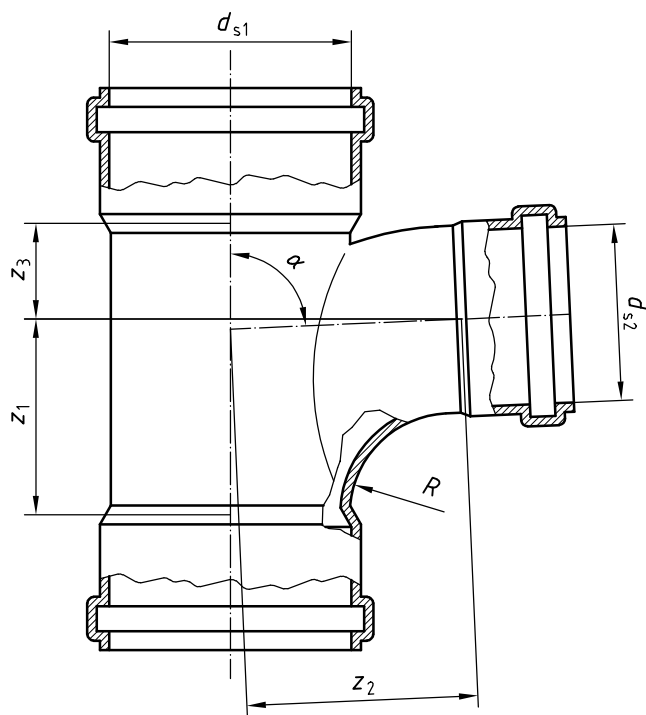

Figure 16 — Reducing branch with only sockets (swept)

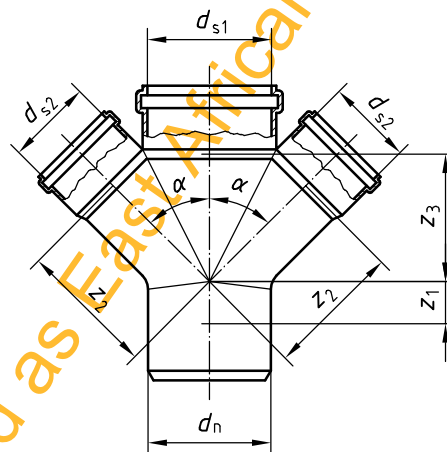

Figure 17 — Double branch

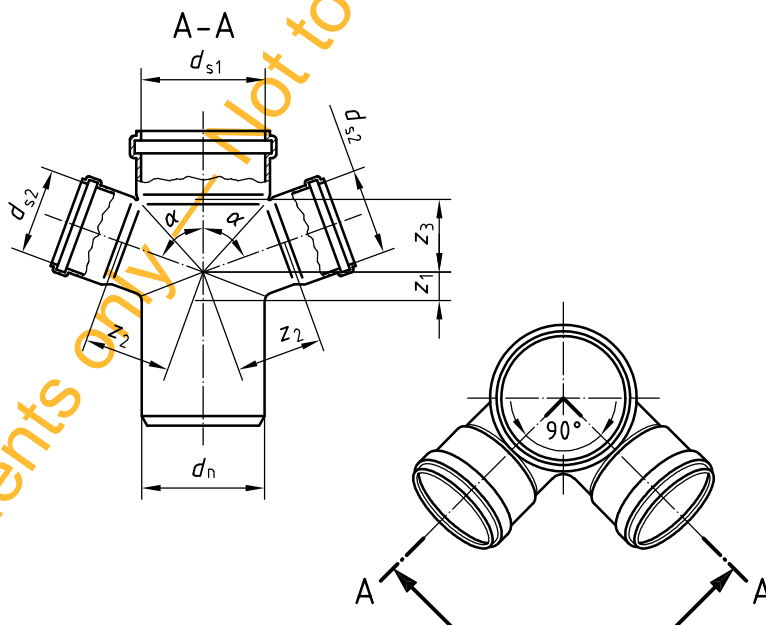

Figure 18 — Angular double branch

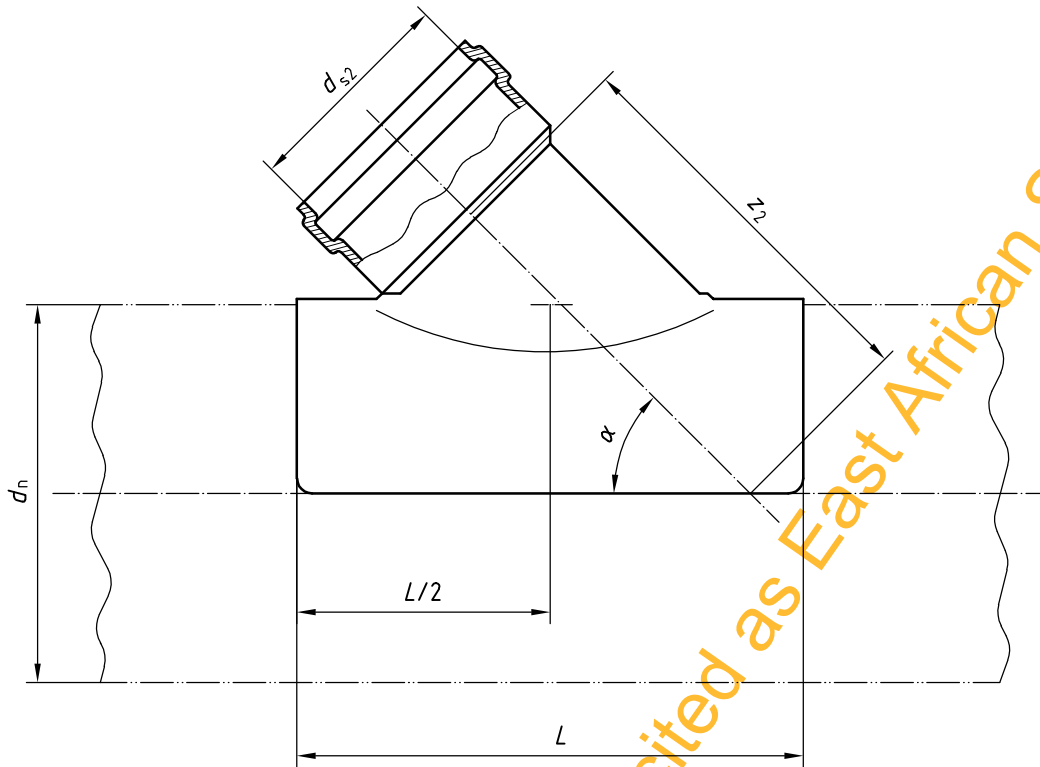

Figure 19 — Saddle branch

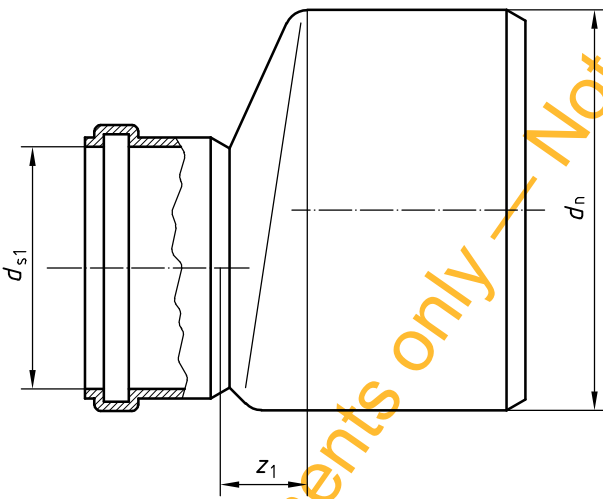

Figure 20 — Reducer

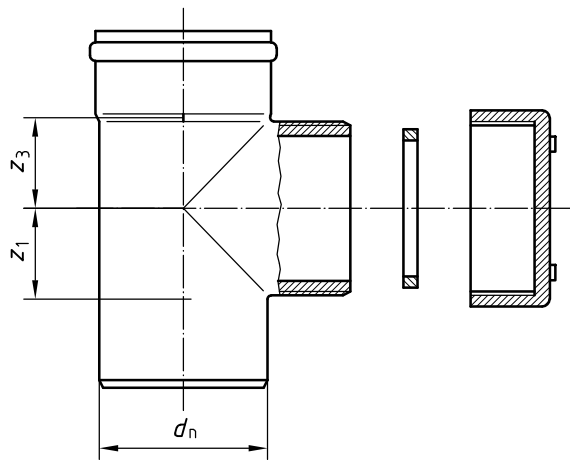

Figure 21 — Access fitting with round cleaning hole

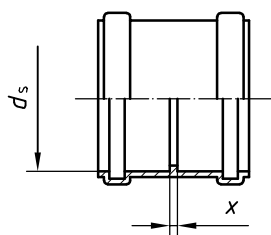

Figure 22 — Double-socket (coupler)

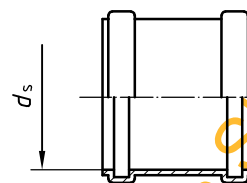

Figure 23 — Repair collar

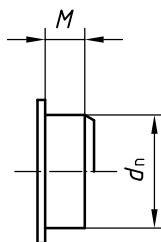

Figure 24 — Plug

7 Mechanical characteristics of pipes

7.1 General characteristics

When determined in accordance with the method specified in Table 13, using the parameters indicated, the general mechanical characteristics of pipes shall conform to the requirements given in Table 13.

The mass and drop height of the striker used in determining the impact resistance (round-the-clock method) as specified in Table 13 are given in Table 14 or Table 15, as applicable.

Table 13 — General mechanical characteristics of pipes

Characteristic	Requirements	Test parameters		Test method
Impact resistance (round-the-clock method)	TIR ≤ 10 %	Type of striker for: $d_n < 110$ mm $d_n ≥ 110$ mm Mass of striker Drop height of striker Conditioning medium Conditioning and test temperature Conditioning period	Type d25 Type d90 Table 14 or Table 15, as applicable Table 14 or Table 15, as applicable Water or air (0 ± 1) °C 60 min	EN 744

Table 14 — Mass and drop height of striker for impact resistance (round-the-clock method)
(metric series)

Dimensions in millimetres

Nominal size DN/OD	Nominal outside diameter d_n	Mass of striker kg +0,01 0	Drop height of striker +20 0
32	32	0,5	600
40	40	0,5	800
50	50	0,5	1 000
63	63	0,8	1 000
75	75	0,8	1 000
80	80	0,8	1 000
90	90	0,8	1 200
100	100	0,8	1 200
110	110	0,8	2 000
125	125	1,25	2 000
160	160	1,6	2 000

Table 15 — Mass and drop height of striker for impact resistance (round-the-clock method)
(series based on inch dimensions)

Dimensions in millimetres

Nominal size DN/OD	Nominal outside diameter d_n	Mass of striker kg +0,01 0	Drop height of striker +20 0
36	36	0,5	600
43	43	0,5	800
55	55	0,5	1 000

7.2 Additional characteristics

Pipes intended to be used in areas where installation is usually carried out at temperatures below – 10 °C shall additionally conform to the requirements of an impact test (staircase method), as specified in Table 16.

The pipes shall be marked in accordance with Table 21.

Table 16 — Additional mechanical characteristics of pipes

Characteristic	Requirements	Test parameters		Test method
Impact resistance (staircase method)	$H_{50} \geq 1$ m Max.: 1 break below 0,5 m	Conditioning and test temperature	(0 ± 1) °C	EN 1411
		Type of striker	Type d90	
		Mass of striker for:		
		$32 \text{ mm} \leq d_n \leq 43 \text{ mm}$	1,25 kg	
		$50 \text{ mm} \leq d_n \leq 63 \text{ mm}$	2 kg	
		$75 \text{ mm} \leq d_n \leq 80 \text{ mm}$	2,5 kg	
		$90 \text{ mm} \leq d_n \leq 100 \text{ mm}$	3,2 kg	
		$d_n = 110 \text{ mm}$	4 kg	
$d_n = 125 \text{ mm}$	5 kg			
$d_n = 160 \text{ mm}$	8 kg			

8 Physical characteristics

8.1 Physical characteristics of pipes

When determined in accordance with the methods specified in Table 17, using the parameters indicated, the physical characteristics of pipes shall conform to the requirements given in Table 17.

Table 17 — Physical characteristics of pipes

Characteristic	Requirements	Test parameters		Test method	
Vicat softening temperature (VST) after conditioning in air	≥ 90 °C	Shall conform to EN 727		EN 727	
		Conditioning	^a		
Vicat softening temperature (VST) after conditioning in water	≥ 80 °C	Shall conform to EN 727		EN 727	
		Conditioning	16 h in water at 90 °C		
Longitudinal reversion ^b	≤ 5 % The pipe shall exhibit no bubbles or cracks	Test temperature	(150 ± 2) °C	EN 743 Method A: Liquid	
		Immersion time	5 min		
		or			
		Test temperature	(150 ± 2) °C	EN 743	
Immersion time	30 min	Method B: Air			
Water absorption	≤ 3 %	Temperature	(90 ± 2) °C	ISO 8361-1	
		Immersion time	20 h		
^a 2 h in an oven with air circulation at (90 ± 2) °C, then cool for (15 ± 1) min at (23 ± 2) °C and (50 ± 5) % relative humidity, then hold for 5 min at a temperature at least 50 °C lower than the expected softening temperature.					
^b The choice of method A or method B is the responsibility of the manufacturer.					

8.2 Physical characteristics of fittings

When determined in accordance with the methods specified in Table 18 and Table 19, using the parameters indicated, the physical characteristics of fittings shall conform to the requirements given in Table 18 or Table 19, as applicable.

Table 18 — Physical characteristics of fittings

Characteristic	Requirements	Test parameters		Test method
Vicat softening temperature (VST)	≥ 90 °C	Shall conform to EN 727 Conditioning		EN 727
Effects of heating	^b	Test temperature	(150 ± 2) °C	EN 763
		Heating time	30 min	Method A: Air oven
Water absorption	≤ 3 %	Temperature	(90 ± 2) °C	ISO 8361-1
		Immersion time	20 h	

^a 2 h in an oven with air circulation at (90 ± 2) °C, then cool for (15 ± 1) min at (23 ± 2) °C and (50 ± 5) % relative humidity, then hold for 5 min at a temperature at least 50 °C lower than the expected softening temperature.

^b 1) The depth of any cracks, delaminations or blisters shall not exceed 50 % of the wall thickness around the injection point(s). No part of the weld line shall be open to a depth of more than 50 % of the wall thickness. At all other points on the surface, the depth of any cracks or delaminations shall not exceed 30 % of the wall thickness at that point.
 2) When fittings are manufactured from pipes, the pipes shall conform to the requirements given in Table 13 and Table 17.
 3) Mouldings that are used for fabricated fittings may be tested separately.

Table 19 — Physical characteristics of fabricated fittings

Characteristic	Requirement	Test parameters		Test method
Watertightness ^a	No leakage	Water pressure	0,5 bar	EN 1053
		Duration	1 min	

^a Only for fabricated fittings made from more than one piece. A sealing ring retaining element is not considered as a piece.

9 Performance requirements

When determined in accordance with the methods specified in Table 20, using the parameters indicated, the fitness-for-purpose characteristics of the joints and the system shall conform to the requirements given in Table 20.

Table 20 — Fitness-for-purpose characteristics of the system

Characteristic	Requirement	Test parameters	Test method
Watertightness ^a	No leakage	Shall conform to EN 1053	EN 1053
Airtightness ^a	No leakage	Shall conform to EN 1054	EN 1054
Elevated-temperature cycling	No leakage before or after test Sagging for DN ≤ 50: ≤ 3 mm Sagging for DN > 50: ≤ 0,05d _n	Shall conform to EN 1055	Test assembly a) (Figure 1 and/or 3) of EN 1055:1996

^a Not required for solvent cement joints.

10 Sealing rings

10.1 Sealing rings shall not have any detrimental effects on the properties of the pipe or fitting.

10.2 Various designs of sealing ring for ring seal sockets are permitted provided that the joints produced using them conform to the requirements specified in Clause 9.

Materials for sealing rings shall conform to EN 681-1 or EN 681-2, as applicable.

11 Adhesives

11.1 The adhesive used shall be solvent cement as specified by the manufacturer of the pipes or fittings.

11.2 The adhesive shall not have any detrimental effect on the properties of the pipe or fitting. Joints produced using adhesive shall conform to the requirements given in Clause 9.

12 Marking

12.1 General

12.1.1 Marking elements shall be labelled or printed or formed directly on the component in such a way that legibility is maintained during storage, weathering, handling and installation, as well as during the subsequent use of the component.

NOTE The manufacturer is not responsible for marking being illegible due to actions caused during installation and use such as painting, scratching or covering of the components or by use of detergents, etc., on the components unless agreed or specified by the manufacturer.

12.1.2 Marking on a pipe or fitting shall not initiate cracks or other defects likely to prevent conformity to the requirements of this International Standard.

12.2 Minimum required marking of pipes

The minimum marking required for pipes is specified in Table 21.

Pipes shall be marked at intervals of, at the maximum, 1 m, and at least once per pipe. Pipes with a length less than 1 m may be marked with a label at least once per pipe.

Table 21 — Minimum required marking of pipes

Item	Marking or symbol
Number of this International Standard	ISO 7675
Manufacturer's name and/or trade mark	XXX
Nominal size	e.g. DN 110
Minimum wall thickness	e.g. 2,2
Material	PVC-C
Type of socket	e.g. Type N
Manufacturer's information	a
Cold-climate performance ^b	⊛ (ice crystal)
^a To ensure traceability, the following details shall be given: <ul style="list-style-type: none"> — the production period (year and month), in figures or in code; — a name or code for the production site if the manufacturer is producing at different sites. 	
^b This marking is only applicable to pipes which have been proved, by testing, to conform to 7.2.	

12.3 Minimum required marking of fittings

The minimum marking required for fittings is specified in Table 22, whereby the manufacturer's information may be either on the fitting or on the packaging. If the manufacturer's information is on the packaging, it shall be determined by national requirements.

Table 22 — Minimum required marking of fittings

Item	Marking or symbol
Number of this International Standard	ISO 7675
Manufacturer's name and/or trade mark	XXX
Nominal size	e.g. DN 110
Minimum wall thickness	e.g. 2,2
Nominal angle	e.g. 67°30'
Material	PVC-C
Type of socket	e.g. Type N
Manufacturer's information	a
^a To ensure traceability, the following details shall be given: <ul style="list-style-type: none"> — the production period (year and month), in figures or in code; — a name or code for the production site if the manufacturer is producing at different sites. 	

13 Installation of piping systems

For the installation of pipes and fittings conforming to this International Standard, national and/or local requirements and relevant codes of practice shall apply.

In addition, the pipe manufacturer may give a recommended practice for installation which covers the transport, storage and handling of the pipes and fittings as well as to the installation in accordance with the applicable national and/or local instructions.

For external above-ground applications, additional requirements depending on the climate shall be agreed between the manufacturer and the purchaser.

The requirements according to 6.4.1 shall be taken into account.

Guidance on installation may be found in ISO/TR 7024.

Draft for comments only — Not to be cited as East African Standard

Annex A (informative)

Additional characteristics of PVC-C pipes and fittings

A.1 General

EN 476 specifies the general requirements for components used in discharge pipes, drains and sewers for gravity systems. Pipes and fittings conforming to this International Standard fully meet these requirements. Additional information is given in this annex.

A.2 Characteristics relating to the material

Pipes and fittings conforming to this International Standard generally have the following characteristics:

- | | |
|---|--|
| — Modulus of elasticity | $E_{1 \text{ min}} \geq 2\,500 \text{ MPa};$ |
| — Average density | $\approx 1,5 \text{ g/cm}^3;$ |
| — Average coefficient of linear expansion | $\approx 0,07 \text{ mm/m}\cdot\text{K};$ |
| — Thermal conductivity | $\approx 0,17 \text{ W/m}\cdot\text{K};$ |
| — Surface resistance | $> 10^{13} \Omega.$ |

A.3 Chemical resistance

PVC-C piping systems conforming to this International Standard are resistant to corrosion by water with a wide range of pH-values such as soil and waste water, rain water, surface water and ground water.

If piping systems conforming to this International Standard are to be used for waste water contaminated with chemicals, such as industrial discharges, their chemical and temperature resistance will also have to be taken into account.

Guidance is given on the chemical resistance of PVC-C in ISO/TR 10358 and for rubber materials in ISO/TR 7620.

Bibliography

- [1] ISO 161-1, *Thermoplastics pipes for the conveyance of fluids — Nominal outside diameters and nominal pressures — Part 1: Metric series*
- [2] ISO 161-2, *Thermoplastics pipes for the conveyance of fluids — Nominal outside diameters and nominal pressures — Part 2: Inch-based series*
- [3] ISO 3633, *Plastics piping systems for soil and waste discharge (low and high temperature) inside buildings — Unplasticized poly(vinyl chloride) (PVC-U)*
- [4] ISO 4065, *Thermoplastics pipes — Universal wall thickness table*
- [5] ISO/TR 7024, *Above-ground drainage — Recommended practice and techniques for the installation of unplasticized polyvinyl chloride (PVC-U) sanitary pipework for above-ground systems inside buildings*
- [6] ISO/TR 7620, *Rubber materials — Chemical resistance*
- [7] ISO 7671, *Plastics piping systems for soil and waste discharge (low and high temperature) inside buildings — Polypropylene (PP)*
- [8] ISO 7682, *Plastics piping systems for soil and waste discharge (low and high temperature) inside buildings — Acrylonitrile-butadiene-styrene (ABS)*
- [9] ISO 8770, *Plastics piping systems for soil and waste discharge (low and high temperature) inside buildings — Polyethylene (PE)*
- [10] ISO/TR 10358, *Plastics pipes and fittings — Combined chemical-resistance classification table*
- [11] ISO 19220, *Plastics piping systems for soil and waste discharge (low and high temperature) inside buildings — Styrene copolymer blends (SAN + PVC)*
- [12] EN 476, *General requirements for components used in discharge pipes, drains and sewers for gravity systems*
- [13] EN 1329-1, *Plastics piping systems for soil and waste discharge (low and high temperature) within the building structure — Unplasticized poly(vinyl chloride) (PVC-U) — Part 1: Specifications for pipes, fittings and the system*
- [14] EN 1451-1, *Plastics piping systems for soil and waste discharge (low and high temperature) within the building structure — Polypropylene (PP) — Part 1: Specifications for pipes, fittings and the system*
- [15] EN 1453-1, *Plastics piping systems with structured-wall pipes for soil and waste discharge (low and high temperature) inside buildings — Unplasticized poly(vinyl chloride) (PVC-U) — Part 1: Specifications for pipes and the system*
- [16] EN 1455-1, *Plastics piping systems for soil and waste discharge (low and high temperature) within the building structure — Acrylonitrile-butadiene-styrene (ABS) — Part 1: Requirements for pipes, fittings and the system*
- [17] EN 1519-1, *Plastics piping systems for soil and waste discharge (low and high temperature) within the building structure — Polyethylene (PE) — Part 1: Specifications for pipes, fittings and the system*
- [18] EN 1565-1, *Plastics piping systems for soil and waste discharge (low and high temperature) within the building structure — Styrene copolymer blends (SAN + PVC) — Part 1: Specifications for pipes, fittings and the system*

- [19] EN 1566-1, *Plastics piping systems for soil and waste discharge (low and high temperature) within the building structure — Chlorinated poly(vinyl chloride) (PVC-C) — Part 1: Specifications for pipes, fittings and the system*
- [20] EN 12056-1, *Gravity drainage systems inside buildings — Part 1: General and performance requirements*
- [21] ENV 13801, *Plastics piping systems for soil and waste discharge (low and high temperature) within the building structure — Thermoplastics — Recommended practice for installation*
- [22] RAL 840-HR²⁾, *Colour register*

2) Obtainable from national standards institutes.

Draft for comments only — Not to be cited as East African Standard

ICS 83.140.30; 91.140.80

Price based on 30 pages

Draft for comments only — Not to be cited as East African Standard