



CD/K/092-3:2009
ICS 91.140.60; 23.040.45

EAST AFRICAN STANDARD

Plastics piping systems for hot and cold water installations —
Chlorinated poly(vinyl chloride) (PVC-C) — Part 3: Fittings

EAST AFRICAN COMMUNITY

Foreword

Development of the East African Standards has been necessitated by the need for harmonizing requirements governing quality of products and services in East Africa. It is envisaged that through harmonized standardization, trade barriers which are encountered when goods and services are exchanged within the Community will be removed.

In order to meet the above objectives, the EAC Partner States have enacted an East African Standardization, Quality Assurance, Metrology and Test Act, 2006 (EAC SQMT Act, 2006) to make provisions for ensuring standardization, quality assurance, metrology and testing of products produced or originating in a third country and traded in the Community in order to facilitate industrial development and trade as well as helping to protect the health and safety of society and the environment in the Community.

East African Standards are formulated in accordance with the procedures established by the East African Standards Committee. The East African Standards Committee is established under the provisions of Article 4 of the EAC SQMT Act, 2006. The Committee is composed of representatives of the National Standards Bodies in Partner States, together with the representatives from the private sectors and consumer organizations. Draft East African Standards are circulated to stakeholders through the National Standards Bodies in the Partner States. The comments received are discussed and incorporated before finalization of standards, in accordance with the procedures of the Community.

Article 15(1) of the EAC SQMT Act, 2006 provides that "Within six months of the declaration of an East African Standard, the Partner States shall adopt, without deviation from the approved text of the standard, the East African Standard as a national standard and withdraw any existing national standard with similar scope and purpose".

East African Standards are subject to review, to keep pace with technological advances. Users of the East African Standards are therefore expected to ensure that they always have the latest versions of the standards they are implementing.

© East African Community 2010 — All rights reserved*

East African Community

P O Box 1096

Arusha

Tanzania

Tel: 255 27 2504253/8

Fax: 255-27-2504481/2504255

E-Mail: eac@eachq.org

Web: www.each.int

* © 2010 EAC — All rights of exploitation in any form and by any means reserved worldwide for EAC Partner States' NSBs.

Introduction

In the preparation of this East African Standard, the following source was consulted extensively:

ISO 15877-3:2009, *Plastics piping systems for hot and cold water installations — Chlorinated poly(vinyl chloride) (PVC-C) — Part 3: Fittings*

Assistance derived from this source and others inadvertently not mentioned is hereby acknowledged.

Draft for comments only — Not to be cited as East African Standard

**Plastics piping systems for hot and cold
water installations — Chlorinated
poly(vinyl chloride) (PVC-C) —**

**Part 3:
Fittings**

*Systèmes de canalisations en plastique pour les installations d'eau
chaude et froide — Poly(chlorure de vinyle) chloré (PVC-C) —*

Partie 3: Raccords



PDF disclaimer

This PDF file may contain embedded typefaces. In accordance with Adobe's licensing policy, this file may be printed or viewed but shall not be edited unless the typefaces which are embedded are licensed to and installed on the computer performing the editing. In downloading this file, parties accept therein the responsibility of not infringing Adobe's licensing policy. The ISO Central Secretariat accepts no liability in this area.

Adobe is a trademark of Adobe Systems Incorporated.

Details of the software products used to create this PDF file can be found in the General Info relative to the file; the PDF-creation parameters were optimized for printing. Every care has been taken to ensure that the file is suitable for use by ISO member bodies. In the unlikely event that a problem relating to it is found, please inform the Central Secretariat at the address given below.



COPYRIGHT PROTECTED DOCUMENT

© ISO 2009

All rights reserved. Unless otherwise specified, no part of this publication may be reproduced or utilized in any form or by any means, electronic or mechanical, including photocopying and microfilm, without permission in writing from either ISO at the address below or ISO's member body in the country of the requester.

ISO copyright office
Case postale 56 • CH-1211 Geneva 20
Tel. + 41 22 749 01 11
Fax + 41 22 749 09 47
E-mail copyright@iso.org
Web www.iso.org

Published in Switzerland

Contents

	Page
Foreword.....	iv
Introduction	vi
1 Scope	1
2 Normative references	1
3 Terms, definitions and symbols	2
3.1 Terms and definitions.....	2
3.2 Symbols	3
4 Material characteristics	3
4.1 General.....	3
4.2 Fitting material	3
4.3 Evaluation of σ_{LPL}-values	3
4.4 Thermal stability	7
4.5 Metallic material	8
4.6 Influence on water intended for human consumption.....	9
5 General characteristics	9
5.1 Appearance	9
5.2 Opacity	9
6 Geometrical characteristics.....	9
6.1 General.....	9
6.2 Dimensions of fittings	9
6.3 Dimensions of sockets.....	16
6.4 Dimensions of flange adaptors and flanges	18
6.5 Dimensions of metallic fittings.....	20
7 Mechanical characteristics	20
7.1 Resistance to internal pressure	20
7.2 Determination of free lengths.....	21
7.3 Derivation of the hydrostatic test pressure	22
8 Performance requirements	23
9 Adhesives	23
10 Sealing rings	23
11 Marking	24
11.1 General.....	24
11.2 Minimum required marking.....	24
11.3 Additional marking	24
Bibliography	25

Foreword

ISO (the International Organization for Standardization) is a worldwide federation of national standards bodies (ISO member bodies). The work of preparing International Standards is normally carried out through ISO technical committees. Each member body interested in a subject for which a technical committee has been established has the right to be represented on that committee. International organizations, governmental and non-governmental, in liaison with ISO, also take part in the work. ISO collaborates closely with the International Electrotechnical Commission (IEC) on all matters of electrotechnical standardization.

International Standards are drafted in accordance with the rules given in the ISO/IEC Directives, Part 2.

The main task of technical committees is to prepare International Standards. Draft International Standards adopted by the technical committees are circulated to the member bodies for voting. Publication as an International Standard requires approval by at least 75 % of the member bodies casting a vote.

Attention is drawn to the possibility that some of the elements of this document may be the subject of patent rights. ISO shall not be held responsible for identifying any or all such patent rights.

ISO 15877-3 was prepared by the European Committee for Standardization (CEN) Technical Committee CEN/TC 155, *Plastics piping systems and ducting systems*, in collaboration with ISO Technical Committee ISO/TC 138, *Plastics pipes, fittings and valves for the transport of fluids*, Subcommittee SC 2, *Plastics pipes and fittings for water supplies*, in accordance with the Agreement on technical cooperation between ISO and CEN (Vienna Agreement).

This part of ISO 15877 is part of a System Standard for plastics piping systems of a particular material for a specified application. There are a number of such System Standards.

The System Standards are consistent with general standards on functional requirements and recommended practices for installation.

This second edition cancels and replaces the first edition (ISO 15877-3:2003).

ISO 15877 consists of the following parts¹⁾, under the general title *Plastics piping systems for hot and cold water installations — Chlorinated poly(vinyl chloride) (PVC-C)*:

- Part 1: General
- Part 2: Pipes
- Part 3: Fittings
- Part 5: Fitness for purpose of the system
- Part 7: Guidance for the assessment of conformity [Technical Specification]

1) This System Standard does not incorporate a Part 4: *Ancillary equipment* or a Part 6: *Guidance for installation*. For ancillary equipment, separate standards can apply. Guidance for installation of plastics piping systems made from different materials, intended to be used for hot and cold water installations, is covered by ENV 12108^[4].

At the date of publication of this part of ISO 15877, System Standards Series for piping systems of other plastics materials used for the same application are the following:

ISO 15874 (all parts), *Plastics piping systems for hot and cold water installations — Polypropylene (PP)*

ISO 15875 (all parts), *Plastics piping systems for hot and cold water installations — Crosslinked polyethylene (PE-X)*

ISO 15876 (all parts), *Plastics piping systems for hot and cold water installations — Polybutylene (PB)*

ISO 22391:—²⁾ (all parts), *Plastics piping systems for hot and cold water installations — Polyethylene of raised temperature resistance (PE-RT)*

²⁾ To be published. (Revisions of ISO 22391-1:2007, ISO 22391-2:2007, ISO 22391-3:2007, ISO 22391-5:2007.)

Introduction

The System Standard, of which this is Part 3, specifies the requirements for a piping system when made from chlorinated poly(vinyl chloride) (PVC-C). The piping system is intended to be used for hot and cold water installations and for heating system installations.

In respect of potential adverse effects on the quality of water intended for human consumption caused by the product covered by this part of ISO 15877, the following are relevant.

- a) This part of ISO 15877 provides no information as to whether the product may be used without restriction in any of the Member States of the EU or EFTA.
- b) It should be noted that, while awaiting the adoption of verifiable European criteria, existing national regulations concerning the use and/or the characteristics of this product remain in force.

Requirements and test methods for materials and components, other than fittings, are specified in ISO 15877-1 and ISO 15877-2. Characteristics for fitness for purpose (mainly for joints) are covered in ISO 15877-5. ISO/TS 15877-7 gives guidance for the assessment of conformity.

This part of ISO 15877 specifies the characteristics of the fittings.

Plastics piping systems for hot and cold water installations — Chlorinated poly(vinyl chloride) (PVC-C) —

Part 3: Fittings

1 Scope

This part of ISO 15877 specifies the characteristics of fittings made from chlorinated poly(vinyl chloride) (PVC-C) for piping systems intended to be used for hot and cold water installations within buildings for the conveyance of water, whether or not intended for human consumption (domestic systems) and for heating systems under design pressures and temperatures according to the class of application (see Table 1 of ISO 15877-1:2009).

This part of ISO 15877 covers a range of service conditions (application classes) and design pressure classes. For values of T_D , T_{max} and T_{mal} in excess of those in Table 1 of ISO 15877-1:2009, this part of ISO 15877 does not apply.

NOTE 1 It is the responsibility of the purchaser or specifier to make the appropriate selections from these aspects, taking into account their particular requirements and any relevant national regulations and installation practices or codes.

It also specifies the parameters for the test methods referred to in this part of ISO 15877.

In conjunction with the other parts of ISO 15877, it is applicable to PVC-C fittings, their joints and joints with components of PVC-C, other plastics and non-plastics materials intended to be used for hot and cold water installations.

This part of ISO 15877 is applicable to fittings of the following types:

- fittings for solvent cement joints;
- mechanical fittings;
- fittings with incorporated inserts.

NOTE 2 Fittings made from PVC-C are manufactured by injection-moulding.

2 Normative references

The following referenced documents are indispensable for the application of this document. For dated references, only the edition cited applies. For undated references, the latest edition of the referenced document (including any amendments) applies.

ISO 228-1, *Pipe threads where pressure-tight joints are not made on the threads — Part 1: Dimensions, tolerances and designation*

ISO 580, *Plastics piping and ducting systems — Injection-moulded thermoplastics fittings — Methods for visually assessing the effects of heating*

ISO 1167-1, *Thermoplastics pipes, fittings and assemblies for the conveyance of fluids — Determination of the resistance to internal pressure — Part 1: General method*

ISO 1167-2, *Thermoplastics pipes, fittings and assemblies for the conveyance of fluids — Determination of the resistance to internal pressure — Part 2: Preparation of pipe test pieces*

ISO 2536, *Unplasticized polyvinyl chloride (PVC) pressure pipes and fittings, metric series — Dimensions of flanges*

ISO 3126, *Plastics piping systems — Plastics components — Determination of dimensions*

ISO 7686, *Plastics pipes and fittings — Determination of opacity*

ISO 9080, *Plastics piping and ducting systems — Determination of the long-term hydrostatic strength of thermoplastics materials in pipe form by extrapolation*

ISO 15877-1:2009, *Plastics piping systems for hot and cold water installations — Chlorinated poly(vinyl chloride) (PVC-C) — Part 1: General*

ISO 15877-2:2009, *Plastics piping systems for hot and cold water installations — Chlorinated poly(vinyl chloride) (PVC-C) — Part 2: Pipes*

ISO 15877-5, *Plastics piping systems for hot and cold water installations — Chlorinated poly(vinyl chloride) (PVC-C) — Part 5: Fitness for purpose of the system*

EN 681-1, *Elastomeric seals — Material requirements for pipe joint seals used in water and drainage applications — Part 1: Vulcanized rubber*

EN 727, *Plastics piping and ducting systems — Thermoplastics pipes and fittings — Determination of Vicat softening temperature (VST)*

EN 1254-3, *Copper and copper alloys — Plumbing fittings — Part 3: Fittings with compression ends for use with plastics pipes*

EN 10088-1, *Stainless steels — Part 1: List of stainless steels*

EN 10226-1, *Pipe threads where pressure tight joints are made on the threads — Part 1: Taper external threads and parallel internal threads — Dimensions, tolerances and designation*

3 Terms, definitions and symbols

For the purposes of this document, the terms, definitions and symbols given in ISO 15877-1 and the following apply:

3.1 Terms and definitions

3.1.1

fitting for solvent cement joints

fitting in which the joint with the pipe or another component is made by means of an adhesive

3.1.2 Mechanical fittings

3.1.2.1

compression fitting

fitting in which the joint is made by the compression of a ring or sleeve on the outside wall of the pipe with or without additional sealing elements and with internal support

3.1.2.2

flanged fitting

fitting in which the pipe connection consists of two mating flanges, which are mechanically pressed together and sealed by the compression of an elastomeric sealing element between them

3.1.2.3**flat seat union fitting**

fitting in which the pipe connection consists primarily of two components, at least one of which normally incorporates a flat sealing surface, which are mechanically pressed together by means of a screwed nut or similar and sealed by the compression of an elastomeric sealing element between them

3.1.2.4**fitting with incorporated inserts**

fitting in which the joint is made by means of connecting threads or other outlets, inserted in the injection-moulded fitting body, combined with at least one solvent cement socket injection-moulded fitting body, combined with at least one solvent cement socket

3.2 Symbols

d_{s1} inside diameter of the socket at entry

d_{s2} inside diameter of the socket at shoulder

d_1 nominal diameter of the socket

d_2 nominal diameter of the spigot

L socket length

l_0 free length

r bending radius

Z laying length (Z-length)

α_n nominal angle of fitting

4 Material characteristics**4.1 General**

The PVC-C material from which the fittings are made shall conform to this part of ISO 15877 and to the relevant requirements of ISO 15877-1.

4.2 Fitting material

The material from which the fittings are made shall be a chlorinated poly(vinyl chloride) (PVC-C) resin to which are added those additives that are needed to facilitate the manufacture of fittings conforming to this part of ISO 15877.

When tested in accordance with the test method as specified in Table 1 or Table 2, as applicable, using the indicated parameters, test pieces shall withstand the hydrostatic (hoop) stress without bursting or leakage.

4.3 Evaluation of σ_{LPL} -values

The fitting material should be evaluated in accordance with ISO 9080 or equivalent, where an internal pressure test is made in accordance with ISO 1167-1 and ISO 1167-2 to find the σ_{LPL} -values. The σ_{LPL} -values thus determined shall be at least as high as the corresponding values of the reference curves given in Figure 1 and Figure 2 over the complete range of times.

NOTE 1 One equivalent way of evaluation is to calculate the σ_{PL} -values for each temperature (e.g. for 20 °C, 60 °C and 90 °C) individually.

Equation (1) and Equation (2) shall be used to determine the design stress, σ_{DF} , in the fitting material (see Annex A of ISO 15877-2:2009), as well as the values of the hydrostatic stress, σ_F , of the fitting material corresponding to the temperature and time control points given in Table 16 and Table 17.

$$\log t = -121,699 - \frac{25\,985}{T} \times \log \sigma + \frac{47\,143,18}{T} + 63,035\,11 \times \log \sigma \quad (1)$$

$$\log t = -72,662\,4 - \frac{15\,253}{T} \times \log \sigma + \frac{29\,245,14}{T} + 35,54 \times \log \sigma \quad (2)$$

NOTE 2 The reference curves in Figure 1 for PVC-C Type I in the temperature range of 10 °C to 90 °C are derived from Equation (1)

NOTE 3 The reference curves in Figure 2 for PVC-C Type II in the temperature range of 10 °C to 95 °C are derived from Equation (2)

NOTE 4 Resistance to T_{mal} of PVC-C Type I material is verified by testing in accordance with Annex A of ISO 15877-1:2009.

To demonstrate conformance to the reference lines, pipe samples shall be tested at the following temperatures and at various hoop stresses such that, at each of the temperatures given, at least three failure times fall in each of the following time intervals:

- PVC-C Type I: Temperatures 20 °C; 60 °C to 70 °C; 90 °C;
- PVC-C Type I: Time intervals 10 h to 100 h, 100 h to 1 000 h, 1 000 h to 8 760 h and above 8 760 h;
- PVC-C Type II: Temperatures 20 °C; 60 °C to 70 °C; 95 °C;
- PVC-C Type II: Time intervals 10 h to 100 h, 100 h to 1 000 h, 1 000 h to 8 760 h and above 8 760 h;

In tests lasting more than 8 760 h, once no failure is reached at a stress and time at least on or above the reference line, any time after that can be considered as the failure time. Testing should be carried out in accordance with ISO 1167-1.

Design coefficients used for fitting materials are found in Annex A of ISO 15877-2:2009. Conformance to the reference lines should be demonstrated by plotting the individual experimental results on the graph. At least 97,5 % of them should lie on or above the reference line.

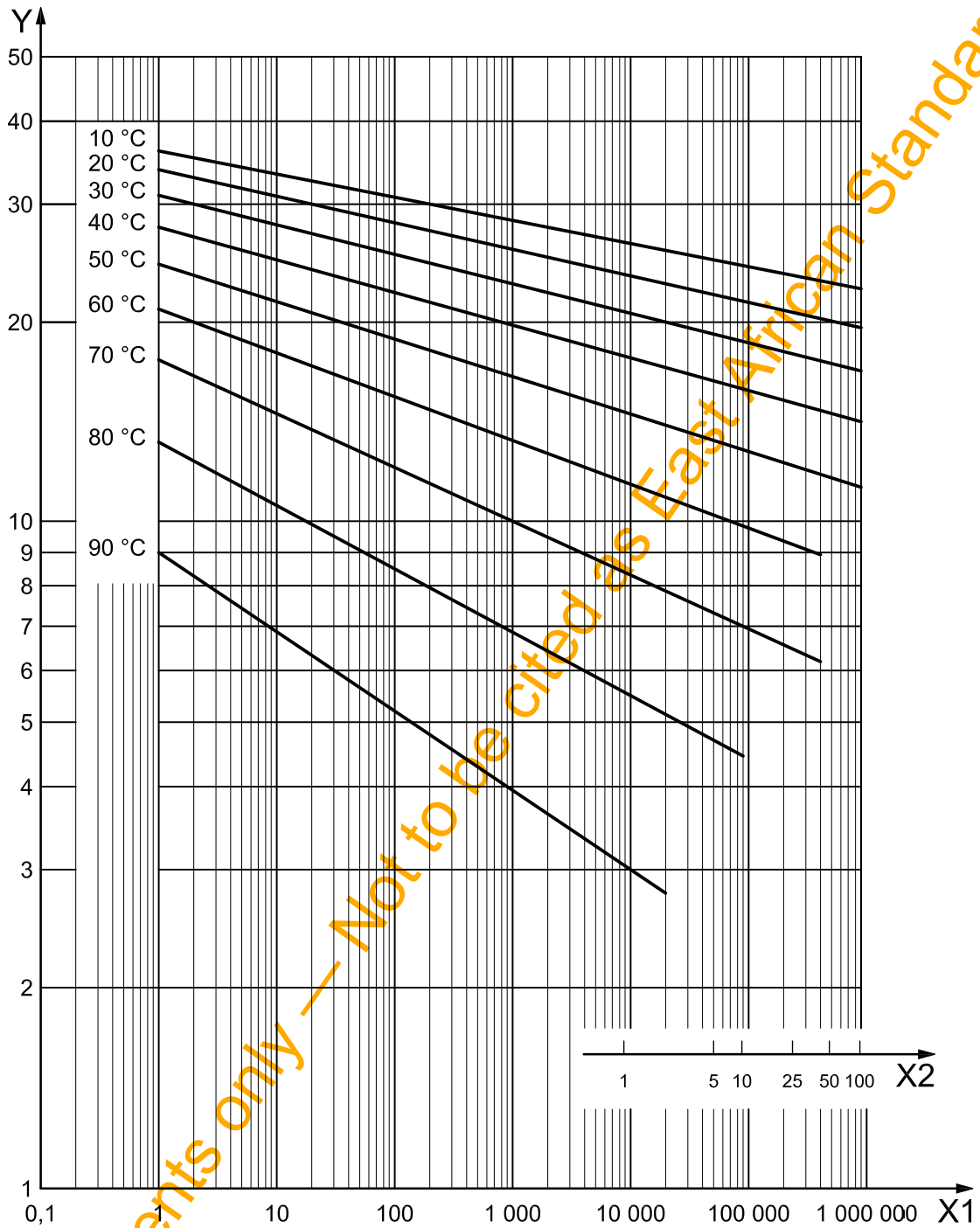

Key

- X1 time to fracture, expressed in hours
- X2 time to fracture, expressed in years
- Y hydrostatic stress, expressed in megapascals

Figure 1 — Reference curves for the expected hydrostatic strength of PVC-C Type I fitting material

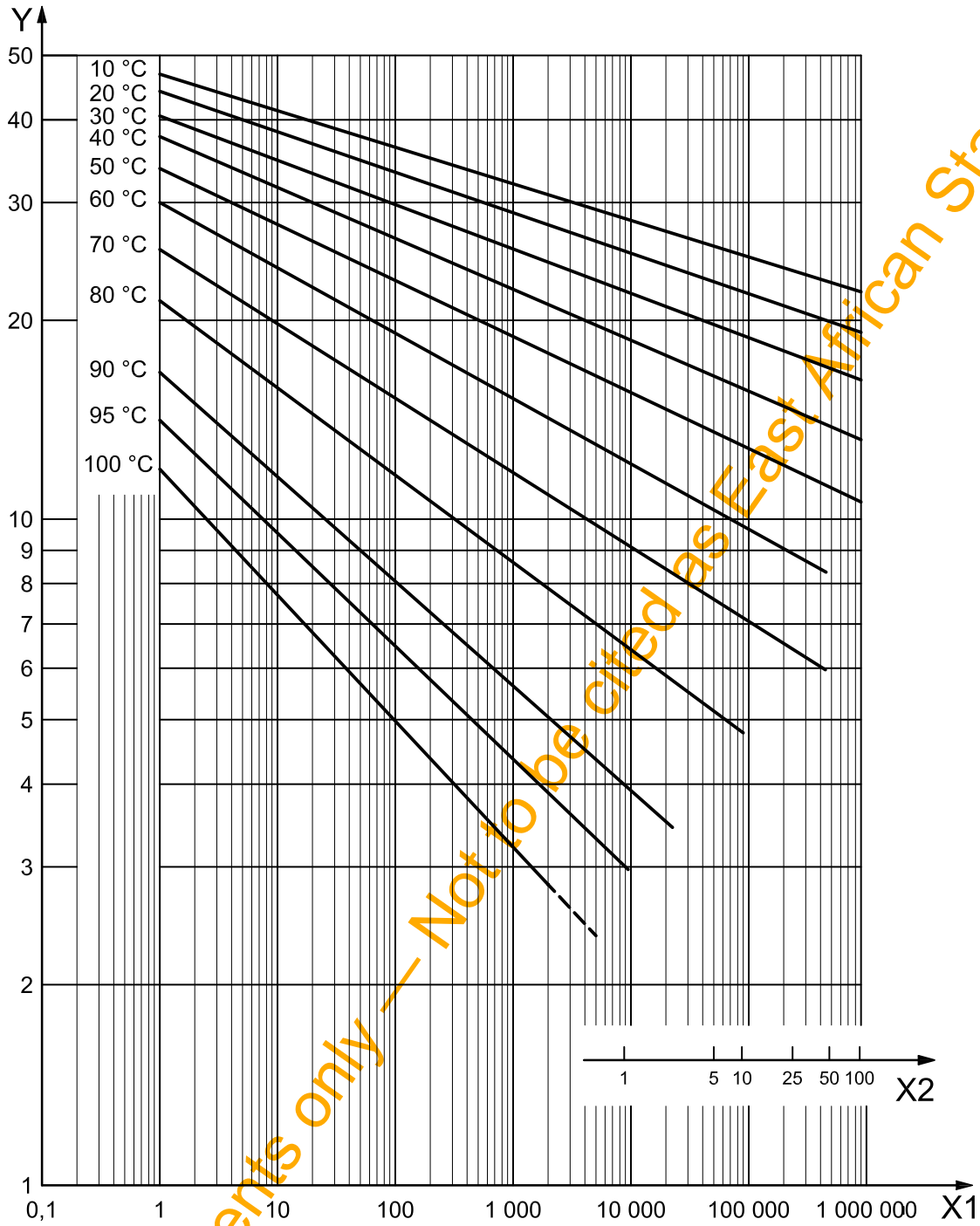

Key

- X1 time to fracture, expressed in hours
- X2 time to fracture, expressed in years
- Y hydrostatic stress, expressed in megapascals

Figure 2 — Reference curves for the expected hydrostatic strength of PVC-C Type II fitting material

4.4 Thermal stability

When tested in accordance with the test methods specified in Table 1 or Table 2, as applicable, using the indicated parameters, the material in tubular form shall have physical characteristics conforming to the requirements given in Table 1 or Table 2, as applicable.

Table 1 — Thermal stability of PVC-C Type I

Characteristic	Requirements	Test parameters		Test method
Vicat softening temperature (VST)	VST \geq 103 °C	Shall conform to EN 727		EN 727
Effects of heating	a b	Test temperature Heating time for: $e \leq 3$ mm $3 \text{ mm} < e \leq 10$ mm $10 \text{ mm} < e \leq 20$ mm Number of test pieces	(150 \pm 2) °C (15 \pm 1) min (30 \pm 1) min (60 \pm 1) min 3	Method A of ISO 580 Air oven
Thermal stability by hydrostatic pressure testing	No bursting or leakage during the test period	Sampling procedure Type of end caps Orientation of test piece Diameter Free length Type of test Test temperature Hydrostatic (hoop) stress Test period Preparation of test pieces Number of test pieces	c Types A or B Vertical $d_n \leq 50$ mm $l_0 \geq 3d_n$ Water-in-air 90 °C 2,85 MPa 17520 h Shall conform to 7.1.2 3	ISO 1167-1
<p>a The fitting shall not show any crack, delamination, blister or sign of weld-line splitting.</p> <p>b No surface damage in the area of any injection point shall penetrate deeper than 20 % of the wall thickness, e, at any point. Outside the area of any injection point, no surface damage shall occur. For sprue gating, the area of the injection point shall be calculated using a radius $R = 0,3d_n$. For fittings moulded by end-gating techniques, e.g. ring or diaphragm methods, the gating area shall be a cylindrical portion with a length of $L = 0,3d_n$ (see Figure 3). Any cracks or delamination in the wall of the fitting adjacent to the injection area, parallel to the axis of the fitting, shall not penetrate to a depth in axial direction of more than 20 % of the nominal diameter.</p> <p>c The sampling procedure is not specified. For guidance, see ISO/TS 15877-7 [3].</p>				

Table 2 — Thermal Stability of PVC-C Type II

Characteristic	Requirements	Test parameters		Test method
Vicat softening temperature (VST)	VST ≥ 115 °C	Shall conform to EN 727		EN 727
Effects of heating	a b	Test temperature Heating time for: $e \leq 3$ mm $3 \text{ mm} < e \leq 10$ mm $10 \text{ mm} < e \leq 20$ mm Number of test pieces	(150 ± 2) °C (15 ± 1) min (30 ± 1) min (60 ± 1) min 3	Method A of ISO 580 Air oven
Thermal stability by hydrostatic pressure testing	No bursting or leakage during the test period	Sampling procedure Type of end caps Orientation of test piece Diameter Free length Type of test Test temperature Hydrostatic (hoop) stress Test period Preparation of test pieces Number of test pieces	c Types A or B Vertical $d_n \leq 50$ mm $l_0 \geq 3d_n$ Water-in-air 100°C 2,14 MPa 8760 h Shall conform to 7.1.2 3	ISO 1167-1

a The fitting shall not show any crack, delamination, blister or sign of weld-line splitting.

b No surface damage in the area of any injection point shall penetrate deeper than 20 % of the wall thickness, e , at any point. Outside the area of any injection point, no surface damage shall occur. For sprue gating, the area of the injection point shall be calculated using a radius $R = 0,3d_n$. For fittings moulded by end-gating techniques, e.g. ring or diaphragm methods, the gating area shall be a cylindrical portion with a length of $L = 0,3d_n$ (see Figure 3). Any cracks or delamination in the wall of the fitting adjacent to the injection area, parallel to the axis of the fitting, shall not penetrate to a depth in axial direction of more than 20 % of the nominal diameter.

c The sampling procedure is not specified. For guidance, see ISO/TS 15877-7 [3].

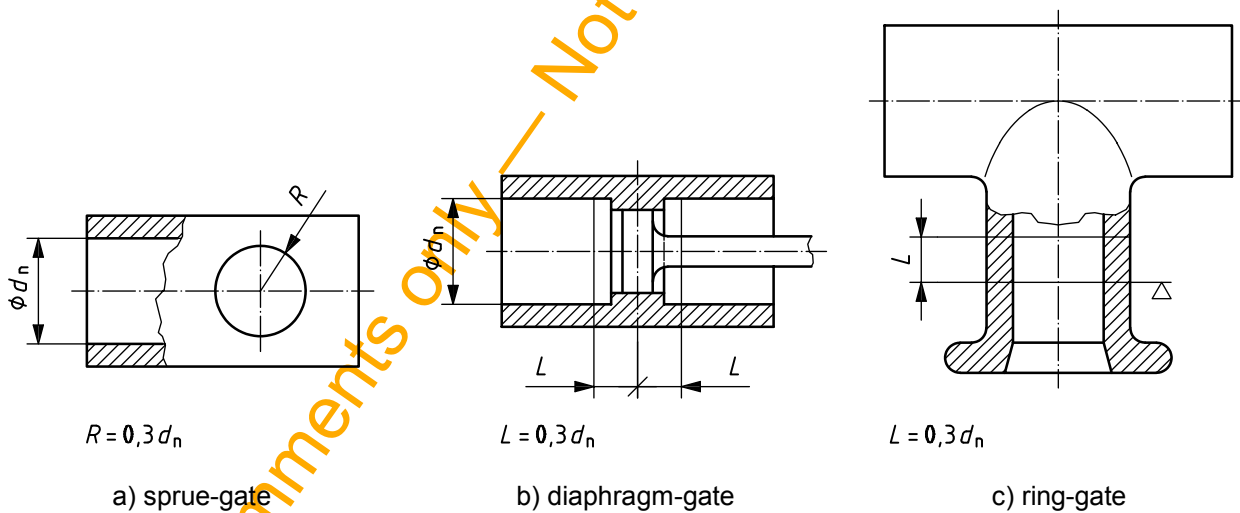

Figure 3 — Injection gating areas

4.5 Metallic material

Metallic material for fittings intended to be used with components conforming to ISO 15877 shall conform to the requirements given in EN 1254-3 or EN 10088-1, as applicable.

4.6 Influence on water intended for human consumption

The material from which the fittings are made shall conform to ISO 15877-1.

5 General characteristics

5.1 Appearance

When viewed without magnification, the internal and external surfaces of fittings shall be smooth, clean and free from scoring, cavities and other surface defects to an extent that would prevent conformance with this part of ISO 15877. The material shall not contain visible impurities. Slight variations in the appearance of the colour shall be permitted.

Each end of a fitting shall be square to its axis.

5.2 Opacity

PVC-C fittings that are declared to be opaque shall not transmit more than 0,2 % of visible light when tested in accordance with ISO 7686.

6 Geometrical characteristics

6.1 General

Dimensions shall be measured in accordance with ISO 3126.

NOTE Figure 4 to Figure 10 cover schematic sketches only, to indicate the relevant dimensions. They do not necessarily represent the manufactured components.

6.2 Dimensions of fittings

6.2.1 Nominal diameter(s)

The nominal diameter(s), d_n , of a fitting shall correspond to and be designated by the nominal outside diameter(s) of the pipe(s) conforming to ISO 15877-2 for which they are designed.

6.2.2 Wall thicknesses

The wall thickness, e , of the fitting body shall conform to Table 3 in relation to the pipe series S.

NOTE Compared with the wall thickness of the corresponding pipe conforming to ISO 15877-2, the wall thickness, e , of the fitting body is increased by the factor 1,35.

Table 3 — Wall thicknesses of fitting bodies

Dimensions in millimetres

Nominal diameter	Pipe series		
	S 6,3	S 5	S 4
d_n	Minimum wall thickness ^a		
	e_{min}		
12	1,9	1,9	1,9
14	1,9	1,9	2,2
16	1,9	2,1	2,5
20	2,1	2,6	3,2
25	2,6	3,2	3,8
32	3,3	4,0	4,9
40	4,1	5,0	6,1
50	5,0	6,3	7,6
63	6,4	7,9	9,6
75	7,6	9,2	11,4
90	9,1	11,1	13,7
110	11,0	13,5	16,7
125	12,5	15,4	18,9
140	14,0	17,2	21,2
160	16,0	19,8	24,2

^a The values are rounded up to the first place of the decimals (i.e. the nearest 0,1 mm).

6.2.3 Angles

The preferred nominal angle, α_n , of non-straight fittings is 45° and 90°.

6.2.4 Threads

Threads used for jointing shall conform to EN 10226-1. Where a thread is used as a fastening thread for jointing an assembly (e.g. union nuts), it shall conform to ISO 228-1 except that these requirements need not apply to the threads used by the manufacturer to join component parts of a fitting together.

6.2.5 Laying lengths (Z-lengths)

For the following types of injection-moulded fittings, the Z-lengths shall be calculated using one of the Equations (3) to (11), as applicable, where α is the angle of the fitting and r is the bending radius:

a) 90° elbow (see Figure 4 and Table 4) $Z = \frac{d_n}{2} + 1$ (3)

b) 45° elbow (see Figure 4 and Table 4) $Z = \left(\frac{d_n}{2} \times \tan \frac{\alpha}{2} \right) + 1$ (4)

c) 90° tee (see Figure 4 and Table 4) $Z = \frac{d_n}{2} + 1$ (3)

d) 45° tee (see Figure 4 and Table 4) $Z = \left(\frac{d_n}{2} \times \cot \frac{\alpha}{2} \right) + t$ (5)

$$Z_1 \approx \left(\frac{d_n}{2} \times \tan \frac{\alpha}{2} \right) + 1 \quad (6)$$

with $d_n \leq 90, 110, 125, 140, 160$ and $t = 3, 4, 6, 6, 7$

e) bends (see Figure 5 and Table 5) $Z \approx r = 2d_n$ (7)

f) reducing bushes, long type (see Figure 6):
 — with conical sockets (see Table 6) $Z_{\text{con}} = 0,3 \times (d_2 - d_1) + L_{d_2}$ (8)

— with cylindrical sockets (see Table 7) $Z_{\text{cyl}} = 0,75 d_2 + 6$ (9)

g) reducing bushes, short type (see Figure 7):
 — with conical sockets (see Table 8) $Z_{\text{con}} = L_{d_2} - L_{d_1}$ (10)

— with cylindrical sockets (see Table 9) $Z_{\text{cyl}} = \left(\frac{d_2}{2} + 6 \right) - \left(\frac{d_1}{2} + 6 \right)$ (11)

The calculated values of the Z-lengths are given in Table 4 to Table 9, as applicable. These values may be adopted by the manufacturer. The manufacturer shall state the exact values for the Z-lengths in his documents (e.g. catalogues).

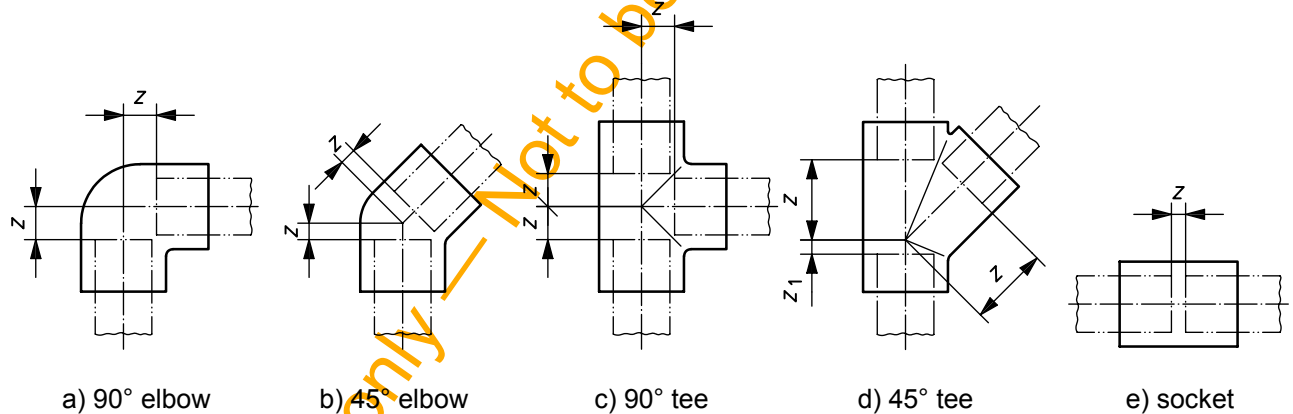

Figure 4 — Z-lengths of elbows, tees and couplers (double-sockets)

Table 4 — Calculated laying lengths (Z-lengths) and related tolerances of elbows, tees and couplers (double-sockets)

Dimensions in millimetres

Nominal diameter d_n	Type of fitting					Double-socket
	90° elbow	45° elbow	90° tee	45° tee		
Calculated Z-length and recommended deviations						
	Z	Z	Z	Z	Z ₁	Z
12	7 ± 1	3,5 ± 1	7 ± 1	—	—	3 ± 1
14	8 ± 1	4 ± 1	8 ± 1	—	—	3 ± 1
16	9 ± 1	4,5 ± 1	9 ± 1	—	—	3 ± 1
20	11 ± 1	5 ± 1	11 ± 1	27 ± 3	6 ⁺² ₋₁	3 ± 1
25	13,5 ^{+1,2} ₋₁	6 ^{+1,2} ₋₁	13,5 ^{+1,2} ₋₁	33 ± 3	7 ⁺² ₋₁	3 ^{+1,2} ₋₁
32	17 ^{+1,6} ₋₁	7,5 ^{+1,6} ₋₁	17 ^{+1,6} ₋₁	42 ⁺⁴ ₋₃	8 ⁺² ₋₁	3 ^{+1,6} ₋₁
40	21 ⁺² ₋₁	9,5 ⁺² ₋₁	21 ⁺² ₋₁	51 ⁺⁵ ₋₃	10 ⁺² ₋₁	3 ⁺² ₋₁
50	26 ^{+2,5} ₋₁	11,5 ^{+2,5} ₋₁	26 ^{+2,5} ₋₁	63 ⁺⁶ ₋₃	12 ⁺² ₋₁	3 ⁺² ₋₁
63	32,5 ^{+3,2} ₋₁	14 ^{+3,2} ₋₁	32,5 ^{+3,2} ₋₁	79 ⁺⁷ ₋₃	14 ⁺² ₋₁	3 ⁺² ₋₁
75	38,5 ⁺⁴ ₋₁	16,5 ⁺⁴ ₋₁	38,5 ⁺⁴ ₋₁	94 ⁺⁹ ₋₃	17 ⁺² ₋₁	4 ⁺² ₋₁
90	46 ⁺⁵ ₋₁	19,5 ⁺⁵ ₋₁	46 ⁺⁵ ₋₁	112 ⁺¹¹ ₋₃	20 ⁺³ ₋₁	5 ⁺² ₋₁
110	56 ⁺⁶ ₋₁	24 ⁺⁶ ₋₁	56 ⁺⁶ ₋₁	137 ⁺¹³ ₋₄	24 ⁺³ ₋₁	6 ⁺³ ₋₁
125	63,5 ⁺⁶ ₋₁	27 ⁺⁶ ₋₁	63,5 ⁺⁶ ₋₁	157 ⁺¹⁵ ₋₄	27 ⁺³ ₋₁	6 ⁺³ ₋₁
140	71 ⁺⁷ ₋₁	30 ⁺⁷ ₋₁	71 ⁺⁷ ₋₁	175 ⁺¹⁷ ₋₅	30 ⁺⁴ ₋₁	8 ⁺³ ₋₁
160	81 ⁺⁸ ₋₁	34 ⁺⁸ ₋₁	81 ⁺⁸ ₋₁	200 ⁺²⁰ ₋₆	35 ⁺⁴ ₋₁	8 ⁺⁴ ₋₁

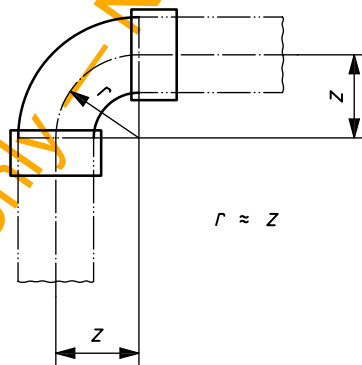

Figure 5 — Dimensions of injection-moulded bends

Table 5 — Calculated laying lengths (Z-lengths) and related tolerances of injection-moulded bends

Dimensions in millimetres

Nominal diameter d_n	Calculated laying length and related tolerances Z	Nominal diameter d_n	Calculated laying length and related tolerances Z
12	24 ± 1	63	$126^{+3,2}_{-1}$
14	28 ± 1	75	150^{+4}_{-1}
16	32 ± 1	90	180^{+5}_{-1}
20	40 ± 1	110	220^{+6}_{-1}
25	$50^{+1,2}_{-1}$	125	250^{+6}_{-1}
32	$64^{+1,6}_{-1}$	140	280^{+7}_{-1}
40	80^{+2}_{-1}	160	320^{+6}_{-1}
50	$100^{+2,5}_{-1}$	—	—

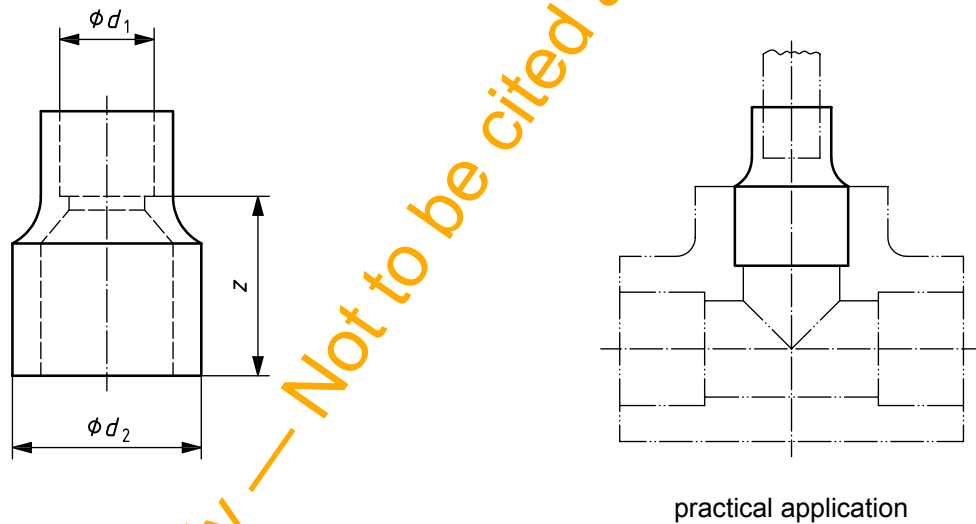

Figure 6 — Dimensions of reducing bushes, long type, and example of application

Table 6 — Calculated laying lengths (Z-lengths) and related tolerances of reducing bushes, long type, with conical sockets

Dimensions in millimetres

Nominal diameter of the socket d_1	Nominal diameter of the spigot, d_2								
	20	25	32	40	50	63	75	90	110
	Calculated laying length, Z, and related tolerances								
	± 1			± 1,5			± 2		
16	21	28	35	—	—	—	—	—	—
20	—	27	34	41	—	—	—	—	—
25	—	—	32	40	49	—	—	—	—
32	—	—	—	38	46	59	—	—	—
40	—	—	—	—	44	57	71	—	—
50	—	—	—	—	—	54	68	84	—
63	—	—	—	—	—	—	64	80	102
75	—	—	—	—	—	—	—	77	99
90	—	—	—	—	—	—	—	—	94

Table 7 — Calculated laying lengths (Z-lengths) and related tolerances of reducing bushes, long type, with cylindrical sockets

Dimensions in millimetres

Nominal diameter of the socket d_1	Nominal diameter of the spigot, d_2											
	20	25	32	40	50	63	75	90	110	125	140	160
	Calculated laying length, Z, and related tolerances											
	± 1			± 1,5			± 2					
14	21	25	30	—	—	—	—	—	—	—	—	—
16	21	25	30	36	—	—	—	—	—	—	—	—
20	—	25	30	36	44	—	—	—	—	—	—	—
25	—	—	30	36	44	54	—	—	—	—	—	—
32	—	—	—	36	44	54	62	—	—	—	—	—
40	—	—	—	—	44	54	62	74	—	—	—	—
50	—	—	—	—	—	54	62	74	88	—	—	—
63	—	—	—	—	—	—	62	74	88	100	—	—
75	—	—	—	—	—	—	—	74	88	100	111	—
90	—	—	—	—	—	—	—	—	88	100	111	126
110	—	—	—	—	—	—	—	—	—	100	111	126
125	—	—	—	—	—	—	—	—	—	—	111	126
140	—	—	—	—	—	—	—	—	—	—	—	126

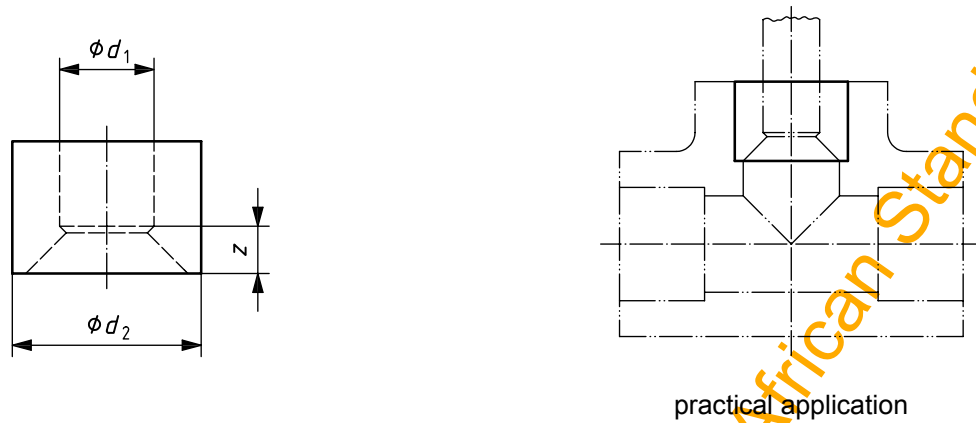

Figure 7 — Dimensions of reducing bushes, short type and example of application

Table 8 — Calculated laying lengths (*Z*-lengths) and related tolerances of reducing bushes, short type, with conical sockets

Dimensions in millimetres

Nominal diameter of the socket d_1	Nominal diameter of the spigot, d_2								
	20	25	32	40	50	63	75	90	110
Calculated laying length, <i>Z</i> , and related tolerances									
	± 1		$\pm 1,5$				± 2		
16	4	9	14	—	—	—	—	—	—
20	—	5	10	15	—	—	—	—	—
25	—	—	5	10	16	—	—	—	—
32	—	—	—	5	11	20	—	—	—
40	—	—	—	—	6	15	25	—	—
50	—	—	—	—	—	9	19	32	—
63	—	—	—	—	—	—	10	22	38
75	—	—	—	—	—	—	—	12	28
90	—	—	—	—	—	—	—	—	16

Table 9 — Calculated laying lengths (Z-lengths) and related tolerances of reducing bushes, short type, with cylindrical sockets

Dimensions in millimetres

Nominal diameter of the socket d_1	Nominal diameter of the spigot, d_2												
	16	20	25	32	40	50	63	75	90	110	125	140	160
	Calculated laying length, Z, and related tolerance ± 1												
14	1	3	5,5	9	—	—	—	—	—	—	—	—	—
16	—	2	4,5	8	12	—	—	—	—	—	—	—	—
20	—	—	2,5	6	10	15	—	—	—	—	—	—	—
25	—	—	—	3,5	7,5	12,5	19	—	—	—	—	—	—
32	—	—	—	—	4	9	15,5	21,5	—	—	—	—	—
40	—	—	—	—	—	5	11,5	17,5	25	—	—	—	—
50	—	—	—	—	—	—	6,5	12,5	20	30	—	—	—
63	—	—	—	—	—	—	—	6	13,5	23,5	31	—	—
75	—	—	—	—	—	—	—	—	7,5	17,5	25	32,5	—
90	—	—	—	—	—	—	—	—	—	10	17,5	25	35
110	—	—	—	—	—	—	—	—	—	—	7,5	15	25
125	—	—	—	—	—	—	—	—	—	—	—	7,5	17,5
140	—	—	—	—	—	—	—	—	—	—	—	—	10

6.3 Dimensions of sockets

6.3.1 Dimensions of cylindrical sockets

The dimensions of cylindrical sockets shall conform to Table 10.

Table 10 — Dimensions of cylindrical sockets

Dimensions in millimetres

Nominal diameter d_n	Mean inside diameter of the socket ^a		Maximum out-of-roundness (ovality)	Minimum socket length L_{min}
	$d_{sm,min}$	$d_{sm,max}$		
12	12,1	12,3	0,25	12
14	14,1	14,3	0,25	13
16	16,1	16,3	0,25	14
20	20,1	20,3	0,25	16
25	25,1	25,3	0,25	18,5
32	32,1	32,3	0,25	22
40	40,1	40,3	0,25	26
50	50,1	50,3	0,3	31
63	63,1	63,3	0,4	37,5
75	75,1	75,3	0,5	43,5
90	90,1	90,3	0,6	51
110	110,1	110,4	0,7	61
125	125,1	125,4	0,8	68,5
140	140,2	140,5	0,9	76
160	160,2	160,5	1,0	86

^a The mean inside diameter of the socket, d_{sm} , shall be measured at the midpoint of the socket. The maximum internal angle of the socketed portion shall not exceed 0°30' (see ISO 727-1 [1] and ISO 727-2 [2]).

6.3.2 Dimensions of conical sockets

The dimensions of conical sockets (see Figure 8) shall conform to Table 11.

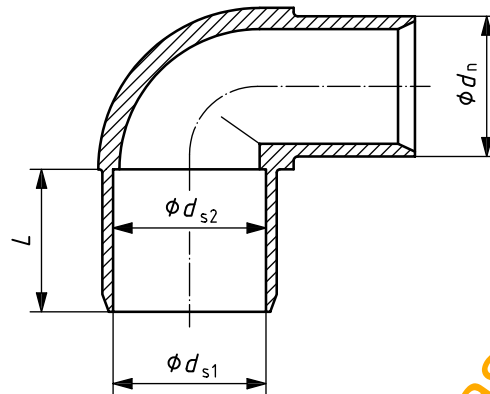

Figure 8 — Dimensions of conical sockets

Table 11 — Dimensions of conical sockets

Dimensions in millimetres

Nominal diameter d_n	Inside diameter of the socket				Maximum out-of-roundness (ovality)	Minimum socket length L_{min}
	at entry		at shoulder			
	$d_{s1,min}$	$d_{s1,max}$	$d_{s2,min}$	$d_{s2,max}$		
12	12,25	12,45	11,9	12,1	0,25	12
14	14,25	14,45	13,9	14,1	0,25	14
16	16,25	16,45	15,9	16,1	0,25	16
20	20,25	20,45	19,9	20,1	0,25	20
25	25,25	25,45	24,9	25,1	0,25	25
32	32,25	32,45	31,9	32,1	0,25	30
40	40,25	40,45	39,8	40,1	0,25	35
50	50,25	50,45	49,8	50,1	0,3	41
63	63,25	63,45	62,8	63,1	0,4	50
75	75,3	75,6	74,75	75,1	0,5	60
90	90,3	90,6	89,75	90,1	0,6	72
110	110,3	110,6	109,75	110,1	0,7	88

6.4 Dimensions of flange adaptors and flanges

6.4.1 Dimensions of flange adaptors

The dimensions of flange adaptors (see Figure 9) shall conform to Table 12.

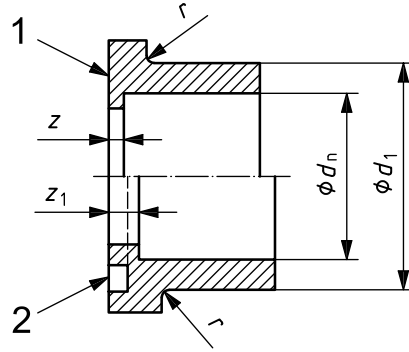

Key

- 1 jointing face for flange gasket
- 2 jointing face with O-ring groove

Figure 9 — Dimensions of flange adaptors

Table 12 — Dimensions of flange adaptors

Dimensions in millimetres

Nominal outside diameter of the corresponding pipe d_n	Outside diameter of chamfer on shoulder d_1	Radius of chamfer on shoulder r_1	Jointing face		Nominal size of the flange ^a DN
			for flat gasket Z	with O-ring groove Z_1	
16	$22 \pm 0,1$	1	3	6	10
20	$27 \pm 0,15$	1	3	6	15
25	$33 \pm 0,15$	1,5	3	6	20
32	$41 \pm 0,2$	1,5	3	6	25
40	$50 \pm 0,2$	2	3	8	32
50	$61 \pm 0,2$	2	3	8	40
63	$76 \pm 0,3$	2,5	3	8	50
75	$90 \pm 0,3$	2,5	3	8	65
90	$108 \pm 0,3$	3	5	10	80
110	$131 \pm 0,3$	3	5	11	100
125	$148 \pm 0,4$	3	5	11	125
140	$165 \pm 0,4$	4	5	11	125
160	$188 \pm 0,4$	4	5	11	150

^a In accordance with ISO 2536.

6.4.2 Dimensions of flanges

The dimensions of flanges (see Figure 10) shall conform to Table 13.

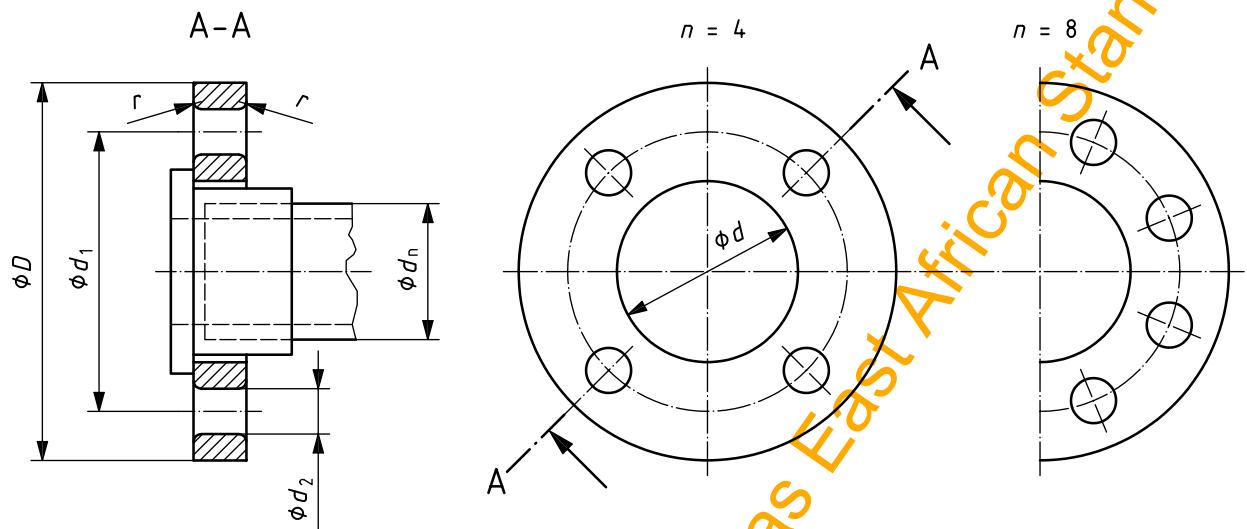

Figure 10 — Dimensions of flanges

Table 13 — Dimensions of flanges

Dimensions in millimetres

Nominal outside diameter of the corresponding pipe	Nominal size of the flange	Outside diameter of the flange	Inside diameter of the flange	Pitch circle diameter of bolt holes	Diameter of bolt holes	Radius	Number of bolt holes	Thread size
d_n	DN	D	d^a	d_1	d_2	r	n	
16	10	90	23	60	14	1	4	M12
20	15	95	28	65	14	1	4	M12
25	20	105	34	75	14	1,5	4	M12
32	25	115	42	85	14	1,5	4	M12
40	32	140	52	100	18	2	4	M16
50	40	150	63	110	18	2	4	M16
63	50	165	78	125	18	2,5	4	M16
75	65	185	92	145	18	2,5	4	M16
90	80	200	110	160	18	3	8	M16
110	100	220	133	180	18	3	8	M16
125	125	250	150	210	18	4	8	M16
140	125	250	167	210	18	4	8	M16
160	150	285	190	240	22	4	8	M20

^a The tolerance for d : $-0,5$ for $d \leq 63$ mm;
 -1 for $d > 63$ mm,
whereby d shall be compatible with the outside diameter, d_1 , of the flange adaptor (see Table 12).

NOTE All joining dimensions conform to ISO 2536.

6.5 Dimensions of metallic fittings

The dimensions and related tolerances of metallic fittings shall correspond to the dimensions of the pipe(s) conforming to ISO 15877-2 for which they are intended to be used.

Metallic fittings shall conform to EN 1254-3.

7 Mechanical characteristics

7.1 Resistance to internal pressure

7.1.1 Testing of material

The material shall be tested in the form of tubular test pieces.

When tested in accordance with the test methods specified in Table 14, using the indicated parameters, the test pieces shall withstand the hydrostatic test pressure, p_F , given in Table 16 or Table 17, as applicable, without bursting or leakage.

Table 14 — Test parameters for testing resistance to internal pressure

Characteristic	Requirements	Test parameters		Test method
Resistance to internal pressure	No failure during the test period	Sampling procedure Type of end caps Orientation of test piece Diameter Free length Test temperature Type of test ^b Test period	^a Types A or B Vertical $d_n \leq 50$ mm $l_0 \geq 3d_n$ Shall conform to Table 16 or Table 17 Water-in-air or water-in-water ^c Shall conform to Table 16 or Table 17	ISO 1167-1
^a The sampling procedure is not specified. For guidance, see ISO/TS 15877-7 ^[3] . ^b Testing at 80 °C (see Table 16 or Table 17) shall be done in water-in-air. ^c In case of dispute, testing at 20 °C shall be done in water-in-water. For temperatures greater than 20 °C, the test shall be done in water-in-air.				

For fittings made from pipes conforming to ISO 15877-2, the requirements on hydrostatic (hoop) stress of the material are regarded as fulfilled.

7.1.2 Testing of fittings

When tested in accordance with ISO 1167-1, using the test parameters given in Table 16 or Table 17, as applicable, the fitting shall withstand the hydrostatic test pressure, p_F , without bursting or leakage during the test period.

For temperatures greater than 20 °C, testing shall be done in water-in-air.

The fittings shall be connected to the corresponding pipe conforming to ISO 15877-2, either by using solvent cement or jointed by mechanical assembly, in such a way that the required hydrostatic test pressure, p_F , given in Table 16 or Table 17, as applicable, can be applied. The free length, l_0 , of the solvent-cemented pipe sections shall be chosen according to Table 15.

Before testing, store the fittings with solvent cemented pipe sections for setting for at least 20 days at ambient temperature and, after that, 4 days at 80 °C, unless the manufacturer of the adhesive has prescribed other setting times.

For fittings with solvent cement joints, the free ends of the pipe sections shall be provided with end caps according to ISO 1167-1 in such a way that the axial forces caused by the internal pressure are transferred to the fitting.

Components comprising parts of an elastomeric ring seal joint, such as union joints, flanged joints and joints with push-fit sockets, shall be tested within the joints.

7.2 Determination of free lengths

In relation to the nominal outside diameter, d_n , of the pipe, the free length, l_0 , shall be chosen according to Table 15.

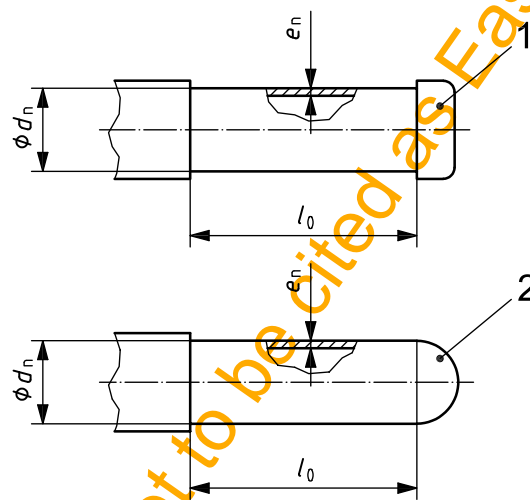

Key

- 1 end cap
- 2 injection moulded end

Figure 11 — Free length of tubular test pieces

Table 15 — Free lengths of solvent cemented pipe sections

Dimensions in millimetres

Nominal outside diameter of the pipe d_n	Free length of the pipe section l_0
≤ 50	150
63 and 75	200
≥ 90	300

For fittings with change in direction (e.g. tees and bends), the free length, l_0 , between the socket mouth of the solvent-cemented pipe and the end cap shall not exceed d_n .

7.3 Derivation of the hydrostatic test pressure

The hydrostatic test pressure, p_F , shall be calculated in relation to the class of service condition and the design pressure, using Equation (12):

$$p_F = p_D \times \frac{\sigma_F}{\sigma_{DF}} \tag{12}$$

where

- p_F is the hydrostatic test pressure, in bar³⁾, to be applied to the fitting during the test period;
- σ_F is the value of the hydrostatic stress, in megapascals, of the fitting material corresponding to the test duration and the test temperature conditions given in Table 16 or Table 17, as applicable;
- σ_{DF} is the design stress value, in megapascals, in the fitting material as determined for the appropriate class of service condition from data produced in accordance with 4.3 and Annex A of ISO 15877-2:2009;
- p_D is the design pressure of 4 bar, 6 bar, 8 bar or 10 bar, as applicable.

Table 16 — Derivation of hydrostatic test pressure for PVC-C Type I

	Class 1			Class 2		
Maximum design temperature T_{max} °C	80			80		
Design stress in the fitting material σ_{DF} MPa	3,17	3,17	3,17	3,08	3,08	3,08
Test temperature^a T_{test} °C	20	60	80	20	60	80
Test duration t h	≥ 1	≥ 1	≥ 3000	≥ 1	≥ 1	≥ 3000
Hydrostatic stress of the fitting material σ_F MPa	33,70	21,07	6,14	33,70	21,07	6,14
Test pressure p_F in bars for a design pressure, p_D , of						
4 bar	42,5	26,6	7,7	43,8	27,4	8,0
6 bar	63,8	39,9	11,6	65,6	41,0	12,0
8 bar	85,0	53,2	15,5	87,5	54,7	15,9
10 bar	106,3	66,5	19,4	109,4	68,4	19,9
Number of test pieces	3	3	3	3	3	3

^a The short-term test is carried out alternatively at 20 °C or 60 °C. In case of dispute, testing shall be done at 60 °C.

3) 1 bar = 0,1 MPa = 0,1 N/mm² = 10⁵ N/m².

Table 17 — Derivation of hydrostatic test pressure for PVC-C Type II

	Class 1			Class 2			Class 4			Class 5		
Maximum design temperature T_{max} °C	80			80			70			90		
Design stress in the fitting material σ_{DF} MPa	3,74	3,74	3,74	3,21	3,21	3,21	4,31	4,31	4,31	2,26	2,26	2,26
Test temperature^a T_{test} °C	20	60	80	20	60	80	20	60	70	20	60	95
Test duration t h	≥ 1	≥ 1	≥ 3 000	≥ 1	≥ 1	≥ 3 000	≥ 1	≥ 1	≥ 3 000	≥ 1	≥ 1	≥ 3 000
Hydrostatic stress of the fitting material σ_F MPa	43,96	29,91	7,44	43,96	29,91	7,44	43,96	29,91	10,46	43,96	29,91	4,78
Test pressure p_F in bars for a design pressure, p_D , of												
4 bar	55,0 ^b	32,0	8,0	55,0 ^b	37,3	9,3	55,0 ^b	27,7	9,7	77,9	53,0	6,4
6 bar	70,6	48,0	12,0	82,2	56,0	13,9	61,2	41,6	14,6	116,9	79,5	9,6
8 bar	94,2	64,1	15,9	109,7	74,6	18,6	81,5	55,5	19,4	155,9	106,0	12,9
10 bar	117,7	80,1	19,9	137,1	93,3	23,2	101,9	69,4	24,3	194,8	132,6	16,1
Number of test pieces	3	3	3	3	3	3	3	3	3	3	3	3
<p>^a The short-term test is carried out alternatively at 20 °C or 60 °C. In case of dispute, testing shall be done at 60 °C.</p> <p>^b The 20 °C, 10 bar, 50 years, cold water requirement, being higher, determines this value.</p>												

8 Performance requirements

When fittings conforming to this part of ISO 15877 are jointed to each other or to pipes conforming to ISO 15877-2, the fittings and the joints shall conform to ISO 15877-5.

9 Adhesives

The adhesive(s) shall be solvent cement and shall be as recommended by the manufacturer of the pipes and/or fittings.

The adhesive(s) shall have no detrimental effects on the properties of the fitting and shall not cause the test assembly to fail to conform to ISO 15877-5.

NOTE Relevant specifications and test methods for solvent cements are currently being discussed by WG 6 *Adhesives for thermoplastic piping systems* of Technical Committee CEN/TC 193 *Adhesives*.

10 Sealing rings

The material of the elastomeric sealing rings used in joint assemblies shall conform to EN 681-1.

The sealing ring(s) shall have no detrimental effects on the properties of the pipes or fittings and shall not cause the test assembly to fail to conform to ISO 15877-5.

11 Marking

11.1 General

Marking elements shall be printed or formed directly on the fitting in such a way that after storage, handling, and installation (see ENV 12108 [4]), legibility is maintained.

NOTE The manufacturer is not responsible for marking being illegible due to actions such as painting, scratching, covering of the components or by use of detergent, etc. on the components unless agreed or specified by the manufacturer.

Marking shall not initiate cracks or other types of defects which adversely influence the performance of the fitting.

If printing is used, the colouring of the printed information shall differ from the basic colouring of the fitting.

The size of the marking shall be such that the marking is legible without magnification.

11.2 Minimum required marking

The minimum required marking of the fitting is specified in Table 18.

Table 18 — Minimum required marking

Aspects ^a	Marking or symbol
- Number of this International Standard	ISO 15877
- Manufacturer's name and/or trade mark ^a	Name or code
- Nominal diameter d_n ^a	e.g. 32
- Nominal wall thickness(es) of the corresponding pipe(s) ^b	e.g. 3,6
- Material ^a	PVC-C
- PVC-C Type I, PVC-C Type II	e.g. PVC-C Type I
- Application class combined with design pressure	e.g. Class 2/10 bar
- Opacity ^c	e.g. opaque
- Manufacturer's information ^a	d

^a These aspects shall be marked on the fitting, except for fittings with $d_n \leq 32$ mm, for which these data may be put on the packaging or a label supplied with the fitting. All other aspects may be marked on the fitting or, alternatively, put onto a label supplied with the fittings.

^b For compression fittings only.

^c If declared by the manufacturer.

^d To provide traceability, the following details shall be given:

- a) the production period, year and month, in figures or in code;
- b) a name or code for the production site if the manufacturer is producing at different sites.

11.3 Additional marking

Fittings conforming to this part of ISO 15877 which are third-party certified may be marked accordingly.

NOTE Attention is drawn to the possible need to include CE marking when required for legislative purposes.

Bibliography

- [1] ISO 727-1, *Fittings made from unplasticized poly(vinyl chloride) (PVC-U), chlorinated poly(vinyl chloride) (PVC-C) or acrylonitrile/butadiene/styrene (ABS) with plain sockets for pipes under pressure — Part 1: Metric series*
- [2] ISO 727-2, *Fittings made from unplasticized poly(vinyl chloride) (PVC-U), chlorinated poly(vinyl chloride) (PVC-C) or acrylonitrile/butadiene/styrene (ABS) with plain sockets for pipes under pressure — Part 2: Inch-based series*
- [3] ISO/TS 15877-7, *Plastics piping systems for hot and cold water installations — Chlorinated poly(vinyl chloride) (PVC-C) — Part 7: Guidance for the assessment of conformity*
- [4] ENV 12108, *Plastics piping systems — Guidance for the installation inside buildings of pressure piping systems for hot and cold water intended for human consumption*

Draft for comments only — Not to be cited as East African Standard

ICS 23.040.45; 91.140.60

Price based on 25 pages

Draft for comments only — Not to be cited as East African Standard