



CD/K/090-3:2009
ICS 91.140.60; 23.040.45

EAST AFRICAN STANDARD

Plastics piping systems for hot and cold water installations —
Crosslinked polyethylene (PE-X) — Part 3: Fittings

EAST AFRICAN COMMUNITY

Foreword

Development of the East African Standards has been necessitated by the need for harmonizing requirements governing quality of products and services in East Africa. It is envisaged that through harmonized standardization, trade barriers which are encountered when goods and services are exchanged within the Community will be removed.

In order to meet the above objectives, the EAC Partner States have enacted an East African Standardization, Quality Assurance, Metrology and Test Act, 2006 (EAC SQMT Act, 2006) to make provisions for ensuring standardization, quality assurance, metrology and testing of products produced or originating in a third country and traded in the Community in order to facilitate industrial development and trade as well as helping to protect the health and safety of society and the environment in the Community.

East African Standards are formulated in accordance with the procedures established by the East African Standards Committee. The East African Standards Committee is established under the provisions of Article 4 of the EAC SQMT Act, 2006. The Committee is composed of representatives of the National Standards Bodies in Partner States, together with the representatives from the private sectors and consumer organizations. Draft East African Standards are circulated to stakeholders through the National Standards Bodies in the Partner States. The comments received are discussed and incorporated before finalization of standards, in accordance with the procedures of the Community.

Article 15(1) of the EAC SQMT Act, 2006 provides that "Within six months of the declaration of an East African Standard, the Partner States shall adopt, without deviation from the approved text of the standard, the East African Standard as a national standard and withdraw any existing national standard with similar scope and purpose".

East African Standards are subject to review, to keep pace with technological advances. Users of the East African Standards are therefore expected to ensure that they always have the latest versions of the standards they are implementing.

© East African Community 2010 — All rights reserved*

East African Community

P O Box 1096

Arusha

Tanzania

Tel: 255 27 2504253/8

Fax: 255-27-2504481/2504255

E-Mail: eac@eachq.org

Web: www.each.int

* © 2010 EAC — All rights of exploitation in any form and by any means reserved worldwide for EAC Partner States' NSBs.

Introduction

In the preparation of this East African Standard, the following source was consulted extensively:

ISO 15875-3:2003, *Plastics piping systems for hot and cold water installations — Crosslinked polyethylene (PE-X) — Part 3: Fittings*

Assistance derived from this source and others inadvertently not mentioned is hereby acknowledged.

Draft for comments only — Not to be cited as East African Standard

INTERNATIONAL
STANDARD

ISO
15875-3

First edition
2003-12-01

**Plastics piping systems for hot and cold
water installations — Crosslinked
polyethylene (PE-X) —**

**Part 3:
Fittings**

*Systèmes de canalisations en plastique pour les installations d'eau
chaude et froide — Polyéthylène réticulé (PE-X) —*

Partie 3: Raccords



Reference number
ISO 15875-3:2003(E)

© ISO 2003

PDF disclaimer

This PDF file may contain embedded typefaces. In accordance with Adobe's licensing policy, this file may be printed or viewed but shall not be edited unless the typefaces which are embedded are licensed to and installed on the computer performing the editing. In downloading this file, parties accept therein the responsibility of not infringing Adobe's licensing policy. The ISO Central Secretariat accepts no liability in this area.

Adobe is a trademark of Adobe Systems Incorporated.

Details of the software products used to create this PDF file can be found in the General Info relative to the file; the PDF-creation parameters were optimized for printing. Every care has been taken to ensure that the file is suitable for use by ISO member bodies. In the unlikely event that a problem relating to it is found, please inform the Central Secretariat at the address given below.

© ISO 2003

All rights reserved. Unless otherwise specified, no part of this publication may be reproduced or utilized in any form or by any means, electronic or mechanical, including photocopying and microfilm, without permission in writing from either ISO at the address below or ISO's member body in the country of the requester.

ISO copyright office
Case postale 56 • CH-1211 Geneva 20
Tel. + 41 22 749 01 11
Fax + 41 22 749 09 47
E-mail copyright@iso.org
Web www.iso.org

Published in Switzerland

Foreword

ISO (the International Organization for Standardization) is a worldwide federation of national standards bodies (ISO member bodies). The work of preparing International Standards is normally carried out through ISO technical committees. Each member body interested in a subject for which a technical committee has been established has the right to be represented on that committee. International organizations, governmental and non-governmental, in liaison with ISO, also take part in the work. ISO collaborates closely with the International Electrotechnical Commission (IEC) on all matters of electrotechnical standardization.

International Standards are drafted in accordance with the rules given in the ISO/IEC Directives, Part 2.

The main task of technical committees is to prepare International Standards. Draft International Standards adopted by the technical committees are circulated to the member bodies for voting. Publication as an International Standard requires approval by at least 75 % of the member bodies casting a vote.

Attention is drawn to the possibility that some of the elements of this document may be the subject of patent rights. ISO shall not be held responsible for identifying any or all such patent rights.

ISO 15875-3 was prepared by the European Committee for Standardization (CEN) in collaboration with Technical Committee ISO/TC 138, *Plastics pipes, fittings and valves for the transport of fluids*, Subcommittee SC 2, *Plastics pipes and fittings for water supplies*, in accordance with the Agreement on technical cooperation between ISO and CEN (Vienna Agreement).

Throughout the text of this document, read “...this European Standard...” to mean “...this International Standard...”.

ISO 15875 consists of the following parts, under the general title *Plastics piping systems for hot and cold water installations — Crosslinked polyethylene (PE-X)*:

- *Part 1: General*
- *Part 2: Pipes*
- *Part 3: Fittings*
- *Part 5: Fitness for purpose of the system*
- *Part 7: Guidance for the assessment of conformity* [Technical Specification]

Contents

Foreword	v
Introduction	vii
1 Scope	1
2 Normative references	1
3 Terms and definitions, symbols and abbreviated terms	2
4 Material characteristics	3
4.1 Plastics fitting material	3
4.1.1 Fitting material identical to PE-X pipe material	3
4.1.2 PE-X fitting material not identical to PE-X pipe material	4
4.1.3 Plastics fitting material other than PE-X.....	4
4.2 Metallic fitting material.....	4
4.3 Influence on water intended for human consumption	4
5 General characteristics	5
5.1 Appearance	5
5.2 Opacity	5
6 Geometrical characteristics	5
6.1 General.....	5
6.1.1 Nominal diameter(s).....	5
6.1.2 Angles	5
6.1.3 Threads	5
6.2 Dimensions of sockets for electrofusion fittings.....	5
6.3 Dimensions of metallic fittings.....	6
7 Mechanical characteristics of plastics fittings	7
7.1 General.....	7
7.2 Fittings made from PE-X material identical to the PE-X pipe material.....	7
7.3 Fittings made from PE-X not identical to the PE-X pipe material	8
7.4 Fittings made from plastics other than PE-X.....	8
8 Physical and chemical characteristics of plastics fittings	8
9 Sealing elements	9
10 Performance requirements	9
11 Marking	9
11.1 General requirements	9
11.2 Minimum required marking.....	9
Bibliography	11

Draft for comments only — Not to be cited as East African Standard

Foreword

This document (EN ISO 15875-3:2003) has been prepared by Technical Committee CEN/TC 155 "Plastics piping systems and ducting systems", the secretariat of which is held by NEN, in collaboration with Technical Committee ISO/TC 138 "Plastics pipes, fittings and valves for the transport of fluids".

This European Standard shall be given the status of a national standard, either by publication of an identical text or by endorsement, at the latest by June 2004, and conflicting national standards shall be withdrawn at the latest by December 2005.

NOTE This draft was submitted for CEN enquiry as prEN 12318-3:1996.

This standard is part of a System Standard for plastics piping systems of a particular material for a specified application. There are a number of such System Standards.

System Standards are based on the results of the work being undertaken in ISO/TC 138 "Plastics pipes, fittings and valves for the transport of fluids", which is a Technical Committee of the International Organisation for Standardization (ISO).

They are supported by separate Standards on test methods to which references are made throughout the System Standard.

The System Standards are consistent with general standards on functional requirements and recommended practices for installation.

EN ISO 15875 consists of the following Parts ¹⁾, under the general title: *Plastics piping systems for hot and cold water installations — Crosslinked polyethylene (PE-X)*

- Part 1: *General*
- Part 2: *Pipes*
- Part 3: *Fittings* (the present standard)
- Part 5: *Fitness for purpose of the system*
- Part 7: *Guidance for the assessment of conformity* (published as CEN ISO/TS 15875-7).

This Part of EN ISO 15875 includes a Bibliography

At the date of publication of this standard, System Standards for piping systems of other plastics materials used for the same application include the following:

EN ISO 15874, *Plastics piping systems for hot and cold water installations — Polypropylene (PP)* (ISO 15874:2003)

EN ISO 15876, *Plastics piping systems for hot and cold water installations — Polybutylene (PB)* (ISO 15876:2003)

EN ISO 15877, *Plastics piping systems for hot and cold water installations — Chlorinated poly(vinyl chloride) (PVC-C)* (ISO 15877:2003)

For pipes and fittings which have conformed to the relevant national standard before 1st November 2003, as shown by the manufacturer or by a certification body, the national standard may continue to apply until 30th November 2005.

¹⁾ This System Standard does not incorporate a Part 4 *Ancillary equipment* or a Part 6 *Guidance for installation*. For ancillary equipment separate standards can apply. Guidance on installation of plastics piping systems made from different materials intended to be used for hot and cold water installations is given by ENV 12108 ^[1].

According to the CEN/CENELEC Internal Regulations, the national standards organizations of the following countries are bound to implement this European Standard: Austria, Belgium, Czech Republic, Denmark, Finland, France, Germany, Greece, Hungary, Iceland, Ireland, Italy, Luxembourg, Malta, Netherlands, Norway, Portugal, Slovakia, Spain, Sweden, Switzerland and the United Kingdom.

Draft for comments only — Not to be cited as East African Standard

Introduction

The System Standard of which this is Part 3, specifies the requirements for a piping system when made from polypropylene (PE-X). The piping system is intended to be used for hot and cold water installations.

In respect of potential adverse effects on the quality of water intended for human consumption, caused by the product covered by this standard:

- This standard provides no information as to whether the product may be used without restriction in any of the Member States of the EU or EFTA;
- It should be noted that, while awaiting the adoption of verifiable European criteria, existing national regulations concerning the use and/or the characteristics of this product remain in force.

Requirements and test methods for materials and components, other than fittings, are specified in Part 1 and Part 2 of EN ISO 15875:2003. Characteristics for fitness for purpose (mainly for joints) are covered in Part 5. Part 7 (CEN ISO/TS 15875-7) gives guidance for the assessment of conformity.

This Part of EN ISO 15875 specifies the characteristics of the fittings.

Draft for comments only — Not to be cited as East African Standard

Draft for comments only — Not to be cited as East African Standard

1 Scope

This Part of EN ISO 15875 specifies the characteristics of fittings for crosslinked polyethylene (PE-X) piping systems intended to be used for hot and cold water installations within buildings for the conveyance of water, whether or not intended for human consumption, (domestic systems) and for heating systems, under design pressures and temperatures appropriate to the class of application (see Table 1 of EN ISO 15875-1:2003).

This standard covers a range of service conditions (application classes) and design pressure classes. For values of T_D , T_{max} and T_{mal} in excess of those in Table 1 of Part 1, this standard does not apply.

NOTE It is the responsibility of the purchaser or specifier to make the appropriate selections from these aspects, taking into account their particular requirements and any relevant national regulations and installation practices or codes.

It also specifies the test parameters for the test methods referred to in this standard.

In conjunction with the other Parts of EN ISO 15875:2003 (see Foreword) it is applicable to fittings made from crosslinked polyethylene (PE-X) and to fittings made from other materials which are intended to be fitted to pipes conforming to EN ISO 15875-2:2003 for hot and cold water installations and whereby the joints conform to the requirements of EN ISO 15875-5.

This standard is applicable to fittings of the following types:

- mechanical fittings;
- electrofusion fittings;
- fittings with incorporated inserts.

2 Normative references

This Standard incorporates by dated or undated reference, provisions from other publications. These normative references are cited at the appropriate places in the text and the publications are listed hereafter. For dated references, subsequent amendments to or revisions of any of these publications apply to this Standard only when incorporated in it by amendment or revision. For undated references the latest edition of the publication referred to applies (including amendments).

EN 578, *Plastics piping systems — Plastics pipes and fittings — Determination of the opacity*

EN 579, *Plastics piping systems — Crosslinked polyethylene (PE-X) pipes — Determination of degree of crosslinking by solvent extraction*

EN 681-1, *Elastomeric seals — Materials requirements for pipe joint seals used in water and drainage applications — Part 1: Vulcanized rubber*

EN 681-2, *Elastomeric seals — Material requirements for pipe joint seals used in water and drainage applications — Part 2: Thermoplastic elastomers*

EN 921:1994, *Plastics piping systems — Thermoplastics pipes — Determination of resistance to internal pressure at constant temperature*

EN 1254-3, *Copper and copper alloys — Plumbing fittings — Part 3: Fittings with compression ends for use with plastics pipes*

EN 10088-1, *Stainless steels — Part 1: List of stainless steels*

prEN 10226-1, *Pipe threads where pressure-tight joints are made on the threads — Part 1: Taper external threads and parallel internal threads — Dimensions, tolerances and designation*

EN 12107, *Plastics piping systems — Injection-moulded thermoplastics fittings, valves and ancillary equipment — Determination of the long-term hydrostatic strength of thermoplastics materials for injection- moulding piping components*

EN ISO 228-1, *Pipe threads where pressure-tight joints are not made on the threads — Part 1: Dimensions, tolerances and designation*

EN ISO 3126, *Plastics piping systems — Plastics components — Determination of dimensions (ISO:2003)*

EN ISO 9080, *Plastics piping and ducting systems — Determination of the long-term hydrostatic strength of thermoplastics materials in pipe form by extrapolation (ISO 9080:2003)*

EN ISO 15875-1:2003, *Plastics piping system for hot and cold water installations — Crosslinked polyethylene (PE-X) — Part 1: General (ISO 15875-1:2002)*

EN ISO 15875-2:2003, *Plastics piping system for hot and cold water installations — Crosslinked polyethylene (PE-X) — Part 2: Pipes (ISO 15875-2:2002)*

EN ISO 15875-5 *Plastics piping system for hot and cold water installations — Crosslinked polyethylene (PE-X) — Part 5: Fitness for purpose of the system (ISO 15875-5:2002)*

ISO 12092, *Fittings, valves and other piping system components made of unplasticized poly(vinyl chloride) (PVC-U), chlorinated poly(vinyl chloride) (PVC-C), acrylonitrile-butadiene-styrene (ABS) and acrylonitrile-styrene-acrylester (ASA) for pipes under pressure — Resistance to internal pressure — Test method*

3 Terms and definitions, symbols and abbreviated terms

For the purposes of this standard, terms and definitions, symbols and abbreviated terms given in EN ISO 15875-1:2003 apply together with the following terms and definitions:

3.1 Mechanical fittings

3.1.1

compression fitting

fitting in which the joint is made by the compression of a ring or sleeve on the outside wall of the pipe with or without additional sealing elements and with internal support

3.1.2

crimped fitting

fitting in which the joint is made by compression of the fitting and/or a ring on the outside wall of the pipe by means of a special tool

3.1.3**flanged fitting**

fitting in which the pipe connection consists of two mating flanges which are mechanically pressed together and sealed by the compression of an elastomeric sealing element between them

3.1.4**flat seat union fitting**

fitting in which the pipe connection consists primarily of two components, at least one of which normally incorporates a flat sealing surface, which are mechanically pressed together by means of a screwed nut or similar and sealed by the compression of an elastomeric sealing element between them

3.2**electrofusion fitting**

fitting in which the joint with the pipe is made by melting together the outer part of the pipe and the inner part of the fitting by means of heat induced by current flowing in an appropriate resistor inserted in the fitting body

3.3**fitting with incorporated inserts**

fitting in which the joints is made by means of connecting threads or other outlets, inserted in the plastics body combined with fusion ends for electrofusion

4 Material characteristics**4.1 Plastics fitting material****4.1.1 Fitting material identical to PE-X pipe material**

The material from which fittings are made shall conform to the requirements as specified for pipes in EN ISO 15875-2:2003.

When tested in accordance with the test method as specified in Table 1 using the indicated parameters, injection moulded tubular test pieces shall withstand the hydrostatic (hoop) stress without bursting or leakage.

Table 1 — Mechanical characteristics of tubular test pieces made of PE-X by injection moulding

Characteristic	Requirement	Test parameters for the individual tests				Test method
		Hydrostatic (hoop) stress	Test temp.	Test period	Number of test pieces	
Resistance to internal pressure	No bursting or leakage during the test period	MPa	°C	h		EN 921:1994 (together with EN 12107)
		12,0	20	1	3	
		4,8	95	1	3	
		4,4	95	1000	3	
		Test parameters for all tests				
Sampling procedure			a			
Type of end cap			Type a)			
Orientation of test piece			Not specified			
Type of test			Water-in -water			
a The sampling procedure is not specified. For guidance see CEN ISO/TS 15875-7 [2].						

4.1.2 PE-X fitting material not identical to PE-X pipe material

4.1.2.1 Evaluation of σ_{LCL} -values and control points

The fitting material in form of injection moulded tubular test pieces shall be evaluated by using the method given in EN ISO 9080 or equivalent where internal pressure tests are made in accordance with EN 921:1994 (together with EN 12107) to find the σ_{LCL} -values. The σ_{LCL} -values thus determined shall be used to determine the design stress, σ_{DF} , (see annex A of EN ISO 15875-2:2003) and values of hydrostatic stress, σ_F , corresponding to the temperature and time control points given in Table 2.

NOTE 1 One equivalent way of evaluation is to calculate the σ_{LCL} -value for each temperature (for example 20 °C, 60 °C and 95 °C) individually.

If evaluation using the method given in EN ISO 9080 or equivalent is available from long-term internal pressure tests relative to extruded pipes of the same compound as used for the fitting, the injection moulded tubular test pieces shall conform to the times for failure at the hydrostatic stress levels for the materials corresponding to the test temperature and the control points given in Table 2.

The relevant test temperature shall be equal to or higher than the maximum design temperature, T_{max} , for the service condition class.

Table 2 — Control points for testing fitting materials with tubular test pieces relative to classification of service conditions

	All application classes	Application class			
		Class 1	Class 2	Class 4	Class 5
Maximum design temperature, T_{max} , in °C		80	80	70	90
Test temperature, T_{Test} , in °C	20	95 ^a	95 ^a	80	95
Test duration, in h	1	1000	1000	1000	1000
^a Conducted at 95 °C to match existing test facilities.					

NOTE 2 It is recommended that the nominal diameter of the injection moulded tubular test pieces should be in the range of the nominal diameter of the fittings normally produced by the manufacturer.

4.1.2.2 Thermal stability

When testing the thermal stability by hydrostatic pressure testing in accordance with EN 921:1994 at 110 °C for 8760 h, using a test piece in pipe form or a fitting connected to pipes, the test piece shall withstand the test without bursting. The test shall be conducted in water-in-air at an internal pressure equivalent to the hydrostatic stress used in the pipe material thermal stability test.

If a fitting connected to pipes is used as a test piece and the pipe connection fails then the thermal stability test shall be repeated using a test piece in pipe form.

4.1.3 Plastics fitting material other than PE-X

Plastics material, other than PE-X, for fittings intended to be used in PE-X piping systems for hot and cold water within buildings for the conveyance of water, whether or not for human consumption (domestic systems) and for heating systems shall conform to 4.1.2.

4.2 Metallic fitting material

Metallic material for fittings intended to be used with components conforming to EN ISO 15875 shall conform to the requirements given in EN 1254-3 or EN 10088-1 as applicable.

4.3 Influence on water intended for human consumption

The material shall conform to EN ISO 15875-1:2003.

5 General characteristics

5.1 Appearance

When viewed without magnification, the internal and external surfaces of fittings shall be smooth, clean and free from scoring, cavities and other surface defects to an extent that would prevent conformance with this standard. The material shall not contain visible impurities. Slight variations in appearance of the colour shall be permitted. Each end of a fitting shall be square to its axis.

5.2 Opacity

Fittings that are declared to be opaque shall not transmit more than 0,2 % of visible light, when tested in accordance with EN 578.

NOTE This test is not necessary when the fitting body material is of the same opaque PE-X compound as the pipe.

6 Geometrical characteristics

6.1 General

Dimensions shall be measured in accordance with EN ISO 3126.

6.1.1 Nominal diameter(s)

The nominal diameter(s), d_n , of a fitting shall correspond to and be designated by the nominal outside diameter(s) of the pipe(s) conforming to EN ISO 15875-2:2003 for which they are designed.

6.1.2 Angles

The preferred nominal angle of non-straight fittings are 45° and 90°.

6.1.3 Threads

Threads used for jointing shall conform to prEN 10226-1. Where a thread is used as a fastening thread for jointing an assembly (e.g. union nuts) it shall conform to EN ISO 228-1 except that these requirements need not apply to the threads used by the manufacturer to join component parts of a fitting together.

6.2 Dimensions of sockets for electrofusion fittings

The principal dimensions of sockets for electrofusion fittings as shown in Figure 1 shall be in accordance with Table 3.

The values of lengths L_1 and L_2 (see Figure 1) shall be in accordance with Table 3. The actual lengths shall be declared by the manufacturer.

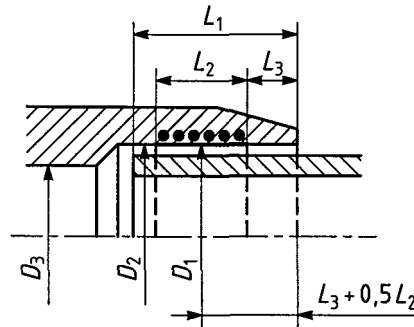

Key

- D_1 is the mean inside diameter in the fusing zone which comprises the mean inside diameter when measured in a plane parallel to the plane of the mouth at a distance of $L_3 + 0,5L_2$ from that face.
- D_2 is the minimum inside diameter of the socket measured in any plane parallel to the plane of the mouth at a distance not greater than L_1 , from that plane.
- D_3 is the minimum bore which comprises the minimum diameter of the flow channel through the body of the fitting.
- L_1 is the depth of penetration of the pipe or male end of a spigot fitting. In the case of a coupling without a stop, it is not greater than half the total length of the fitting.
- L_2 is the nominal length of the fusion zone which comprises the heated length as declared by the manufacturer.
- L_3 is the nominal unheated entrance length of the fitting which comprises the distance between the mouth of the fitting and the start of the fusion zone, as declared by the manufacturer.

Figure 1 — Principal dimensions for electrofusion fittings

Table 3 — Socket dimensions for electrofusion fittings

Dimensions in millimetres

Nominal diameter of the fitting d_n	Minimum mean inside diameter ^a of fusion zone $D_{1,min}$	Nominal length of fusion zone $L_{2,min}$	Depth of penetration	
			$L_{1,min}$	$L_{1,max}$
16	16,1	10	20	35
20	20,1	10	20	37
25	25,1	10	20	40
32	32,1	10	20	44
40	40,1	10	20	49
50	50,1	10	20	55
63	63,2	11	23	63
75	75,2	12	25	70
90	90,2	13	28	79
110	110,3	15	32	85
125	125,3	16	35	90
140	140,3	18	38	95
160	160,4	20	42	101

^a In piping systems which involve spigot trimming smaller values for D_1 are permitted if in conformance with the manufacturer's specification.

6.3 Dimensions of metallic fittings

Metallic fittings shall conform to EN 1254-3.

7 Mechanical characteristics of plastics fittings

7.1 General

When tested in accordance with ISO 12092 using the test parameters given in Table 4, where the test pressure is given in relation to the class of fitting and design pressure, the component shall withstand the test pressure, p_F , without bursting or leakage during the test period.

The testing shall be conducted in water-in-air.

The test pressure shall be calculated using the following equation:

$$p_F = p_D \times \frac{\sigma_F}{\sigma_{DF}}$$

where

p_F is the hydrostatic test pressure, in bars, to be applied to the fitting body during the test period;

σ_F is the value of the hydrostatic stress, in megapascals, of the fitting body material corresponding to the test duration and test temperature conditions in Table 4;

σ_{DF} is the design stress value, in megapascals, of the fitting body material as determined for the appropriate service condition class from data produced in accordance with 4.1 and annex A of EN ISO 15875-2:2003;

p_{Dr} is the design pressure of 4 bar or 6 bar or 8 bar or 10 bar, as applicable.

Fittings may be connected to the pipes for which they are intended to be used. Other methods may be used to seal the ends of the fitting body in order that the required pressure can be applied.

7.2 Fittings made from PE-X material identical to the PE-X pipe material

In this case σ_{DF} has the same value as σ_{DP} and the fitting shall conform to the requirements given in Table 4 using the test pressures, p_F , given, as applicable to the class of fitting and the design pressure.

Table 4 — Derivation of the test pressure p_F

	Application class							
	Class 1		Class 2		Class 4		Class 5	
Max. design temperature, T_{max} , in °C	80		80		70		90	
Design stress of fitting material, σ_{DF} , in MPa	3,85		3,54		4,00		3,24	
Test temperature ^a , T_{test} , in °C	20	95	20	95	20	80	20	95
Test duration, t , in h	1	1000	1	1000	1	1000	1	1000
Hydrostatic stress of fitting material, σ_F , in MPa	12	4,4	12	4,4	12	5,2	12	4,4
Test pressure, p_F , in bars, for a design pressure, p_D , of:								
4 bar	15,8 ^b	5,8 ^b	15,8 ^b	5,8 ^b	15,8 ^b	6,9 ^b	15,8 ^b	5,8 ^b
6 bar	18,7	6,9	20,4	7,5	18,0	7,8	22,3	8,2
8 bar	25,0	9,2	27,2	10,0	24,0	10,4	29,7	10,9
10 bar	31,2	11,5	33,9	12,5	30,0	13,0	37,1	13,6
Number of test pieces	3	3	3	3	3	3	3	3

^a Generally the highest test temperature is taken to be $(T_{max} + 10)$ °C with an upper limit of 95 °C. However to match existing test facilities the highest test temperature for classes 1 and 2 is also set at 95 °C. The hydrostatic stresses given correspond to the given test temperatures.

^b The 20 °C, 10 bar, 50 years requirement, being higher, determines this value (see clause 4 of EN ISO 15875-1:2003).

7.3 Fittings made from PE-X not identical to the PE-X pipe material

The fitting shall conform to the requirements of Table 4 relating to test temperature and minimum time to failure as applicable to the class of fitting and design pressure, using the equation in 7.1 and relevant values for hydrostatic stress, σ_F , and design stress, σ_{DF} , derived as in 4.1.2, to determine the test pressure, p_F .

7.4 Fittings made from plastics other than PE-X

Fittings intended to be used in PE-X piping systems for hot and cold water within for the conveyance of water, whether or not for human consumption (domestic systems) and for heating systems shall conform to 7.3.

8 Physical and chemical characteristics of plastics fittings

When determined in accordance with EN 579, the degree of crosslinking of injection moulded fittings made from crosslinked polyethylene shall conform to Table 5.

Table 5 — Degree of crosslinking

Crosslinking process	Degree of crosslinking
peroxide	≥ 70 %
silane	≥ 65 %
electron beam	≥ 60 %
azo	≥ 60 %

9 Sealing elements

The sealing elements shall have no detrimental effect on the properties of the pipe or fitting and shall not cause the test assembly to fail to conform to EN ISO 15875-5.

The material of the elastomeric sealing elements used in joint assemblies shall conform to EN 681-1 or EN 681-2, as applicable.

10 Performance requirements

When fittings conforming to this standard are jointed to pipes conforming to EN ISO 15875-2:2003, the fitting and the joints shall conform to EN ISO 15875-5.

11 Marking

11.1 General requirements

11.1.1 Marking elements shall be printed or formed directly on the fitting in such a way that after storage, handling, and installation (e.g. in accordance with ENV 12108^[1]), legibility is maintained.

NOTE The manufacturer is not responsible for marking being illegible, due to actions such as painting, scratching, covering of the components or by use of detergent etc. on the components unless agreed or specified by the manufacturer.

11.1.2 Marking shall not initiate cracks or other types of defects, which adversely influence the performance of the fitting.

11.1.3 If printing is used, the colouring of the printed information shall differ from the basic colouring of the fitting.

11.1.4 The size of the marking shall be such that the marking is legible without magnification.

11.2 Minimum required marking

The minimum required marking of the fitting is specified in Table 6.

Table 6 — Minimum marking for fittings

Aspects	Marking or symbol												
Number of this standard	EN 15875												
Manufacturer's name and/or trade mark ^a	Name or code												
Nominal diameter d_n ^a	e.g. 16												
Nominal wall thickness(es) of the corresponding pipe(s) (for compression or crimped fittings only)	e.g. 2,2												
Material identification (for fusion fittings only) ^a	b												
Application class combined with design pressure	e.g. Class 2/10 bar												
Opacity ^c	Opaque												
Manufacturer's information ^a	d												
<p>^a These aspects (where appropriate) must be marked on the fitting. All other aspects may be marked on the fitting or alternatively put on to a label supplied with the fittings.</p> <p>^b For material crosslinked by</p> <table border="0" style="margin-left: 20px;"> <tr><td>peroxide</td><td>: PE-Xa</td></tr> <tr><td>siloxane</td><td>: PE-Xb</td></tr> <tr><td>electron beam</td><td>: PE-Xc</td></tr> <tr><td>azo</td><td>: PE-Xd</td></tr> </table> <p>^c If declared by the manufacturer.</p> <p>^d To provide traceability the following details shall be given:</p> <table border="0" style="margin-left: 20px;"> <tr><td>a)</td><td>the production period, year and month; in figures or in code;</td></tr> <tr><td>b)</td><td>a name or code for the production site if the manufacturer is producing at different sites.</td></tr> </table>		peroxide	: PE-Xa	siloxane	: PE-Xb	electron beam	: PE-Xc	azo	: PE-Xd	a)	the production period, year and month; in figures or in code;	b)	a name or code for the production site if the manufacturer is producing at different sites.
peroxide	: PE-Xa												
siloxane	: PE-Xb												
electron beam	: PE-Xc												
azo	: PE-Xd												
a)	the production period, year and month; in figures or in code;												
b)	a name or code for the production site if the manufacturer is producing at different sites.												

NOTE Attention is drawn to the possible need to include CE marking when required for legislative purposes.

Bibliography

- [1] ENV 12108, *Plastics piping systems — Guidance for the installation inside buildings of pressure piping systems for hot and cold water intended for human consumption*
- [2] CEN ISO/TS 15875-7, *Plastics piping systems for hot and cold water — Crosslinked polyethylene (PE-X) — Part 7: Guidance for the assessment of conformity*

Draft for comments only — Not to be cited as East African Standard

ICS 83.140.30; 91.140.60

Price based on 11 pages

Draft for comments only — Not to be cited as East African Standard