



CD/K/088:2009
ICS 91.140.60; 23.060.30

EAST AFRICAN STANDARD

Predominantly key-operated cast iron gate valves for underground use

Draft for comments only — Not to be cited as East African Standard

EAST AFRICAN COMMUNITY

Foreword

Development of the East African Standards has been necessitated by the need for harmonizing requirements governing quality of products and services in East Africa. It is envisaged that through harmonized standardization, trade barriers which are encountered when goods and services are exchanged within the Community will be removed.

In order to meet the above objectives, the EAC Partner States have enacted an East African Standardization, Quality Assurance, Metrology and Test Act, 2006 (EAC SQMT Act, 2006) to make provisions for ensuring standardization, quality assurance, metrology and testing of products produced or originating in a third country and traded in the Community in order to facilitate industrial development and trade as well as helping to protect the health and safety of society and the environment in the Community.

East African Standards are formulated in accordance with the procedures established by the East African Standards Committee. The East African Standards Committee is established under the provisions of Article 4 of the EAC SQMT Act, 2006. The Committee is composed of representatives of the National Standards Bodies in Partner States, together with the representatives from the private sectors and consumer organizations. Draft East African Standards are circulated to stakeholders through the National Standards Bodies in the Partner States. The comments received are discussed and incorporated before finalization of standards, in accordance with the procedures of the Community.

Article 15(1) of the EAC SQMT Act, 2006 provides that "Within six months of the declaration of an East African Standard, the Partner States shall adopt, without deviation from the approved text of the standard, the East African Standard as a national standard and withdraw any existing national standard with similar scope and purpose".

East African Standards are subject to review, to keep pace with technological advances. Users of the East African Standards are therefore expected to ensure that they always have the latest versions of the standards they are implementing.

© East African Community 2010 — All rights reserved*

East African Community

P O Box 1096

Arusha

Tanzania

Tel: 255 27 2504253/8

Fax: 255-27-2504481/2504255

E-Mail: eac@eachq.org

Web: www.each.int

* © 2010 EAC — All rights of exploitation in any form and by any means reserved worldwide for EAC Partner States' NSBs.

Introduction

In the preparation of this East African Standard, the following source was consulted extensively:

ISO 7259:1988, *Predominantly key-operated cast iron gate valves for underground use*

Assistance derived from this source and others inadvertently not mentioned is hereby acknowledged.

Draft for comments only — Not to be cited as East African Standard

INTERNATIONAL STANDARD

ISO
7259

First edition
1988-12-15



INTERNATIONAL ORGANIZATION FOR STANDARDIZATION
ORGANISATION INTERNATIONALE DE NORMALISATION
МЕЖДУНАРОДНАЯ ОРГАНИЗАЦИЯ ПО СТАНДАРТИЗАЦИИ

Predominantly key-operated cast iron gate valves for underground use

Robinets-vannes en fonte généralement manœuvrés par clé à béquille pour installations enterrées

Reference number
ISO 7259:1988 (E)

Foreword

ISO (the International Organization for Standardization) is a worldwide federation of national standards bodies (ISO member bodies). The work of preparing International Standards is normally carried out through ISO technical committees. Each member body interested in a subject for which a technical committee has been established has the right to be represented on that committee. International organizations, governmental and non-governmental, in liaison with ISO, also take part in the work. ISO collaborates closely with the International Electrotechnical Commission (IEC) on all matters of electrotechnical standardization.

Draft International Standards adopted by the technical committees are circulated to the member bodies for approval before their acceptance as International Standards by the ISO Council. They are approved in accordance with ISO procedures requiring at least 75 % approval by the member bodies voting.

International Standard ISO 7259 was prepared by Technical Committee ISO/TC 153, *Valves*.

Users should note that all International Standards undergo revision from time to time and that any reference made herein to any other International Standard implies its latest edition, unless otherwise stated.

Predominantly key-operated cast iron gate valves for underground use

0 Introduction

The purpose of this International Standard is the establishment of the basic requirements for predominantly key-operated cast iron gate valves for underground use with flanges or spigot ends or socket ends.

1 Scope

This International Standard specifies requirements for two types of predominantly key-operated cast iron gate valves for underground use with flanges or spigot ends or socket ends. The two types of valves shall be specified as type A or type B and shall include the following features :

- inside screw stem (non-rising);
- wedge or double obturator;
- metallic or elastomeric obturator seatings;
- metallic or elastomeric body seatings;
- ferrous metal and/or copper alloy trims;
- T-key operation, see clause 7 and annex A;
- ring key and bar operation, see clause 7 and annex A.

Type A valves are for T-key operation.

Type B valves are for ring key and bar operation.

2 Field of application

2.1 This International Standard deals with valves of the following nominal (DN) sizes :

50; 65; 80; 100; 125; 150; 200; 250; 300

2.2 This International Standard applies to valves of the following nominal (ISO PN) pressure designations :

- 10, 16 and 20 in flake graphite cast iron, and
- 10, 16, 25 and 40 in spheroidal graphite cast iron.

2.3 The dimensions of the valves with spigot ends or socket ends permit these valves to be fitted to

a) Cast iron pipes of DN 50 to DN 300

Valves with spigot ends or socket ends having dimensions in accordance with ISO 2531 and ISO 13 permit these valves to be fitted to cast iron pipes with external diameters in accordance with table 1.

Table 1 — External diameters of cast iron pipes

DN	50	65	80	100	125	150	200	250	300
Outside diameter mm	66	82	98	118	144	170	222	274	326

b) Steel pipes of DN 80 to DN 300

Valves with socket ends having dimensions in accordance with ISO 4200 permit these valves to be fitted to steel pipes with external diameters in accordance with table 2.

Table 2 — External diameters of steel pipes

DN	80	100	125	150	200	250	300
Outside diameter mm	88,9	114,3	139,7	168,3	219,1	273	323,9

The use of these gate valves in piping systems of other materials will be the subject of an agreement between the manufacturer and purchaser.

3 References

ISO 13, *Grey iron pipes, special castings and grey iron parts for pressure main lines.*

ISO 185, *Grey cast iron — Classification.*

ISO 1083, *Spheroidal graphite or nodular graphite cast iron.*

ISO 2531, *Ductile iron pipes, fittings and accessories for pressure pipelines.*

ISO 4200, *Plain end steel tubes, welded and seamless — General tables of dimensions and masses per unit length.*

ISO 5208, *Industrial valves — Pressure testing for valves.*

ISO 5209, *General purpose industrial valves — Marking.*

ISO 5752, *Metal valves for use in flanged pipe systems — Face-to-face and centre-to-face dimensions.*

ISO 7005-2, *Metallic flanges — Part 2 : Cast iron flanges.*

4 Design working pressure

Valves covered by this International Standard shall be designed for maximum permissible gauge working pressures, at ambient temperature, of

- 10 bar (1 MPa) for ISO PN 10 valves;
- 16 bar (1,6 MPa) for ISO PN 16 valves;
- 14 bar (1,4 MPa) for ISO PN 20 valves;
- 25 bar (2,5 MPa) for ISO PN 25 valves;
- 40 bar (4 MPa) for ISO PN 40 valves.

5 Design

5.1 Face-to-face dimensions

5.1.1 Flanged end valves (see figure 1)

The values shown in table 3 apply to unlined type A and type B valves.

Table 3 — Face-to-face dimensions for flake graphite and spheroidal graphite cast iron gate valves ISO PN 10 to ISO PN 40

DN	Face-to-face dimensions mm				
	ISO PN 10/16/20		ISO PN 25		ISO PN 40
50	178	250	216	250	216
65	191	270	241	270	241
80	203	280	283	280	283
100	229	300	305	300	305
125	254	325	381	325	381
150	267	350	403	350	403
200	292	400	419	400	419
250	330	450	457	450	457
300	356	500	502	500	502
Basic series to ISO 5752	3	15	19	15	4

Table 4 — Tolerances on face-to-face dimensions

Dimensions and tolerances in millimetres

Face-to-face dimensions of unlined valves		Tolerances
over	up to and including	
0	250	± 2
250	500	± 3
500	800	± 4

5.1.2 Spigot end and socket end valves (see figures 2 and 3)

Spigot and socket end valves fit directly to the pipes. In accordance with ISO 2531 no dimensions of the sockets and joints are given. The interchangeability of the system components is ensured by standardization of the outside diameters of the spigot ends of pipes and valves. The end-to-end dimensions are not defined for valves with spigot and socket ends.

5.2 Body ends

5.2.1 Flanged body ends

The body flange dimensions for type A and type B valves shall comply with those given in ISO 7005-2.

5.2.2 Spigot or socket ends

Valves may have either spigot or socket ends (see figures 2 and 3). Valves with socket ends may be supplied with various types of socket.

The body ends shall accommodate cast iron pipe with outside diameters as given in table 1 and steel pipe with outside diameters as given in table 2.

NOTE — The standard external diameter of the spigot end of the valves remains the same for all types of joint. The external diameter is the same as that of the spigot end of flake cast iron pipes (see ISO 13), which makes it easier to joint the new ductile iron valves.

5.3 Stem sealing

The stem seal of type A and type B valves may be of the stuffing box and gland form, injector packing form or toroidal sealing rings (O-rings) type or other pressure-actuated types of seal.

If the seal is of the toroidal sealing ring or other pressure-actuated type, the following requirements shall be met :

- a) at least two such seals shall be used;
- b) seals shall be capable of being replaced with the valve under pressure and in the fully open position;

NOTE — The user is warned that there may be some leakage to the atmosphere during this operation.

- c) a dust seal shall be positioned above the seals to prevent ingress of foreign matter.

5.4 Obturator

The obturator design of valves according to this International Standard shall be at the option of the manufacturer.

On wedge seating valves obturators shall be guided so that the obturator seat surface will not contact the body seat until near the point of closure. When wedge seating valves are closed, the discs or wedge shall ride high on the body seats to allow for wear.

5.5 Coatings

All pressure-containing cast iron components shall be thoroughly cleaned and coated externally to provide protection against corrosion. Any internal coating shall be compatible with the fluid passing through the valve in terms of health and safety.

5.6 Requirements for hygiene for internal linings of valves for potable water

Materials used for parts in contact with the water shall not cause toxicity and shall not foster microbiological growth nor give rise to taste, odour, cloudiness or discolouration of the water with which they are, or could be, in contact.

5.7 Number of dead turns

Resilient seated valves shall have a maximum of two stem turns without raising the obturator from the closed position for type A valves and a maximum of one stem turn for type B valves.

6 Materials

The materials of gate valves according to this International Standard are specified in tables 5 and 6.

6.1 Body and bonnet materials

Table 5 — Materials

Type of iron	Grade	Corresponding International Standard
Flake graphite cast iron	25 as a minimum	ISO 185
Spheroidal graphite cast iron	370-17* 400-12* 500-07*	ISO 1083

* At the option of the manufacturer.

6.2 Trim materials

Table 6 shows the materials of the components in three trim categories which are applicable to gate valves according to this International Standard.

7 Operation

Valves shall be operated by a T-key (type A) or ring key and bar (type B) through a false cap, by a handwheel on the top (either directly or via a gearbox) or by actuators.

Valves shall be closed by turning the stem in a clockwise direction unless otherwise specified.

8 Marking

8.1 Every gate valve in accordance with this International Standard shall be legibly marked.

Table 6 — Trim categories

Component	Category A (resilient seated)	Category B (copper alloy faced)	Category C (stainless steel trim)
Obturator with integral faces	Cast iron or copper-alloy	Copper alloy	Stainless steel minimum 11,5 % Cr
Obturator with separate facings	Cast iron	Cast iron	Cast iron
Body seat and obturator facing	Resilient material*	Copper alloy	Stainless steel minimum 11,5 % Cr
Stem	Copper alloy or stainless steel minimum 11,5 % Cr	Copper alloy or stainless steel minimum 11,5 % Cr	Stainless steel minimum 11,5 % Cr
Stem nut	Copper alloy, stainless steel, cast iron : — flake — spheroidal — malleable — austenitic	Copper alloy, stainless steel, cast iron : — flake — spheroidal — malleable — austenitic	Copper alloy, Cu-Ni alloy, cast iron : — flake — spheroidal — malleable — austenitic

* The body seat and obturator facings shall be protected against corrosion.

8.2 Mandatory body markings are as follows (see ISO 5209) :

- nominal size (symbol DN and appropriate value);
- nominal pressure (symbol ISO PN and appropriate value);
- body material identification (ISO designation, see table 8);
- manufacturer's name or trade-mark.

8.3 The trim category, the type of valve (A or B) and the number of this International Standard shall be marked either on the body or on an identification plate (see ISO 5209).

9 Testing and inspection

9.1 Each valve shall be pressure tested in accordance with the requirements of ISO 5208, except that a shell test at 1,5 times the maximum working gauge pressure is mandatory for all valve sizes.

The test fluid used shall be compatible with the fluid passing through the valve in terms of health and safety.

9.2 Valves shall be seat tested in accordance with ISO 5208 and the maximum leakage rates shall be for

- a) metal sealed valves : rate 1;
- b) metal sealed valves : rate 2 or rate 3 (if specified by purchaser);
- c) elastomeric or polymeric sealed valves : rate 3.

9.3 Items shown in table 7 shall be checked on each valve by the manufacturer prior to shipment.

10 Type test

The type test shall be performed by the manufacturer once on each type and size of valves. The test results shall be recorded by the manufacturer and made available, if necessary, to the purchaser.

10.1 Performance type test

Before the performance type test, it is necessary to determine the number of turns of the stem which will accomplish full obturator travel of the particular valve under test.

The valve will, following the strength test (see 10.2), be required to operate through the same number of turns to verify that no damage to component parts has occurred (see 10.4).

10.2 Strength test

The valve shall be so arranged that one end is pressurized to produce a differential pressure on the obturator equivalent to the maximum working pressure of the valve.

The strength test torque as specified in annex A for type A and type B valves shall then be gradually applied to the top end of the valve stem or false cap in both the closed and the fully open positions in order to test the strength of the valve components (see figures 4 to 7).

Under this torque no damage which will render the valve incapable of being operated by the maximum functional test torque specified in annex A shall occur. The presence of such damage will be determined by the functional test detailed in 10.4.

10.3 Pressure test

Following the strength test a pressure test shall be carried out on the shell and seat in accordance with 9.1 and 9.2 respectively.

10.4 Functional test

Following the pressure test the valve shall be fully opened. It shall then be closed using the same number of turns determined before the strength test, with a torque which shall not at any point in its travel exceed the maximum functional test torque specified in annex A.

The valve shall then be fully opened. The torque shall not exceed the maximum functional test torque at any point in the valve travel.

Table 7 – Inspection requirements

Requirements	Test
1 Type and trim The delivered valve shall comply with the order and product standard	Check visually the type, its trim, accessories and other items of the order, for example obturator closed.
2 Marking The marking shall comply with clause 8	Check visually that markings are complete and legible.
3 Surface condition	Examine visually prior to any coating or painting to determine that the surface is free from defects which may affect the safety and function of the valve.
4 Coating	Examine visually to determine that any specified coating has been applied.
5 Operation	Check that the valve opens and closes.

11 Designation

A gate valve manufactured in accordance with this International Standard shall be designated as follows :

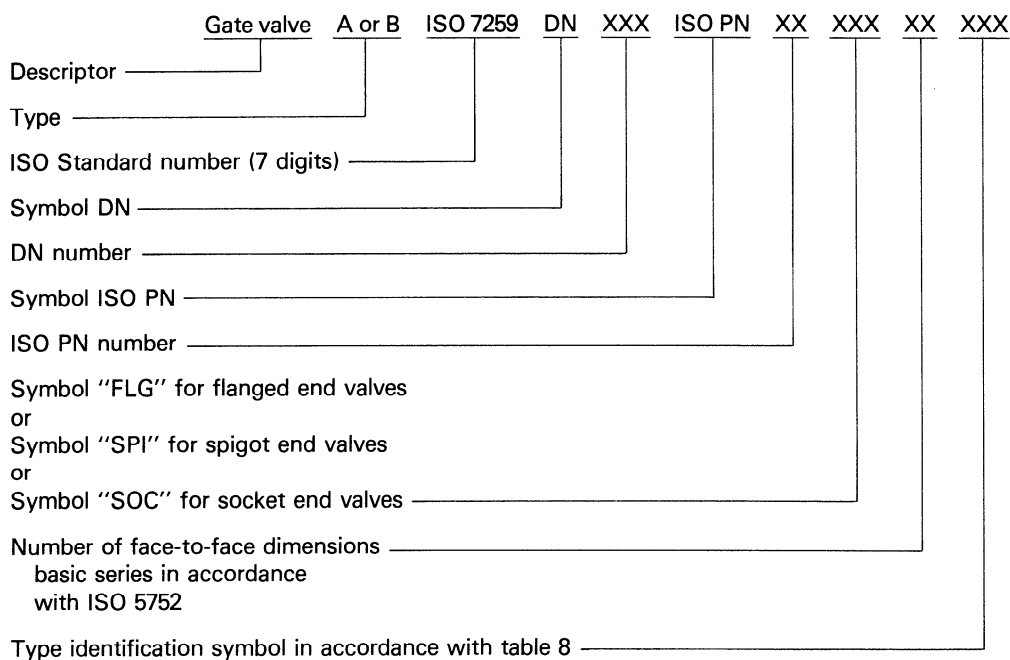

Example :

A gate valve which is T-key operated, of type A, and in conformity with table 9 (symbol A1), and which has a nominal size DN 200, a nominal pressure ISO PN 10, flanged ends (symbol FLG), face-to-face dimensions series 15, resilient seated trim (category A), and a body material of spheroidal cast iron 400-12 (symbol SG-B) shall be designated as follows :

Gate valve A1 ISO 7259 DN 200 ISO PN 10 FLG 15 A SG-B

Table 8 – Type identification symbols

Identification symbols	Type	Type A	(see table 9)	A1	
			(see table 10)	A2	
		Type B		B	
	Trim category		Resilient seated		A
			Copper alloy faced		B
			Stainless steel		C
	Body material		Flake graphite		CI
		Spheroidal cast iron grade		370-17	SG-A
				400-12	SG-B
			500-7	SG-C	

12 Preparation for despatch

12.1 After testing, each valve shall be drained and prepared for despatch.

12.2 All valve obturators shall be in the closed position when despatched (except resilient seated valves which shall preferably be in the open position), unless otherwise specified by the purchaser.

12.3 When specified by the purchaser, body ends shall be covered with wood, wood fibre, plastic or metal covers. Covers of flanged valves shall extend over the entire flange gasket face.

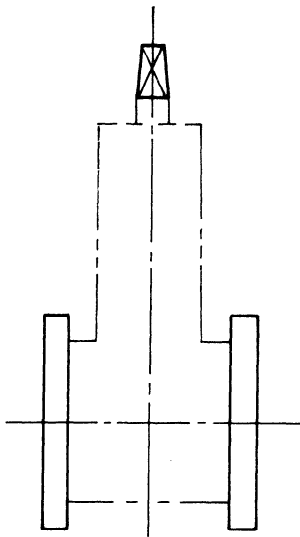

Figure 1 — Flanged end valve

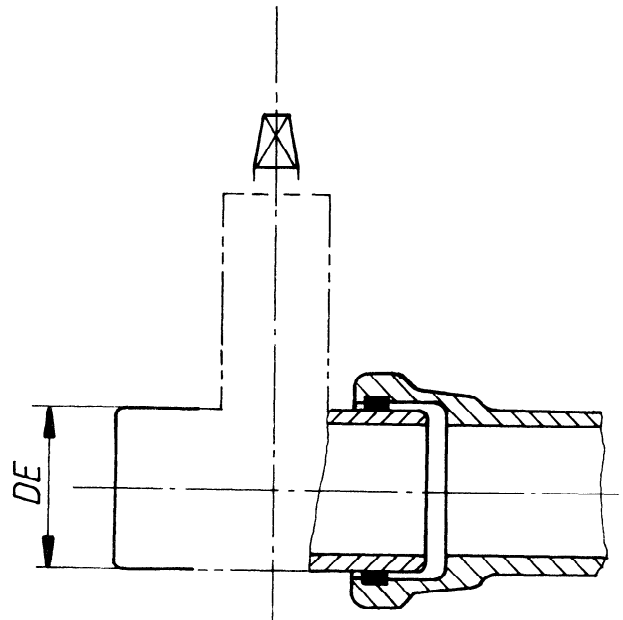

Figure 2 — Spigot end valve

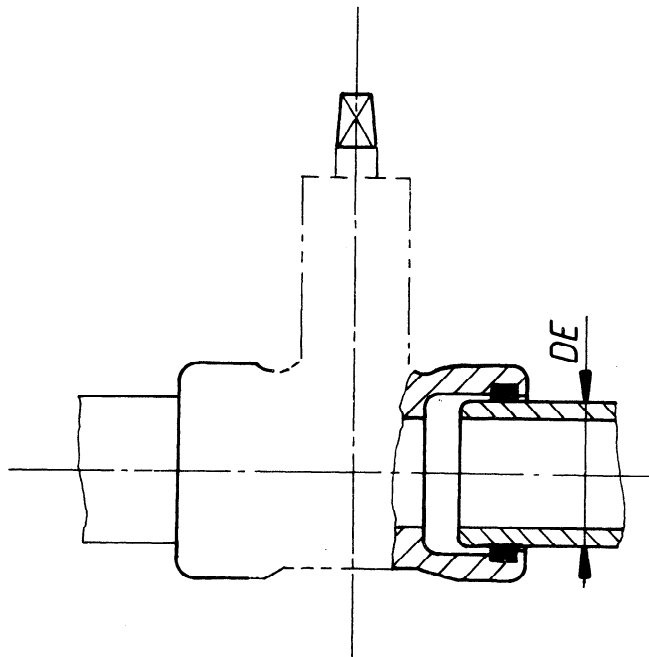

Figure 3 — Socket end valve

Annex A

Test torques and test set-ups

(This annex forms an integral part of the standard.)

A.1 Test torques

A.1.1 T-key operation

The test torques for type A1 and A2 valves are specified in tables 9 and 10. The maximum functional test torques and the strength test torques of table 9 may be replaced by the input torques for strength test given in table 10; either series of torque tests are equally valid for compliance with this International Standard (see figures 4 and 6).

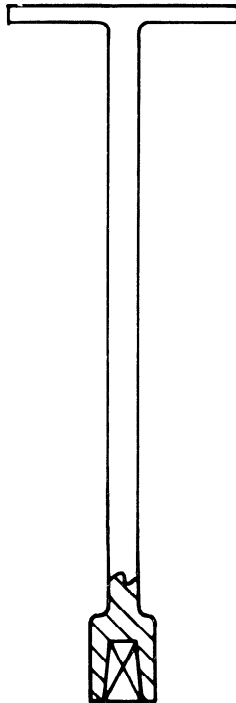

Figure 4 — T-key operation*

Table 9 — Test torque for T-key operated valves, type A1

DN	Maximum functional test torque N·m	Strength test torque N·m
50	60	180
65	75	225
80	75	225
100	100	300
125	125	375
150	150	450
200	200	600
250	250	750
300	300	900

Table 10 — Input torque for strength test for T-key operated valves, type A2

DN	Input torque N·m
80	270
100	270
150	400
200	400
250	400
300	400

* Schematic representation.

A.1.2 Ring key and bar operation

The test torques for type B valves operated by a ring key and bar in combination with a stem having a thread lead of 12 mm are specified in table 11 (see figures 5 and 7).

Table 11 — Test torque for ring key and bar operated valves with 12 mm stem lead thread

DN	Maximum functional test torque N·m	Strength ¹⁾ test torque N·m
50	175	500
65	200	600
80	250	750
100	300	800
125	350	1 000
150	400	1 200
200	500	1 500
250	600	1 800
300	600	1 800

1) This test shall include simultaneously a bending moment of 1 500 N·m at the false cap.

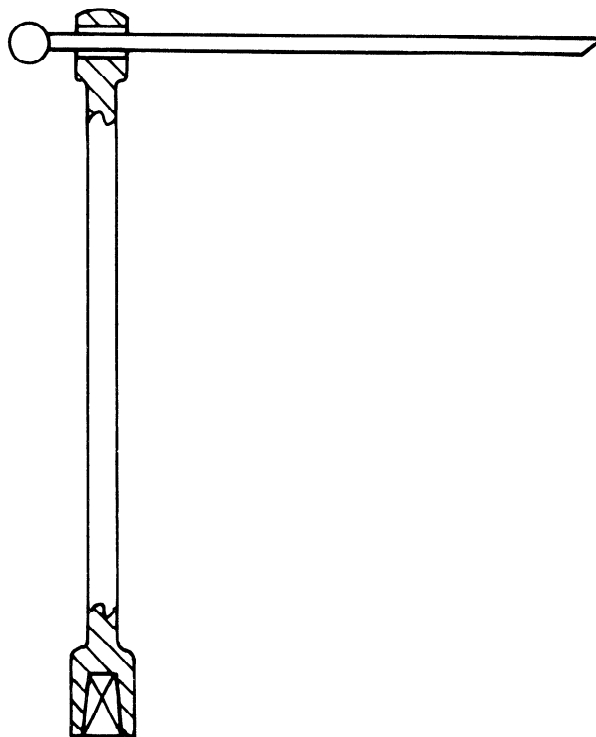

Figure 5 — Ring key and bar operation*

* Schematic representation.

A.2 Test set-ups

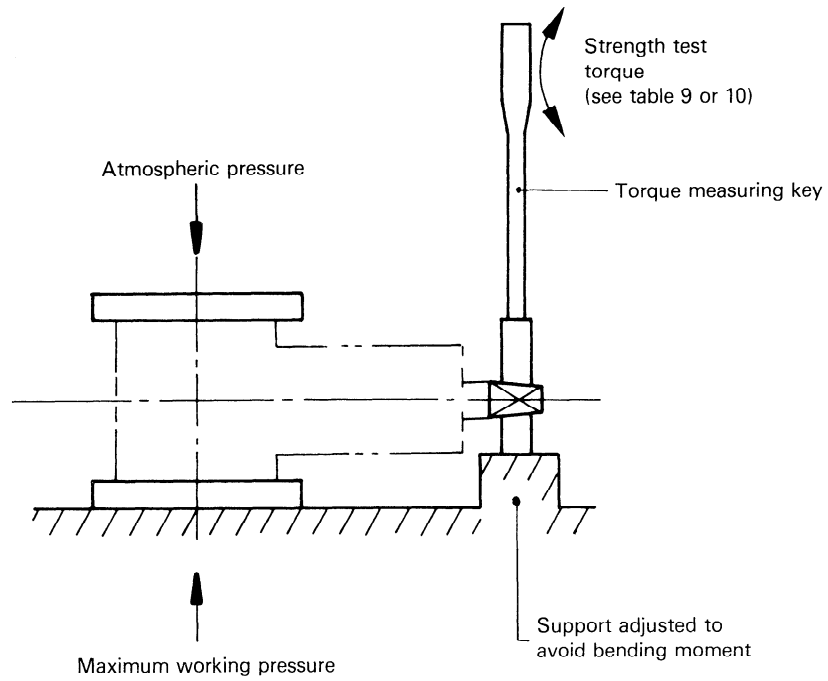
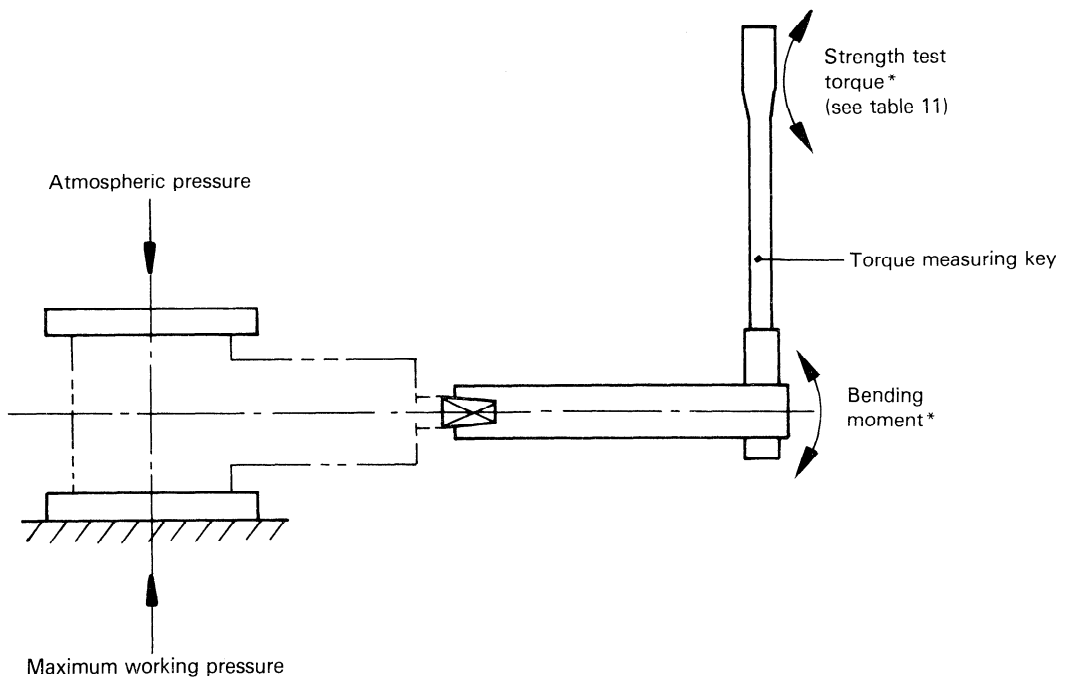

Figure 6 — Strength test for T-key operated valves, types A1 and A2



* The bending moment and strength test torque shall be applied simultaneously.

Figure 7 — Strength test for ring key and bar operated valves, type B

Annex B

Bibliography

(This annex does not form an integral part of the standard.)

ISO 2084, *Pipeline flanges for general use — Metric series — Mating dimensions.*

ISO 2229, *Equipment for the petroleum and natural gas industries — Steel pipe flanges, nominal sizes 1/2 to 24 in — Metric dimensions.*

ISO 2441, *Pipeline flanges for general use — Shapes and dimensions of pressure-tight surfaces.*

ISO 5210-1, *Multi-turn valve actuator attachment — Part 1 : Flange dimensions.*

ISO 5210-2, *Multi-turn valve actuator attachment — Part 2 : Flange and coupling performance characteristics.*

ISO 6708, *Pipe components — Definition of nominal size.*

ISO 7268, *Pipe components — Definition of nominal pressure.*

UDC 621.646.5-034.13

Descriptors : cast iron products, valves, gate valves, specifications, dimensions, materials, designation, marking.

Price based on 10 pages

Draft for comments only — Not to be cited as East African Standard