



EAST AFRICAN STANDARD

Plastics piping systems for pressure and non-pressure water supply — Glass-reinforced thermosetting plastics (GRP) systems based on unsaturated polyester (UP) resin

EAST AFRICAN COMMUNITY

Foreword

Development of the East African Standards has been necessitated by the need for harmonizing requirements governing quality of products and services in East Africa. It is envisaged that through harmonized standardization, trade barriers which are encountered when goods and services are exchanged within the Community will be removed.

In order to meet the above objectives, the EAC Partner States have enacted an East African Standardization, Quality Assurance, Metrology and Test Act, 2006 (EAC SQMT Act, 2006) to make provisions for ensuring standardization, quality assurance, metrology and testing of products produced or originating in a third country and traded in the Community in order to facilitate industrial development and trade as well as helping to protect the health and safety of society and the environment in the Community.

East African Standards are formulated in accordance with the procedures established by the East African Standards Committee. The East African Standards Committee is established under the provisions of Article 4 of the EAC SQMT Act, 2006. The Committee is composed of representatives of the National Standards Bodies in Partner States, together with the representatives from the private sectors and consumer organizations. Draft East African Standards are circulated to stakeholders through the National Standards Bodies in the Partner States. The comments received are discussed and incorporated before finalization of standards, in accordance with the procedures of the Community.

Article 15(1) of the EAC SQMT Act, 2006 provides that "Within six months of the declaration of an East African Standard, the Partner States shall adopt, without deviation from the approved text of the standard, the East African Standard as a national standard and withdraw any existing national standard with similar scope and purpose".

East African Standards are subject to review, to keep pace with technological advances. Users of the East African Standards are therefore expected to ensure that they always have the latest versions of the standards they are implementing.

© East African Community 2010 — All rights reserved*

East African Community

P O Box 1096

Arusha

Tanzania

Tel: 255 27 2504253/8

Fax: 255-27-2504481/2504255

E-Mail: eac@eacho.org

Web: www.each.int

* © 2010 EAC — All rights of exploitation in any form and by any means reserved worldwide for EAC Partner States' NSBs.

Introduction

In the preparation of this East African Standard, the following source was consulted extensively:

ISO 10639:2004, *Plastics piping systems for pressure and non-pressure water supply — Glass-reinforced thermosetting plastics (GRP) systems based on unsaturated polyester (UP) resin*

Assistance derived from this source and others inadvertently not mentioned is hereby acknowledged.

Draft for comments only — Not to be cited as East African Standard

Plastics piping systems for pressure and non-pressure water supply — Glass-reinforced thermosetting plastics (GRP) systems based on unsaturated polyester (UP) resin

Systèmes de canalisation en matières plastiques pour l'alimentation en eau avec ou sans pression — Systèmes en plastiques thermodurcissables renforcés de verre (PRV) à base de résine de polyester non saturé (UP)



PDF disclaimer

This PDF file may contain embedded typefaces. In accordance with Adobe's licensing policy, this file may be printed or viewed but shall not be edited unless the typefaces which are embedded are licensed to and installed on the computer performing the editing. In downloading this file, parties accept therein the responsibility of not infringing Adobe's licensing policy. The ISO Central Secretariat accepts no liability in this area.

Adobe is a trademark of Adobe Systems Incorporated.

Details of the software products used to create this PDF file can be found in the General Info relative to the file; the PDF-creation parameters were optimized for printing. Every care has been taken to ensure that the file is suitable for use by ISO member bodies. In the unlikely event that a problem relating to it is found, please inform the Central Secretariat at the address given below.

© ISO 2004

All rights reserved. Unless otherwise specified, no part of this publication may be reproduced or utilized in any form or by any means, electronic or mechanical, including photocopying and microfilm, without permission in writing from either ISO at the address below or ISO's member body in the country of the requester.

ISO copyright office
Case postale 56 • CH-1211 Geneva 20
Tel. +41 22 749 01 11
Fax +41 22 749 09 47
E-mail copyright@iso.org
Web www.iso.org

Published in Switzerland

Contents

Page

Foreword.....	iv
1 Scope.....	1
2 Normative references	2
3 Terms and definitions	3
4 General	13
4.1 Classification.....	13
4.2 Materials.....	14
4.3 Wall construction	15
4.4 Appearance.....	16
4.5 Reference conditions for testing.....	16
4.6 Elapsed time, x , for determination of long-term properties.....	16
4.7 Joints.....	16
4.8 Effect on water quality.....	17
5 Pipes.....	18
5.1 Geometrical characteristics.....	18
5.2 Mechanical characteristics	25
5.3 Resistance of pressure pipes to cyclic internal pressure	35
5.4 Marking.....	35
6 Fittings	36
6.1 All types	36
6.2 Bends	37
6.3 Branches	42
6.4 Reducers.....	45
6.5 Saddles.....	49
6.6 Flanged adaptors	50
6.7 Marking.....	53
7 Joint performance.....	54
7.1 General.....	54
7.2 Flexible joints	54
7.3 Rigid joints.....	57
Annex A (normative) Principles used to establish the design requirements based on regression testing and consideration of the variability of the product	63
Annex B (informative) Guidance on leaktightness testing.....	71

Foreword

ISO (the International Organization for Standardization) is a worldwide federation of national standards bodies (ISO member bodies). The work of preparing International Standards is normally carried out through ISO technical committees. Each member body interested in a subject for which a technical committee has been established has the right to be represented on that committee. International organizations, governmental and non-governmental, in liaison with ISO, also take part in the work. ISO collaborates closely with the International Electrotechnical Commission (IEC) on all matters of electrotechnical standardization.

International Standards are drafted in accordance with the rules given in the ISO/IEC Directives, Part 2.

The main task of technical committees is to prepare International Standards. Draft International Standards adopted by the technical committees are circulated to the member bodies for voting. Publication as an International Standard requires approval by at least 75 % of the member bodies casting a vote.

Attention is drawn to the possibility that some of the elements of this document may be the subject of patent rights. ISO shall not be held responsible for identifying any or all such patent rights.

ISO 10639 was prepared by Technical Committee ISO/TC 138, *Plastics pipes, fittings and valves for the transport of fluids*, Subcommittee SC 6, *Reinforced plastics pipes and fittings for all applications*.

Plastics piping systems for pressure and non-pressure water supply — Glass-reinforced thermosetting plastics (GRP) systems based on unsaturated polyester (UP) resin

1 Scope

This International Standard specifies the properties of piping system components made from glass-reinforced thermosetting plastics (GRP) based on unsaturated polyester resin (UP) for water supply with or without pressure, as well as the properties of the system itself.

This International Standard is applicable to GRP-UP piping systems, with flexible or rigid joints with or without end thrust load-bearing capability, primarily intended for use in buried installations.

NOTE Piping systems conforming to this International Standard can also be used for non-buried applications provided the influence of the environment and the supports are considered in the design of the pipes, fittings and joints.

This International Standard is applicable to pipes, fittings and their joints of nominal sizes from DN 50 to DN 4000 which are intended to be used for the conveyance of water at temperatures up to 50 °C, with or without pressure. In a pipework system, pipes and fittings of different nominal pressure and stiffness ratings may be used together.

Clause 4 specifies the general aspects of GRP-UP piping systems intended to be used in the field of water supply with or without pressure.

Clause 5 specifies the characteristics of pipes made from GRP-UP with or without aggregates and/or fillers. The pipes may have a thermoplastics or thermosetting resin liner. Clause 5 also specifies the test parameters for the test methods referred to in this International Standard.

Clause 6 specifies the characteristics of fittings made from GRP-UP, with or without a thermoplastics or thermosetting resin liner, intended to be used in the field of water supply. Clause 6 specifies the dimensional and performance requirements for bends, branches, reducers, saddles and flanged adaptors. Clause 6 is applicable to fittings made using any of the following techniques:

- a) fabrication from straight pipes;
- b) moulding by
 - 1) filament winding,
 - 2) tape winding,
 - 3) contact moulding,
 - 4) hot or cold compression moulding.

Clause 7 is applicable to the joints to be used in GRP-UP piping systems to be used for the conveyance of water, both buried and non-buried. It covers requirements to prove the design of the joint. Clause 7 specifies type test performance requirements for the following joints as a function of the declared nominal pressure rating of the pipeline or system:

- a) socket-and-spigot (including double-socket) joints or mechanical joints;
- b) locked socket-and-spigot joints;
- c) cemented or wrapped joints;
- d) bolted flange joints.

2 Normative references

The following referenced documents are indispensable for the application of this document. For dated references, only the edition cited applies. For undated references, the latest edition of the referenced document (including any amendments) applies.

ISO 75-2:2003, *Plastics — Determination of temperature of deflection under load — Part 2: Plastics and ebonite*

ISO 161-1, *Thermoplastics pipes for the conveyance of fluids — Nominal outside diameters and nominal pressures — Part 1: Metric series*

ISO 527-4, *Plastics — Determination of tensile properties — Part 4: Test conditions for isotropic and orthotropic fibre-reinforced plastic composites*

ISO 527-5, *Plastics — Determination of tensile properties — Part 5: Test conditions for unidirectional fibre-reinforced plastic composites*

ISO 2078, *Textile glass — Yarns — Designation*

ISO 2531, *Ductile iron pipes, fittings, accessories and their joints for water or gas applications*

ISO 3126, *Plastics piping systems — Plastics components — Determination of dimensions*

ISO 4200, *Plain end steel tubes, welded and seamless — General tables of dimensions and masses per unit length*

ISO 7432:2002, *Glass-reinforced thermosetting plastics (GRP) pipes and fittings — Test methods to prove the design of locked socket-and-spigot joints, including double-socket joints, with elastomeric seals*

ISO 7509, *Plastics piping systems — Glass-reinforced thermosetting plastics (GRP) pipes — Determination of time to failure under sustained internal pressure*

ISO 7511:1999, *Plastics piping systems — Glass-reinforced thermosetting plastics (GRP) pipes and fittings — Test methods to prove the leaktightness of the wall under short-term internal pressure*

ISO 7685, *Plastics piping systems — Glass-reinforced thermosetting plastics (GRP) pipes — Determination of initial specific ring stiffness*

ISO 8483:2003, *Glass-reinforced thermosetting plastics (GRP) pipes and fittings — Test methods to prove the design of bolted flange joints*

ISO 8513:2000, *Plastics piping systems — Glass-reinforced thermosetting plastics (GRP) pipes — Determination of longitudinal tensile properties*

ISO 8521:1998, *Plastics piping systems — Glass-reinforced thermosetting plastics (GRP) pipes — Determination of the apparent initial circumferential tensile strength*

ISO 8533:2003, *Glass-reinforced thermosetting plastics (GRP) pipes and fittings — Test methods to prove the design of cemented or wrapped joints*

ISO 8639:2000, *Glass-reinforced thermosetting plastics (GRP) pipes and fittings — Test methods for leaktightness of flexible joints*

ISO/TR 10465-3, *Underground installation of flexible glass-reinforced thermosetting resin (GRP) pipes — Part 3: Installation parameters and application limits*

ISO 10466, *Plastics piping systems — Glass-reinforced thermosetting plastics (GRP) pipes — Test method to prove the resistance to initial ring deflection*

ISO 10468, *Glass-reinforced thermosetting plastics (GRP) pipes — Determination of the long-term specific ring creep stiffness under wet conditions and calculation of the wet creep factor*

ISO 10471, *Glass-reinforced thermosetting plastics (GRP) pipes — Determination of the long-term ultimate bending strain and the long-term ultimate relative ring deflection under wet conditions*

ISO 10928:1997, *Plastics piping systems — Glass-reinforced thermosetting plastics (GRP) pipes and fittings — Methods for regression analysis and their use*

ISO 11922-1, *Thermoplastics pipes for the conveyance of fluids — Dimensions and tolerances — Part 1: Metric series*

ISO 14828, *Glass-reinforced thermosetting plastics (GRP) pipes — Determination of the long-term specific ring relaxation stiffness under wet conditions and calculation of the wet relaxation factor*

ISO 15306, *Glass-reinforced thermosetting plastics (GRP) pipes — Determination of the resistance to cyclic internal pressure*

EN 681-1, *Elastomeric seals — Materials requirements for pipe joint seals used in water and drainage applications — Part 1: Vulcanized rubber*

EN 681-2, *Elastomeric seals — Materials requirements for pipe joint seals used in water and drainage applications — Part 2: Thermoplastic elastomers*

JIS A 5350, *Fibreglass reinforced plastic mortar pipes*

3 Terms and definitions

For the purposes of this document, the following terms and definitions apply.

3.1

nominal size

DN

alphanumerical designation of size, which is common to all components in a piping system, which is a convenient round number for reference purposes and is related to the internal diameter in millimetres

NOTE The designation for reference or marking purposes consists of the letters DN plus a number.

3.2 declared diameter
 diameter which a manufacturer states to be the mean internal or external diameter produced in respect of a particular nominal size (DN)

3.3 nominal stiffness
SN
 alphanumeric designation of stiffness classification purposes, which has the same numerical value as the minimum initial value required, when expressed in newtons per square metre (N/m²) (see 4.1.5)

NOTE The designation for reference or marking purposes consists of the letters SN plus a number

3.4 specific ring stiffness
S
 measure of the resistance, in newtons per square metre, of a pipe to ring deflection per metre length under external load as defined by Equation (1):

$$S = \frac{E \times I}{d_m^3} \tag{1}$$

where

E is the apparent modulus of elasticity as determined in a ring stiffness test, in newtons per square metre (N/m²);

I is the second moment of area in the longitudinal direction per metre length, in metres to the fourth power per metre (m⁴/m), i.e.

$$I = \frac{e^3}{12} \tag{2}$$

e being the wall thickness, in metres (m);

d_m is the mean diameter of the pipe, in metres (m) (see 3.5)

3.5 mean diameter
d_m
 diameter of the circle corresponding to the middle of the pipe wall cross-section and given, in metres (m), by either Equation (3) or (4)

$$d_m = d_i + e \tag{3}$$

$$d_m = d_e - e \tag{4}$$

where

d_i is the internal diameter, in metres (m);

d_e is the external diameter, in metres (m);

e is the wall thickness of the pipe, in metres (m)

3.6**initial specific ring stiffness** S_0 value of S obtained when determined in accordance with ISO 7685, in newtons per square metre (N/m²)**3.7****wet creep factor** $\alpha_{x, \text{wet, creep}}$ ratio of the long-term specific ring stiffness, $S_{x, \text{wet}}$, at x years (see 4.6), determined under sustained loading in wet conditions in accordance with ISO 10468, to the initial specific ring stiffness, S_0 , both measured at the same position referred to as reference position 1

NOTE It is given by Equation (5):

$$\alpha_{x, \text{wet, creep}} = \frac{S_{x, 1, \text{wet}}}{S_{0, 1}} \quad (5)$$

3.8**wet relaxation factor** $\alpha_{x, \text{wet, relax}}$ ratio of the long-term specific ring stiffness, $S_{x, \text{wet}}$, at x years (see 4.6), determined under sustained deflection in wet conditions in accordance with ISO 14828, to the initial specific ring stiffness, S_0 , both measured at the same position, referred to as reference position 1

NOTE It is given by Equation (6):

$$\alpha_{x, \text{wet, relax}} = \frac{S_{x, 1, \text{wet}}}{S_{0, 1}} \quad (6)$$

3.9**calculated long-term specific ring stiffness** $S_{x, \text{wet}}$ calculated value of S (see 4.6) at x years, obtained by Equation (7):

$$S_{x, \text{wet}} = S_0 \times \alpha_{x, \text{wet}} \quad (7)$$

where

- x is the elapsed time, in years, specified in this International Standard (see 4.6);
- $\alpha_{x, \text{wet}}$ is either the wet creep factor (see 3.7) or the wet relaxation factor (see 3.8);
- S_0 is the initial specific ring stiffness, in newtons per square metre (N/m²) (see 3.6).

3.10**rating factor** R_{RF}

multiplication factor that quantifies the relation between a mechanical, physical or chemical property under the service conditions compared to the respective value at 23 °C and 50 % relative humidity (R.H.)

**3.11
nominal pressure
PN**

alphanumeric designation for pressure classification purposes which is numerically equal to the resistance of a component of a piping system to internal pressure, expressed in bars¹⁾

NOTE The designation for reference or marking purposes consists of the letters PN plus a number.

**3.12
type test**

test carried out in order to assess the fitness for purpose of a product or assembly of components to fulfil its or their function(s) in accordance with the product specification

**3.13
nominal length**

numerical designation of pipe length which is equal to the laying length (see 3.15), expressed in metres (m), rounded to the nearest whole number

**3.14
total length**

distance between two planes normal to the pipe axis and passing through the extreme end points of the pipe, expressed in metres (m)

**3.15
laying length**

total length of a pipe minus, where applicable, the manufacturer's recommended insertion depth of the spigot(s) in the socket

**3.16
normal service conditions**

conveyance of surface water or sewage in the temperature range 2 °C to 50 °C, with or without pressure, for 50 years

NOTE At temperatures above 35 °C, it may be necessary to rerate the pipe.

**3.17
working pressure**

P_w
internal pressure, excluding surge, at which a system is to be continuously operated, expressed in bars

**3.18
maximum working pressure**

maximum internal pressure, excluding surge, at which a system can be continuously operated, expressed in bars

**3.19
surge**

rapid change in internal pressure, either positive or negative, caused by a change in the flow velocity

NOTE It is expressed in bars.

**3.20
surge allowance**

value, expressed in bars or as a percentage of the maximum working pressure of a pipe, that can be added to the maximum working pressure to allow for occasional fluctuations in pressure

NOTE The value may vary depending upon the anticipated frequency of the surge conditions.

1) 1 bar = 10⁵ N/m² = 100 kPa (or = 0,1 MPa)

3.21**static design pressure**

maximum working pressure of a system, taking into account current and future use, fixed by the designer

NOTE It is expressed in bars.

3.22**maximum design pressure**

maximum working pressure, including surge, that the designer anticipates in a system

NOTE It is expressed in bars.

3.23**non-pressure pipe or fitting**

pipe or fitting subjected to an internal pressure not greater than 1 bar

3.24**pressure pipe or fitting**

pipe or fitting having a nominal pressure classification, expressed in bars, greater than 1 bar and which is intended to be used at internal pressures up to its nominal pressure in bars

3.25**buried pipeline**

pipeline which is subjected to the external pressure transmitted from soil loading, including traffic and superimposed loads and possibly the pressure of a head of water

3.26**non-buried pipeline**

pipeline which is subjected to negative and positive pressure, forces resulting from its supports, environmental conditions, e.g. snow and wind, and possibly the pressure of a head of water

3.27**sub-aqueous pipeline**

pipeline which is subjected to an external pressure arising from a head of water and conditions such as drag and lift caused by current and wave action

3.28**design service temperature**

maximum sustained temperature at which a system is expected to operate, expressed in degrees Celsius (°C)

3.29**variance**

measure of dispersion based on the mean square deviation from the arithmetic mean

3.30**standard deviation**

σ

positive square root of the variance

3.31**coefficient of variation**

V

ratio of the standard deviation to the absolute value of the arithmetic mean [see Equation (8)]:

$$V = \frac{\text{Standard deviation of the population}}{\text{Mean of the population}} \quad (8)$$

NOTE In this International Standard, it is expressed as a percentage.

3.32
acceptable quality level
AQL

quality level which, for the purposes of sampling inspection of a continuous series of lots, is the limit of a satisfactory process-average percent nonconforming

3.33
projected failure pressure at 6 min

p_6
 value at 6 min derived from the pressure regression line obtained from long-term pressure tests performed in accordance with ISO 7509 and analysed in accordance with ISO 10928

3.34
projected failure pressure at 50 years

p_{50}
 value at 50 years derived from the pressure regression line obtained from long-term pressure tests performed in accordance with ISO 7509 and analysed in accordance with ISO 10928

3.35
pressure regression ratio

$R_{R,p}$
 ratio of the projected failure pressure at 50 years, p_{50} , to the projected failure pressure at 6 min, p_6 , obtained from long-term pressure tests performed in accordance with ISO 7509 [see Equation (9)] and analysed in accordance with ISO 10928

$$R_{R,p} = \frac{p_{50}}{p_6} \tag{9}$$

3.36
initial failure pressure

p_0
 pressure at which failure occurs with specimens subjected to short-term tests performed in accordance with ISO 8521

3.37
minimum failure pressure at 50 years

$p_{50, 97,5\% \text{ LCL, min}}$
 failure pressure at 50 years which 97,5 % of products are required to exceed [see Equation (10)]:

$$p_{50, 97,5\% \text{ LCL, min}} = PN \times \eta_t, PN, 97,5\% \text{ LCL, min} \tag{10}$$

3.38
minimum failure pressure at 6 min

$p_{6, \text{min}}$
 failure pressure at 6 min which 97,5 % of products are required to exceed [see Equation (11)]:

$$p_{6, \text{min}} = \frac{p_{50, 97,5\% \text{ LCL, min}}}{R_{R,p}} \tag{11}$$

3.39
correction factor for initial failure pressure

C
 factor used to convert projected 6-min values, p_6 , to initial failure pressure values, p_0 [see Equation (12)]:

$$C = \frac{p_0^2}{p_6} \tag{12}$$

3.40 minimum initial failure pressure

$p_{0, \min}$
initial failure pressure, determined in accordance with ISO 8521, which 97,5 % of products are required to exceed [see Equation (13)]:

$$P_{0, \min} = P_{6, \min} \times C \quad (13)$$

3.41 minimum design pressure

$p_{0, d}$
design initial failure pressure to ensure 97,5 % of products will exceed $p_{0, \min}$ [see Equation (14)]:

$$p_{0, d} = p_{0, \min} \times \frac{1}{(1 - Y \times 0,01 \times 1,96)} \quad (14)$$

3.42 minimum mean failure pressure at 50 years

$p_{50, \text{mean}, \min}$
failure pressure at 50 years which 50 % of products are required to exceed [see Equation (15)]:

$$p_{50, \text{mean}, \min} = PN \times \eta_t, PN, \text{mean} \quad (15)$$

where PN is expressed in bars

3.43 AQL multiplier

MPL_{test}
multiplier, whose value is dependent upon the specified AQL (see 3.32), that is used with the coefficient of variation (see 3.31)

EXAMPLES If the AQL = 6,5 %, then $MPL_{\text{test}} = 1,51$. If the AQL = 2,5 %, then $MPL_{\text{test}} = 1,96$.

3.44 tensile safety factor

η_t
safety factor which is applied to the tensile strength of a product

3.45 tensile safety factor related to $p_{50, 97,5 \% \text{ LCL}, \min}$

$\eta_t, PN, 97,5 \%, \min$
safety factor which is applied to the nominal pressure (PN) to ensure that 97,5 % of products when installed in the ground can operate at a working pressure, p_w (see 3.17), equal to PN without failure for at least 50 years

NOTE For further information, see ISO/TR 10465-3.

3.46 relative ring deflection

y/d_m
ratio of the change in diameter of a pipe, y , in metres, to its mean diameter, d_m (see 3.5)

NOTE It is derived as a percentage from Equation (16):

$$\text{Relative ring deflection} = \frac{y}{d_m} \times 100 \quad (16)$$

3.47
projected initial relative ultimate ring deflection

y_2/d_m
 projected deflection value at 2 min derived from the ultimate deflection regression line obtained from long-term ultimate deflection tests performed in accordance with ISO 10471 and analysed in accordance with ISO 10928

NOTE It is expressed as a percentage by multiplying by 100.

3.48
minimum initial relative specific ring deflection before bore cracking occurs

$(y_2, \text{bore}/d_m)_{\text{min}}$
 initial relative deflection at 2 min which a test piece is required to pass without bore cracking when tested in accordance with ISO 10466

NOTE It is expressed as a percentage by multiplying by 100.

3.49
minimum initial relative specific ring deflection before structural failure occurs

$(y_2, \text{struct}/d_m)_{\text{min}}$
 initial relative deflection at 2 min which a test piece is required to pass without structural failure when tested in accordance with ISO 10466

NOTE It is expressed as a percentage by multiplying by 100.

3.50
extrapolated long-term relative ultimate ring deflection

$y_{u, \text{wet}, x}/d_m$
 deflection value at x years (see 4.6) derived from the ultimate deflection regression line obtained from long-term deflection tests performed under wet conditions in accordance with ISO 10471 and analysed in accordance with ISO 10928

NOTE It is expressed as a percentage by multiplying by 100.

3.51
minimum long-term relative ultimate ring deflection

$(y_{u, \text{wet}, x}/d_m)_{\text{min}}$
 required minimum extrapolated value at x years (see 4.6) derived from the ultimate deflection regression line obtained from long-term deflection tests performed under wet conditions in accordance with ISO 10471

NOTE It is expressed as a percentage by multiplying by 100.

3.52
ultimate deflection regression ratio

$R_{R, dv}$
 ratio of the extrapolated long-term relative ultimate ring deflection at x years (see 4.6), $y_{u, \text{wet}, x}/d_m$ (see 3.50), to the projected initial ultimate ring deflection, y_2/d_m (see 3.47), obtained from long-term ultimate ring deflection tests performed in accordance with ISO 10471 [see Equation (17)] and analysed in accordance with ISO 10928

$$R_{R, dv} = \frac{y_{u, \text{wet}, x}/d_m}{y_2/d_m} \tag{17}$$

3.53
angular deflection

δ
 angle between the axes of two consecutive pipes (see Figure 1), expressed in degrees (°)

3.54**draw***D*

longitudinal movement of a joint (see Figure 1), expressed in millimetres (mm)

3.55**total draw***T*

sum of the draw, *D*, and the additional longitudinal movement, *J*, of joint components due to the presence of angular deflection (see Figure 1), expressed in millimetres (mm)

3.56**misalignment***M*

amount by which the centrelines of consecutive components fail to coincide (see Figure 1), expressed in millimetres (mm)

3.57**flexible joint**

joint which allows relative movement between the components being joined

NOTE Flexible joints which have resistance to axial loading are classified as end-load-bearing.

Examples of this type of joint are:

- a) socket-and-spigot joints with an elastomeric sealing element (including double-socket designs);
- b) locked socket-and-spigot joints with an elastomeric sealing element (including double-socket designs);
- c) mechanically clamped joints, e.g. bolted couplings including components made of materials other than GRP.

3.58**rigid joint**

joint which does not allow relative movement between the components being joined

NOTE Rigid joints which do not have resistance to axial loading are classified as non-end-load-bearing.

Examples of this type of joint are:

- a) flanged joints including integral or loose flanges;
- b) wrapped or cemented joints.

3.59**break**

condition where the test piece can no longer carry the load to which it is being subjected

3.60**combined tensile safety factor** γ_{hat}

safety factor for combined circumferential tensile loading arising from internal pressure and flexure

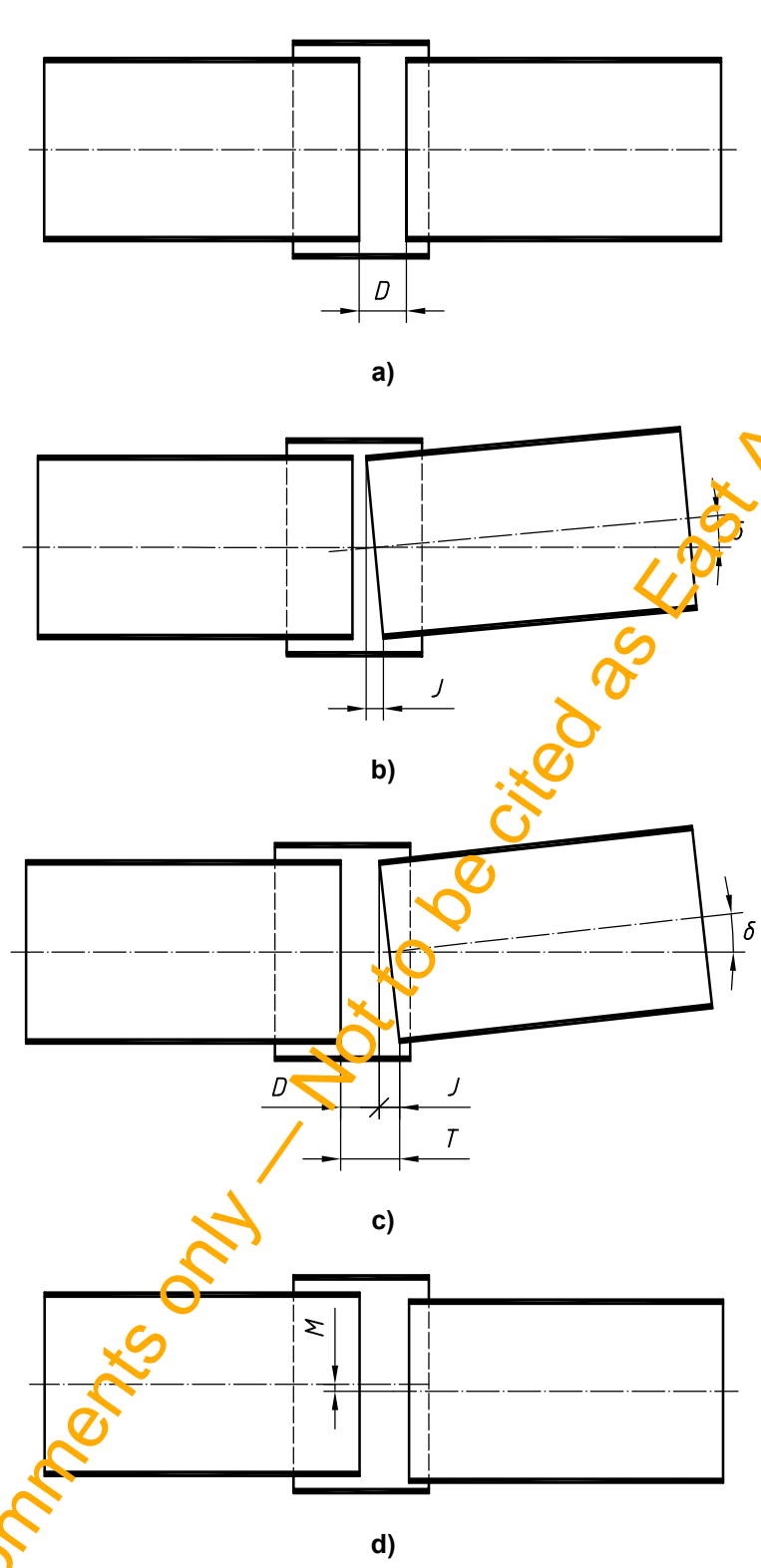

Key

- D draw
- J longitudinal movement arising from angular deflection of the joint
- δ angular deflection of the joint
- T total draw
- M misalignment

Figure 1 — Joint movements

4 General

4.1 Classification

4.1.1 Categories

Pipes and fittings shall be classified according to nominal size (DN) (see 3.1), nominal pressure (PN) (see 3.11) and joint type.

In addition, pipes shall include nominal stiffness (SN) (see 3.3) in their classification.

4.1.2 Nominal size

The nominal size (DN) of pipes and fittings in the range DN 50 to DN 4000 shall conform to the appropriate Tables in Clause 5 of this International Standard. If a thermoplastics liner is present, its internal diameter shall be declared by the manufacturer. The tolerance on the diameter shall be as specified in Clause 5 of this International Standard.

4.1.3 Nominal stiffness

The nominal stiffness (SN) shall conform to one of those given in Table 1 (see Notes 1 to 3 to Table 1).

Table 1 — Nominal stiffness (SN)

Nominal stiffness	
Series S1	Series S2
630	500
1250	1000
2500	2000
5000	4000
10000	8000

NOTE 1 Series S1 is the preferred series for GRP-UP pipes and series S2 is an alternative series.

NOTE 2 These nominal stiffnesses correspond to the values specified in Clause 5 of this International Standard for the minimum initial specific ring stiffness in newtons per square metre (N/m²).

NOTE 3 Pipes of nominal stiffness less than SN 1000 are not intended for laying directly in the ground.

Where special applications require the use of pipes having a higher nominal stiffness than those given in Table 1, the pipe shall be marked SN *X*, where *X* is the nominal stiffness of the pipe.

4.1.4 Nominal pressure

The nominal pressure (PN) shall conform to one of those given in Table 2.

Where pressures other than the nominal values in Table 2 are to be supplied by agreement between the manufacturer and the purchaser the pressure marking shall be PN *X*, where *X* is the value.

Table 2 — Nominal pressure (PN)

Nominal pressure
1
(2,5)
(4)
6
(9)
10
(12)
(15)
16
(18)
(20)
25
32
NOTE 1 Values in parentheses are non-preferred nominal pressures.
NOTE 2 Pipes marked PN 1 are non-pressure (gravity) pipes.

4.2 Materials

4.2.1 General

The pipe or fitting shall be constructed using chopped and/or continuous glass filaments, strands or rovings, mats or fabric, and polyester resin with or without fillers and, if applicable, with those additives necessary to impart specific properties to the resin. The pipe or fitting may also incorporate aggregates and, if required, a thermoplastics liner.

4.2.2 Reinforcement

The glass used for the manufacture of the reinforcement shall be of one of the following types:

- type E, comprising primarily either oxides of silicon, aluminium and calcium (alumino-calcosilicate glass) or silicon, aluminium and boron (alumino-borosilicate glass);
- type C, comprising primarily oxides of silicon, sodium, potassium, calcium and boron (alkali-metal calcium glass with an increased boron trioxide content) which is intended for applications requiring enhanced chemical resistance.

In either of these types of glass, small amounts of oxides of other metals will be present.

NOTE These descriptions for type C glass and type E glass are consistent with, but more specific than, those given in ISO 2078.

The reinforcement shall be made from continuously drawn filaments of type E or type C glass, and shall have a surface finish compatible with the resin to be used. It may be used in any form, e.g. as continuous or chopped filaments, strands or rovings, mat or fabric. Surface mats or veils of synthetic (organic) fibres may be used on the surfaces of the components.

4.2.3 Resin

The resin used in the structural layer (see 4.3.2) shall have a temperature of deflection of at least 70 °C when tested in accordance with method A of ISO 75-2:2004 with the test specimen in the edgewise position.

4.2.4 Aggregates and fillers

The particle size of aggregates and fillers shall not exceed 1/5 of the total wall thickness of the pipe or fitting or 2,5 mm, whichever is the smaller.

4.2.5 Thermoplastics liners

When using a thermoplastics liner that requires a bonding material, care shall be taken to ensure that the bonding material is compatible with all other materials used in the pipe construction.

4.2.6 Elastomers

The elastomeric material(s) of the seal shall conform to the applicable part of EN 681 or, if available, a similar national standard that is acceptable to both the purchaser and supplier.

4.2.7 Metals

Metallic components may be used in the system.

4.3 Wall construction

4.3.1 Inner layer

The inner layer shall comprise one of the following:

- a) a thermosetting resin layer with or without aggregates and fillers and with or without a reinforcement;
- b) a thermoplastics liner.

The resin used in this inner layer need not conform to the temperature of deflection requirements given in 4.2.3.

4.3.2 Structural layer

The structural layer shall consist of glass reinforcement and a thermosetting resin, with or without aggregates or fillers.

4.3.3 Outer layer

The construction of the outer layer of the pipe shall take into account the environment in which the pipe is to be used. This layer shall be formed of a thermosetting resin with or without aggregates and fillers and with or without a reinforcement made of glass or synthetic filaments.

NOTE Special constructions may be necessary where the pipe is exposed to extreme climatic, environmental or ground conditions. For example, provision may be made for the inclusion of pigments or inhibitors for extreme climatic conditions or to give fire-retarding properties.

The resin used in this outer layer need not conform to the temperature of deflection requirements in 4.2.3.

4.4 Appearance

Both the internal and the external surfaces shall be free from irregularities which would impair the ability of the component to conform to the requirements of this International Standard.

4.5 Reference conditions for testing

4.5.1 Temperature

The mechanical, physical and chemical properties specified in this International Standard shall, unless otherwise specified, be determined at $(23 \pm 5) ^\circ\text{C}$.

For service temperatures over $35 ^\circ\text{C}$, type tests shall be carried out at least at the design service temperature (see 3.28) to establish derating factors for all long-term properties of relevance to the design of pipes and fittings.

4.5.2 Properties of water for testing

The water used for the tests referred to in this International Standard shall be tap water having a pH of 7 ± 2 .

4.5.3 Loading conditions

Unless otherwise specified, the mechanical, physical and chemical properties specified in this International Standard shall be determined using circumferential and/or longitudinal loading conditions, as applicable.

4.5.4 Conditioning

Unless otherwise specified, in cases of dispute store the test piece(s) in air at the test temperature specified in 4.5.1 for at least 24 h prior to testing.

4.5.5 Measurement of dimensions

In cases of dispute, determine the dimensions of GRP components at the temperature specified in 4.5.1. Make all measurements in accordance with ISO 3126 or using any other method of sufficient accuracy to determine conformity or non-conformity with the applicable limits. Make all routine measurements at the prevailing temperature or, if the manufacturer prefers, at the temperature specified in 4.5.1.

4.6 Elapsed time, x , for determination of long-term properties

The subscript x in, for example, $S_{x, \text{wet}}$ (see 3.8) denotes the time at which the long-term property is to be determined. Unless otherwise specified, the long-term properties shall be determined at 50 years (438 000 h).

4.7 Joints

4.7.1 General

If requested, the manufacturer shall declare the length and the maximum external diameter of the assembled joint.

4.7.2 Types of joint

A joint shall be classified as either flexible (see 3.57) or rigid (see 3.58), and in either case the manufacturer shall declare whether or not it is capable of resisting end loads.

4.7.3 Flexibility of the joint

4.7.3.1 Allowable angular deflection

The manufacturer shall declare the allowable angular deflection (see 3.53) for which each joint is designed.

Flexible joints, i.e. those which are not locked, shall have a maximum allowable angular deflection that is not less than the applicable value given below:

- 3° for pipes and/or fittings with a nominal size equal to or less than DN 500;
- 2° for pipes and/or fittings with a nominal size greater than DN 500 but equal to or less than DN 900;
- 1° for pipes and/or fittings with a nominal size greater than DN 900 but equal to or less than DN 1800;
- 0,5° for pipes and/or fittings with a nominal size greater than DN 1800.

For locked joints, the manufacturer shall declare the maximum allowable angular deflection.

By agreement between the manufacturer and the purchaser, flexible joints intended to be used at pressures greater than 16 bar may have lower allowable angular deflections than those given in this subclause.

4.7.3.2 Allowable draw

The manufacturer shall declare the maximum allowable draw (see 3.54) for which each joint is designed.

For flexible joints, the maximum allowable draw, which includes Poisson contraction and temperature effects, shall not be less than 0,3 % of the laying length of the longest pipe which it is intended to use in the case of pressure pipes and 0,2 % in the case of non-pressure pipes. For locked joints, the manufacturer shall declare the maximum allowable draw.

4.7.4 Sealing ring

The sealing ring shall not have any detrimental effect on the properties of the components with which it is used and shall not cause the test assembly to fail the performance requirements specified in Clause 7 of this International Standard.

4.7.5 Adhesives

Adhesives, if required for jointing, shall be as specified by the manufacturer of the joint. The joint manufacturer shall ensure that the adhesives do not have any detrimental effects on the components with which they are used and shall not cause the test assembly to fail the performance requirements specified in Clause 7 of this International Standard.

4.8 Effect on water quality

Attention is drawn to the need for components to comply with any national regulations on the quality of drinking water in force at the location where the components are to be used.

5 Pipes

5.1 Geometrical characteristics

5.1.1 Diameter

5.1.1.1 Diameter series

NOTE In standardizing the diameters of GRP pipes, difficulties are encountered because of the various methods used to manufacture them (e.g. filament winding, centrifugal casting or contact moulding). Typically GRP pipes are produced by controlling either the internal diameter or the external diameter to a fixed value.

Unless otherwise agreed between the manufacturer and the purchaser, GRP pipes shall be designated by nominal size in accordance with one of the following two series:

- **series A**, which specifies the internal diameter as being equal to the nominal size in millimetres;
- **series B**, which specifies the external diameter in millimetres.

5.1.1.2 Nominal size

Unless otherwise agreed between the manufacturer and the purchaser, the nominal size (DN) shall be chosen from the values given in Table 3.

Table 3 — Nominal size (DN)

Nominal size			
50	600	(1650)	(2900)
75	700	(1700)	3000
100	(750)	1800	(3100)
125	800	(1900)	3200
150	900	2000	(3300)
200	1000	(2100)	3400
250	(1100)	2200	(3500)
300	1200	(2300)	3600
350	(1300)	2400	(3700)
(375)	(1350)	(2500)	3800
400	1400	2600	(3900)
450	(1500)	(2700)	4000
500	1600	2800	
NOTE Figures in parentheses are non-preferred values.			

5.1.1.3 Specified diameters

5.1.1.3.1 General

Pipes may be supplied conforming to 5.1.1.3.2 (series A), 5.1.1.3.3 (series B) or, by agreement between the manufacturer and the purchaser, another diameter series.

Pipes having other diameters may be supplied by agreement between the manufacturer and the purchaser.

5.1.1.3.2 Series A (internal diameter specified)

The internal diameter, in millimetres, shall conform to the applicable values relative to the nominal size given in Table 4.

5.1.1.3.3 Series B (external diameter specified)

The external diameter, in millimetres, shall conform to the applicable value relative to the nominal size given in Table 5, Table 6 or Table 7.

The dimensions of pipes with nominal sizes between DN 300 and DN 4000 to be used with GRP fittings conforming to Clause 6 of this International Standard shall conform to those given for series B1.

The dimensions of pipes with nominal sizes between DN 100 and DN 600 to be used with either GRP fittings conforming to Clause 6 of this International Standard or with ductile-iron fittings conforming to ISO 2531 shall conform to those given for series B2.

NOTE When specifying the use of ductile-iron fittings with GRP pipes, care should be taken to ensure their dimensional compatibility with the GRP pipe.

The dimensions of pipes with nominal sizes between DN 100 and DN 600 to be used with either GRP fittings conforming to Clause 6 of this International Standard or with PVC fittings conforming to ISO 161-1 and the tolerances to ISO 11922-1 shall conform to those given for series B3.

The dimensions of pipes with nominal sizes between DN 100 and DN 300 to be used with either GRP fittings conforming to Clause 6 of this International Standard or steel pipes conforming to ISO 4200 shall conform to those given for series B4.

The dimensions of pipes with nominal sizes between DN 50 and DN 800 to be used with either GRP fittings conforming to Clause 6 of this International Standard or with metallic pipes conforming to standards not covered by series B2 or B4 shall conform to those given for series B5.

The dimensions of pipes with nominal sizes between DN 200 and DN 2400 to be used with either GRP fittings conforming to Clause 6 of this International Standard or with GRP pipes conforming to Japanese standard JIS A 5350 shall conform to those given for series B6.

5.1.1.3.4 Minimum internal diameters for pipes with a prefabricated thermoplastics liner

The internal diameter of the thermoplastics liner shall not be less than 96,5 % of the nominal size of the pipe.

5.1.1.4 Tolerances

NOTE Where interchangeability is required, see Clause 7 of this International Standard for further information.

5.1.1.4.1 Series A — Tolerances on internal diameter

The declared internal diameter of a pipe shall be between the minimum and maximum values given in columns 2 and 3 of Table 4. The average internal diameter at any point along the length of the pipe shall not deviate from the declared internal diameter by more than the permissible deviation given in column 4 of Table 4.

For GRP pipes which have a liner made from thermoplastics pipes, the tolerances on the internal diameter shall be as specified in the relevant thermoplastics pipe standard. The internal diameter of GRP pipes which have a liner fabricated from thermoplastics sheet shall conform to the applicable value in Table 4 and its tolerances.

Table 4 — Series A — Specified pipe internal diameters and tolerances

Dimensions in millimetres

Column 1	Column 2	Column 3	Column 4
Nominal size (DN)	Range of declared pipe internal diameters		Permissible deviation from declared internal diameter
	min.	max.	
100	97	103	± 1,5
110	107	113	± 1,5
125	122	128	± 1,5
150	147	153	± 1,5
200	196	204	± 1,5
225	221	229	± 1,5
250	246	255	± 1,5
300	296	306	± 1,8
350	346	357	± 2,1
400	396	408	± 2,4
450	446	459	± 2,7
500	496	510	± 3,0
600	595	612	± 3,6
700	695	714	± 4,2
800	795	816	± 4,2
900	895	918	± 4,2
1000	1 195	1 220	± 5,0
1200	1 395	1 420	± 5,0
1400	1 595	1 620	± 5,0
1600	1 795	1 820	± 5,0
1800	1 995	2 020	± 5,0
2000	2 195	2 220	± 5,0
2200	2 395	2 420	± 5,0
2400	2 595	2 620	± 6,0
2600	2 795	2 820	± 6,0
2800	2 995	3 020	± 6,0
3000	3 195	3 220	± 6,0
3200	3 395	3 420	± 6,0
3400	3 595	3 620	± 6,0
3600	3 795	3 820	± 6,0
3800	3 995	4 020	± 7,0
4000	1 195	1 220	± 7,0

NOTE 1 When a non-preferred size is selected from Table 3, the range of diameters and the permissible deviations shall be interpolated between the preferred sizes immediately above and below the non-preferred size.

NOTE 2 When a manufacturer supplies pipes with a definable change in diameter from one end to the other, then the manufacturer may declare the diameters at each end and it is these declared values which will be subject to the tolerances given in column 4.

5.1.1.4.2 Series B1 — Tolerances on external diameter

The external diameter of a pipe at the spigot shall be as given in Table 5. The manufacturer shall declare the actual maximum and minimum external diameters of the pipe at the spigot.

Table 5 — Series B1 — Specified pipe external diameters and tolerances

Dimensions in millimetres

Nominal size (DN)	External diameter of pipe	Permissible deviation	
		Upper limit	Lower limit
300	310	+1,0	-1,0
350	361		-1,2
400	412		-1,4
450	463		-1,6
500	514		-1,8
600	616		-2,0
700	718		-2,2
800	820		-2,4
900	924		-2,6
1000	1 026		+2,0
1200	1 229	-2,6	
1400	1 434	-2,8	
1600	1 638	-2,8	
1800	1 842	-3,0	
2000	2 046	+2,0	-3,0
2200	2 250		-3,2
2400	2 453		-3,4
2600	2 658		-3,6
2800	2 861		-3,8
3000	3 066		-4,0
3200	3 270		-4,2
3400	3 474		-4,4
3600	3 678		-4,6
3800	3 882		-4,8
4000	4 086	-5,0	

NOTE When a non-preferred size is selected from Table 3, the range of diameters and the permissible deviations shall be interpolated between the preferred sizes immediately above and below the non-preferred size.

5.1.1.4.3 Series B2, B3 and B4 — Tolerances on external diameter

The tolerances on the external diameter, at the spigot, for series B2, B3 and B4 pipes shall be as given in Table 6.

Table 6 — Series B2, B3 and B4 — Specified pipe external diameters and tolerances

Dimensions in millimetres

Nominal size (DN)	Series B2			Series B3			Series B4		
	External diameter	Permissible deviation		External diameter	Permissible deviation		External diameter	Permissible deviation	
		Upper limit	Lower limit		Upper limit	Lower limit		Upper limit	Lower limit
100	115,0	+1,5	+0,3	110	+0,4	+1,5	114,3	+1,5	-0,2
125	141,0		+0,2	125	+0,4		129,7		
150	167,0		+0,1	160	+0,5		168,3		
200	220,0		0,0	200	+0,6		219,1		
225	—		—	225	+0,7		—		
250	271,8		-0,2	250	+0,8		273,0		
300	323,8		-0,3	315	+1,0		323,9		
350	375,7		-0,3	355	+1,1		—		
400	426,6		-0,3	400	+1,2		—		
450	477,6		-0,4	450	+1,4		—		
500	529,5		-0,4	500	+1,5		—		
600	632,5		-0,5	630	+1,9		—		

NOTE When a non-preferred size is selected from Table 5, use the nearest relevant size from the appropriate standard.

5.1.1.4.4 Series B5 — Tolerances on external diameter

The declared external diameter for series B5 shall be between the values given in Table 7 for the applicable nominal size and be subject to the tolerances for the metallic pipes with which they are to be used.

The tolerances applicable to these dimensions depend on the joint. Upon request by the purchaser, the manufacturer shall provide detailed toleranced dimensions of the pipes used for particular joints.

Table 7 — Series B5 — Specified external diameters

Dimensions in millimetres

Column 1	Column 2	Column 3
Nominal size (DN)	Range of declared pipe external diameters	
	min.	max.
50	63	64
75	100	101
100	121	122
150	175	177
200	229	232
250	281	286
300	335	345
350	388	399
400	426	453
450	495	507
500	548	587
700	655	747
800	812	826

5.1.1.4.5 Series B6 — Tolerances on external diameter

The external diameter of a pipe at the spigot shall be as given in Table 8. The manufacturer shall declare the actual maximum and minimum external diameter of a pipe at the spigot.

Table 8 — Series B6 — Specified pipe external diameters and tolerances

Dimensions in millimetres

Nominal size (DN)	External pipe diameter	Permissible deviation		Nominal size (DN)	External pipe diameter	Permissible deviation	
		Upper limit	Lower limit			Upper limit	Lower limit
200	220	+1,5	-0,5	1000	1 050	+2,0	-1,0
250	271			1100	1 156		
300	322			1200	1 262		
350	373			1350	1 418		
400	424			1500	1 574		
450	475			1650	1 732		
500	526	+2,0	-1,0	1800	1 890	+2,5	-1,5
600	631			2000	2 098		
700	736			2200	2 308		
800	840			2400	2 518		
900	944						

5.1.2 Wall thickness

If requested, the manufacturer shall declare the minimum total wall thickness, including the liner. It shall not be less than 3 mm.

5.1.3 Length

5.1.3.1 Nominal length

Unless otherwise agreed between the manufacturer and the purchaser, the nominal length (see 3.13) shall be one of the following values:

- 3, 4, 5, 6, 9, 10, 12 or 18.

5.1.3.2 Laying length

Pipes shall be supplied in laying lengths (see 3.15) in accordance with the requirements given in the following paragraph. The tolerance on the laying length shall be ± 60 mm.

Of the total quantity of pipes supplied of each diameter, the manufacturer may supply up to 10 % in lengths shorter than the nominal length unless a higher percentage of such pipes has been agreed between the manufacturer and the purchaser. In all cases where the effective length of the pipe is not within 60 mm of the nominal length, the actual laying length of the pipe shall be marked on the pipe.

5.2 Mechanical characteristics

5.2.1 Initial specific ring stiffness

5.2.1.1 General

The initial specific ring stiffness, S_0 (see 3.6), shall be determined using either of the methods given in ISO 7685. The test pieces shall conform to 5.2.1.2 and 5.2.1.3. Conduct the test using a relative ring deflection (see 3.46) between 2,5 % and 3,5 %. Where the nominal stiffness exceeds SN 10000, perform the test using a relative deflection calculated using Equation (18):

$$\text{Relative deflection (\%)} = \frac{65}{\sqrt[3]{SN}} \pm 0,5 \quad (18)$$

The value determined for the initial specific ring stiffness, S_0 , shall not be less than the applicable value of $S_{0, \min}$ given in Table 9. For nominal stiffnesses greater than SN 10000, the initial stiffness, in N/m², shall not be less than the numerical value of the nominal stiffness.

Table 9 — Minimum initial specific ring stiffness values

Nominal stiffness (SN) ^a	$S_{0, \min}$ ^b N/m ²
500	500
630	630
1000	1 000
1250	1 250
2000	2 000
2500	2 500
4000	4 000
5000	5 000
8000	8 000
10000	10 000

^a See Notes 1 to 3 to Table 1.

^b For other stiffnesses, the value of $S_{0, \min}$ shall be equal to SN X (see 4.1.3).

5.2.1.2 Number of test pieces for type testing

Two test pieces, of the same size and classification and conforming to 5.2.1.3, shall be used.

5.2.1.3 Length of test pieces

The length, L_p , of the test piece shall be 0,3 m \pm 5 % for all nominal sizes.

5.2.2 Long-term specific ring stiffness

5.2.2.1 Temperature of the water

The temperature of the water shall be (23 ± 5) °C (see 4.5).

5.2.2.2 Method of test to determine S_0

Before performing the test detailed in 5.2.2.5, determine the initial specific ring stiffness, S_0 , of the test pieces in accordance with 5.2.1 using test pieces conforming to 5.2.2.7.

5.2.2.3 Time intervals for measurement

Commencing 1 h after completion of loading and continuing for more than 10 000 h, measure to within 2 % of the initial value and record the deflection readings. The intervals between readings shall be such that ten readings are taken at approximately equally spaced intervals of log-time for each decade of log-time in hours.

5.2.2.4 Elapsed time at which the property is to be determined

The elapsed time at which this property is to be determined is 50 years in accordance with 4.6 of this International Standard.

5.2.2.5 Method of test

5.2.2.5.1 General

Perform the test using one of the methods described in 5.2.2.5.2 and 5.2.2.5.3.

5.2.2.5.2 Using relaxation

Determine the long-term specific ring relaxation stiffness, $S_{x, \text{wet, relax}}$, and the relaxation factor, $\alpha_{x, \text{wet, relax}}$, from data derived from the test performed in accordance with ISO 14828 using an initial strain of between 0,35 % and 0,4 %.

5.2.2.5.3 Using creep

Determine the long-term specific ring creep stiffness, $S_{x, \text{wet, creep}}$, and the creep factor, $\alpha_{x, \text{wet, creep}}$, from data derived from the test performed in accordance with ISO 10468 using an initial strain of between 0,13 % and 0,17 %.

5.2.2.6 Requirement

When test pieces conforming to 5.2.2.7 are tested in accordance with the applicable method given in 5.2.2.5, the relaxation factor, $\alpha_{x, \text{wet, relax}}$, or the creep factor, $\alpha_{x, \text{wet, creep}}$, shall be as declared by the manufacturer.

5.2.2.7 Number of test pieces for type testing

Use two test pieces of the same size and classification and of length, L_p , conforming to 5.2.1.3.

5.2.2.8 Determination of minimum long-term specific ring stiffness

The manufacturer shall determine for the pipes he produces either the minimum long-term specific creep stiffness, $S_{x, \text{wet, creep, min}}$, or the minimum long-term specific relaxation stiffness, $S_{x, \text{wet, relax, min}}$, using Equation (19) or (20), as applicable:

$$S_{x, \text{wet, creep, min}} = S_{0, \text{min}} \times \alpha_{x, \text{wet, creep}} \quad (19)$$

$$S_{x, \text{wet, relax, min}} = S_{0, \text{min}} \times \alpha_{x, \text{wet, relax}} \quad (20)$$

where $S_{0, \text{min}}$ is the applicable minimum initial specific ring stiffness value given in Table 9.

The value(s) determined shall be as declared by the manufacturer.

5.2.3 Initial resistance to failure in a deflected condition

5.2.3.1 General

Determine the initial resistance to failure in a deflected condition using the method given in ISO 10466. The test pieces shall conform to 5.2.3.4. Conduct the test using mean diametrical deflections appropriate to the nominal stiffness (SN) of the pipe as specified in 5.2.3.3.1 for item a) of 5.2.3.2 and as determined in accordance with 5.2.3.3.2 for item b) of 5.2.3.2.

5.2.3.2 Requirement

When tested in accordance with the method given in ISO 10466, each test piece shall conform to the following requirements:

- a) when inspected without magnification, the test piece shall be free from bore cracks (see 5.2.3.3.1);
- b) the test piece shall not show structural failure in any of the following forms (see 5.2.3.3.2):
 - 1) interlaminar separation,
 - 2) tensile failure of the glass fibre reinforcement,
 - 3) buckling of the pipe wall,
 - 4) if applicable, separation of the thermoplastics liner from the structural wall.

5.2.3.3 Minimum initial relative specific ring deflection

5.2.3.3.1 For bore cracks

The minimum initial relative specific ring deflection before bore cracking occurs (see 3.48) is given in Table 10 for the appropriate nominal stiffness of the test piece. For nominal stiffnesses greater than SN 10000, calculate the minimum initial relative specific ring deflection before bore cracking, $y_{2, \text{bore}}/d_m$, in percent, using Equation (21):

$$\left(y_{2, \text{bore}}/d_m \right)_{\text{new, min}} \times 100 = \frac{194}{\sqrt[3]{\text{SN}}} \quad (21)$$

where

$\left(y_{2, \text{bore}}/d_m \right)_{\text{new, min}} \times 100$ is the required minimum 2 min initial relative specific ring deflection calculated, in percent, for the nominal stiffness of the test piece;

SN

is the nominal stiffness of the test piece.

For individual test pieces having a nominal stiffness greater than SN 10000, calculate the minimum initial relative specific ring deflection before bore cracking, $y_{2, \text{bore}}/d_m$, in percent, using Equation (21), but using the measured initial specific ring stiffness of the test piece instead of its nominal stiffness.

Table 10 — Minimum 2 min initial relative specific ring deflection before bore cracking $(y_{2, \text{bore}}/d_m)_{\text{min}}$

Nominal stiffness (SN)	500	630	1000	1250	2000	2500	4000	5000	8000	10000
No sign of bore cracking at a percentage relative specific ring deflection of:	24,4	22,7	19,4	18	15,4	14,3	12,2	11,3	9,7	9

5.2.3.3.2 For structural failure

The minimum initial relative specific ring deflection before structural failure (see 3.4.9) is given in Table 11 for the appropriate nominal stiffness of the test piece. For nominal stiffnesses greater than SN 10000, calculate the minimum initial ring deflection before structural failure, $y_{2, \text{struct}}/d_m$, in percent, using Equation (22):

$$(y_{2, \text{struct}}/d_m)_{\text{new, min}} \times 100 = \frac{324}{\sqrt[3]{\text{SN}}} \tag{22}$$

where

$(y_{2, \text{struct}}/d_m)_{\text{new, min}} \times 100$ is the required minimum 2 min initial relative specific ring deflection calculated, in percent, for the nominal stiffness of the test piece;

SN is the nominal stiffness of the test piece.

For individual test pieces having a nominal stiffness greater than SN 10000, calculate the minimum initial relative specific ring deflection before structural failure, $y_{2, \text{struct}}/d_m$, in percent, using Equation (22), but using the measured initial specific ring stiffness of the test piece instead of its nominal stiffness:

Table 11 — Minimum initial relative specific deflection before structural failure $(y_{2, \text{struct}}/d_m)_{\text{min}}$

Nominal stiffness (SN)	500	630	1000	1250	2000	2500	4000	5000	8000	10000
No sign of structural failure at a percentage relative specific ring deflection of:	40,8	37,8	32,4	30,0	25,7	23,9	20,4	18,9	16,2	15

5.2.3.4 Number of test pieces for type testing

Use three test pieces of the same size and classification and of length, L_p , conforming to 5.2.1.3.

5.2.4 Ultimate long-term resistance to failure in a deflected condition

5.2.4.1 General

Determine the ultimate long-term resistance to failure in a deflected condition using the method given in ISO 10471, using at least 18 test pieces conforming to 5.2.4.5.

5.2.4.2 Requirement

Calculate, in accordance with method A of ISO 10928:1997, the initial ultimate ring deflection in percent at which structural failure occurs at 2 min, $y_{2, \text{struct}}/d_m$, the extrapolated x -year value (see 4.6) for the long-term ultimate ring deflection under wet conditions, $y_{u, \text{wet}, x}/d_m$, and the deflection regression ratio, R_{reg} .

When determined in accordance with the method given in ISO 10471, using a minimum of 18 test pieces conforming to 5.2.4.5, the extrapolated x -year value for the long-term relative ultimate ring deflection under wet conditions, $y_{u, \text{wet}, x}/d_m$, calculated in accordance with method A of ISO 10928:1997, shall not be less than the applicable value given in Table 12.

Table 12 — Minimum long-term relative ultimate ring deflection under wet conditions, $(y_{u, \text{wet}, x}/d_m)_{\text{min}}$

Nominal stiffness (SN)	500	630	1000	1250	2000	2500	4000	5000	8000	10000
Minimum extrapolated long-term relative ultimate ring deflection, %	24,4	22,7	19,4	18	15,4	14,3	12,2	11,3	9,7	9

NOTE 1 The deflection values given in this table are based on the assumption that the maximum allowable long-term deflection of a pipe buried in the ground is 6 %. For nominal stiffnesses greater than SN 10000, the maximum allowable long-term deflection of a pipe buried in the ground shall not exceed 67 % of the calculated minimum extrapolated long-term ring deflection (see Note 3).

The pipe manufacturer may, however, specify a long-term deflection different from the assumed value of 6 %. In such cases, the requirements in this table should be adjusted proportionately. For instance, if the manufacturer's value was 3 %, then the required values would be 50 % of those in this table, while a manufacturer's deflection value of 8 % would result in required values of 133 % of those in this table. For nominal stiffnesses greater than SN 10000, the same procedure shall be followed except that the calculated maximum long-term deflection shall be used instead of 6 %.

NOTE 2 The ultimate ring deflection values given in this table induce the same flexural strain in all the stiffness classes. Therefore the long-term ultimate ring deflection determined for one stiffness can be converted into a strain and this in turn can be converted into an ultimate ring deflection for any other stiffness class.

NOTE 3 For nominal stiffnesses greater than SN 10000 calculate the minimum long-term relative ultimate ring deflection using Equation (21).

5.2.4.3 Criteria for failure

The criteria for failure shall be as given in ISO 10471.

5.2.4.4 Distribution of failure times

The times to failure, t_u , of the 18 or more test pieces shall be distributed between 0,3 h and over 10^4 h and the distribution of ten of these results shall conform to the limits given in Table 13.

Table 13 — Failure time distribution

Failure time, t_u h	Minimum number of failure values
$10 \leq t_u \leq 1\ 000$	4
$1\ 000 < t_u \leq 6\ 000$	3
$6\ 000 < t_u$	3 ^a
^a At least one of these shall exceed 10 000 h.	

5.2.4.5 Test pieces for type testing

The test pieces required by the test detailed in 5.2.4 shall be cut from pipes having the same nominal size, nominal stiffness and nominal pressure class and shall have a length, L_p , conforming to 5.2.1.3.

5.2.5 Initial specific longitudinal tensile strength

5.2.5.1 General

Determine the initial specific longitudinal tensile strength in accordance with method A or method B of ISO 8513:2000 using test pieces conforming to 5.2.5.3.

5.2.5.2 Requirement

For pipes not required to resist the longitudinal load produced by the internal pressure acting under the relevant end-load conditions, when tested in accordance with method A or method B of ISO 8513:2000, using test pieces conforming to 5.2.5.3:

- a) for each pipe, the average value of the initial specific longitudinal tensile strength, σ_1^* , of the test pieces shall not be less than the value, given in Table 14, applicable to the nominal size (DN) of the pipe under test;
- b) for each pipe, the average value of the elongation to break (see 3.59) of the test pieces shall not be less than 0,25 %.

For pipes required to resist the longitudinal load produced by the internal pressure acting under the relevant end-load conditions, the minimum initial longitudinal specific tensile strength, σ_1^* , expressed in newtons per millimetre circumference, shall not be less than the value determined from Equation (23):

$$\sigma_1^* = 25 \times p_{0,d} \times d_m \quad (23)$$

where

$p_{0,d}$ is the initial design pressure (in bars) determined in accordance with 5.2.6.1;

d_m is the mean diameter of the pipe tested, in metres (m).

5.2.5.3 Number of test pieces for type testing

When testing in accordance with method A of ISO 8513:2000, cut five test pieces from each of three different pipes of the same nominal size, nominal stiffness and nominal pressure class.

When testing in accordance with method B of ISO 8513:2000, cut one test piece from each of three different pipes of the same nominal size, nominal stiffness and nominal pressure class.

When pipes having a nominal pressure or size different from those given in Table 14 are tested, obtain the required minimum initial specific longitudinal tensile strength by linear interpolation or extrapolation from the values given for the relevant nominal size.

Table 14 — Minimum initial specific longitudinal tensile strength

Nominal size (DN)	Nominal pressure (PN)					
	≤ 4	6	10	16	25	32
	Minimum initial specific longitudinal tensile strength					
N/mm of circumference						
50	50	55	60	70	90	105
75	60	65	70	80	100	115
100	70	75	80	90	110	125
125	75	80	90	100	120	135
150	80	85	100	110	130	145
200	85	95	110	120	140	155
250	90	105	125	135	165	190
300	95	115	140	150	190	220
400	105	130	160	185	240	285
500	115	150	190	220	290	345
600	125	165	220	255	345	415
700	135	180	250	290	395	475
800	150	200	280	325	450	545
900	165	215	310	355	505	620
1000	185	230	340	390	555	685
1200	205	260	380	460		
1400	225	290	420	530		
1600	250	320	460	600		
1800	275	350	500	670		
2000	300	380	540	740		
2200	325	410	580	810		
2400	350	440	620	880		
2600	375	470	660			
2800	400	505	705			
3000	430	540	750			
3200	460	575	795			
3400	490	610	840			
3600	520	645	885			
3800	550	680	930			
4000	580	715	975			

5.2.6 Initial design and failure pressures for pressure pipes

5.2.6.1 General

For pressure pipes (see 3.24), determine the initial failure pressure by one of methods A to F of ISO 8521:1998, using test pieces conforming to 5.2.6.4.

NOTE Method A of ISO 8521:1998 is considered as the reference method. However, all the methods in ISO 8521:1998 have equal validity. If correlation of any of methods B to F with method A can be established by a comparative test programme, then that method may be accepted as the reference method.

5.2.6.2 Requirement

When determined by one of methods A to F of ISO 8521:1998, using test pieces in accordance with 5.2.6.4, the value of the initial failure pressure, p_0 , calculated in accordance with this subclause, shall conform to the value derived using the procedure given in ISO 10928 for verification using destructive test data.

Using the pressure regression ratio, $R_{R,p}$, obtained from long-term pressure testing conducted in accordance with ISO 7509 and analysed by the procedures detailed in ISO 10928, determine the minimum initial failure pressure, $p_{0,min}$, and the minimum design pressure, $p_{0,d}$, both expressed in bars.

NOTE These procedures are described in Annex A.

All the methods described in ISO 8521:1998 result in a circumferential tensile wall strength. To compare these results with the requirements given in 5.2.6.2.1, convert the specific circumferential tensile wall strength into a pressure value by the following equation:

$$p_0 = 0,02 \times \sigma_{cu} / d_m$$

where

σ_{cu} is the circumferential tensile wall strength, determined in accordance with ISO 8521:1998, in newtons per millimetre length;

d_m is the mean diameter of the pipe tested, in metres;

p_0 is the initial failure pressure, in bars.

5.2.6.3 $p_{0,mean}$

The value of $p_{0,mean}$, in bars, which is the average of the last 20 initial failure pressure test results, shall be equal to or greater than the value of the minimum design pressure, $p_{0,d}$, determined from Equation (24):

$$p_{0,mean} \geq p_{0,d} = C \times \frac{PN}{R_{R,p}} \times \eta_t, PN, 97,5\% \text{ LCL} \times \frac{1}{(1 - Y \times 0,01 \times 1,96)} \tag{24}$$

where

$p_{0,mean}$ is the average, in bars, determined from the last 20 initial failure pressure tests performed on pipes manufactured at the factory over an extended period of time;

$p_{0,d}$ is the minimum design pressure, in bars;

NOTE $p_{0,d}$ is designed to give, at 50 years, a 97,5 % lower confidence level failure pressure of not less than $PN \times \eta_t, PN, 97,5\% \text{ LCL}$, in bars.

$$C = p_0 / p_6 \tag{25}$$

where

- p_0 is the mean value, in bars, of the initial failure pressures of pipe test pieces from the same batch of pipes used for the regression test to determine $R_{R,p}$;
- p_6 is the extrapolated 6 min failure pressure value, in bars, from the regression test;
- PN is the nominal pressure, in bars;
- $R_{R,p}$ is the pressure regression ratio, p_{50}/p_6 ;
- p_{50} is the extrapolated 50-year failure pressure value, in bars, from the regression test used to determine the pressure regression ratio, $R_{R,p}$;
- $\eta_{t, PN, 97,5 \% LCL}$ is the safety factor (see Table 16);
- Y is the coefficient of variation (see 3.31), in percent, of the initial failure pressure, p_0 , of pipes manufactured at a factory over an extended period of time;
- 1,96 is the multiplier for a lower confidence level of 97,5 %.

5.2.6.4 Number of test pieces for type testing

When testing in accordance with method A of ISO 8521:1998, use test pieces from three pipes of the same nominal size, nominal stiffness and nominal pressure class.

When testing in accordance with one of methods B or D of ISO 8521:1998, take the appropriate number of test pieces from each of three different samples of the same nominal size, nominal stiffness and nominal pressure class. From each sample, use either one test piece per metre of circumference or five test specimens, whichever gives the greater number of test results.

5.2.6.5 Dimensions of test pieces

5.2.6.5.1 For method A

The length of the test pieces between the end-sealing devices shall be as given in Table 15.

Table 15 — Length of test pieces for method A

Nominal size (DN)	Minimum length mm
≤ 250	$(3 \times DN) + 250$
> 250	$DN + 1000$
NOTE Lengths less than those shown may be used providing the end restraints do not have any effect on the result.	

5.2.6.5.2 For method B

The geometrical characteristics of the test piece shall be as specified in ISO 8521.

5.2.6.5.3 For method C

The width of the test piece shall be 50 mm for helically-wound pipes and 25 mm for non-helically-wound pipes.

5.2.6.5.4 For method D

The width of the test piece shall be 25 mm.

5.2.6.5.5 For method E

The total width, b_{tot} , of the test piece shall be 50 mm.

5.2.6.5.6 For method F

The geometrical characteristics of the test piece shall be as specified in ISO 8521.

5.2.7 Long-term failure pressure

5.2.7.1 General

For pressure pipes (see 3.24), determine the long-term failure pressure in accordance with ISO 7509, using test pieces conforming to 5.2.7.4.

5.2.7.2 Requirement

When determined in accordance with ISO 7509, analysing the results in accordance with ISO 10928, the minimum long-term failure pressure, $p_{x, min}$, at x years (see 4.6) shall not be less than $\eta_{t, 97,5 \% LCL}$ times the nominal pressure (PN) expressed in bars, where $\eta_{t, 97,5 \% LCL}$ has the applicable value in Table 16.

When determined in accordance with ISO 7509, analysing the results in accordance with ISO 10928, the mean long-term failure pressure, $p_{x, mean}$, at x years (see 4.6) shall not be less than $\eta_{t, PN, mean}$ times the nominal pressure (PN) expressed in bars, where $\eta_{t, PN, mean}$ has the applicable value in Table 16.

Carry out the applicable procedures detailed in Annex A to ensure conformity to the minimum safety factor requirements detailed in this subclause.

Table 16 — Minimum values of long-term safety factors $\eta_{t, PN, 97,5 \% LCL}$ and $\eta_{t, PN, mean}$

Pipe to which safety factor is to be applied	PN 32	PN 25	PN 16	PN 10	PN 6	PN 4	PN 2,5
Minimum safety factor, $\eta_{t, PN, 97,5 \% LCL}$, to be applied to the long-term 97,5 % LCL	1,3	1,3	1,45	1,55	1,6	1,65	1,7
Minimum safety factor, $\eta_{t, PN, mean}$, to be applied to the long-term mean	1,6	1,6	1,8	1,9	2,0	2,05	2,1

NOTE 1 The safety factors in this table assume the pipe is buried and operating at a pressure equal to PN and take into account the combined effects of bending and pressure. The values of $\eta_{t, PN, mean}$ are derived assuming a value of 9 % or less for the coefficient of variation of the initial circumferential tensile strength. If the coefficient of variation is greater than this assumed value, then the safety factors have to be increased.

NOTE 2 $\eta_{t, PN, mean}$ is based on a constant safety factor on combined loading (from pressure and bending) of 1,5. See ISO/TR 10465-3 for a fuller explanation.

5.2.7.3 Number of test pieces for determination of the pressure regression ratio, $R_{R,p}$

Take a sufficient number of test pieces for at least 18 failure points to be obtained so that the analysis can be carried out in accordance with method A of ISO 10928:1997.

5.2.7.4 Length of the test pieces

The length of the test pieces between the end-sealing devices shall conform to Table 15.

5.2.7.5 Distribution of failure times

The times to failure of the 18 or more test pieces shall be between 0,1 h and over 10^4 h, and the distribution of ten of these results shall conform to the limits given in Table 13.

5.3 Resistance of pressure pipes to cyclic internal pressure**5.3.1 General**

For pressure pipes (see 3.24), determine the resistance to cyclic internal pressure in accordance with ISO 15306, using test pieces conforming to 5.3.4.

Test pressure pipes that are intended to be used with non-end-load-bearing joints with end-sealing devices that induce only a uni-axial stress in the test pieces. Test pressure pipes that are intended to be used with end-load-bearing joints with end-sealing devices that induce a bi-axial stress in the test pieces.

The mean pressure during the test shall be equal to the nominal pressure expressed in bars. The pressure amplitude shall be equal to $\pm 0,25$ times the nominal pressure expressed in bars, i.e. the specimen shall be cycled between $0,75 \times PN$ and $1,25 \times PN$.

5.3.2 Requirements

When tested in air in accordance with ISO 15306, using water as the pressure-transmitting fluid, the test piece shall not show signs of leakage or weeping for at least 10^6 cycles. The cycling frequency shall be as given in ISO 15306.

5.3.3 Number of test pieces for type testing

Use one test piece.

5.3.4 Length and diameter of the test piece

The length of the test piece between the end-sealing devices shall be as given in Table 15.

The nominal diameter of the test piece shall not exceed DN 600.

5.4 Marking

Marking details shall be printed or formed directly on the pipe in such a way that the marking does not initiate cracks or other types of failure.

If printing is used, the colouring of the printed information shall differ from the basic colouring of the product and the printing shall be such that the marking is readable without magnification.

The following marking shall be on the outside of each pipe:

- a) the number of this International Standard;

- b) the nominal size (DN) and the diameter series, e.g. A, B1, B2;
- c) the stiffness rating in accordance with Clause 4 of this International Standard;
- d) the pressure rating in accordance with Clause 4 of this International Standard;
- e) for pipes intended for the conveyance of drinking water, the code-letter "P";
- f) the manufacturer's name or identification;
- g) the date of manufacture, in plain text or code;
- h) the code-letter "R" to indicate that the pipe is suitable for use with axial loading, if applicable.

6 Fittings

6.1 All types

6.1.1 General

In addition to the particular requirements detailed for each type of fitting, all fittings shall conform to the requirements specified in 6.1.2 to 6.1.9.

6.1.2 Diameter series

The diameter series of the fitting shall be that of the straight length(s) of pipe to which the fitting is to be joined in the piping system.

6.1.3 Nominal pressure (PN)

The nominal pressure rating (PN) of the fitting shall be selected from the values given in Clause 4 of this International Standard and shall not be less than that of the straight pipe(s) to which the fitting is to be joined in the piping system.

6.1.4 Nominal stiffness (SN)

The nominal stiffness rating (SN) of the fitting shall be selected from the values given in Clause 4 of this International Standard.

NOTE For a given material, a fitting for which the wall thickness and construction is the same as a pipe of the same diameter will have a stiffness equal to or greater than that of the pipe. This is due to the geometry of the fitting. Hence it is not necessary to test such fittings.

6.1.5 Joint type

The type of joint shall be designated as flexible or rigid as defined in 3.57 or 3.58, and whether or not it is end-load-bearing.

6.1.6 Pipe type

The type(s) of pipe with which the fitting is intended to be used shall be indicated, i.e. whether or not the pipes are suitable for resisting the longitudinal load produced by internal pressure.

6.1.7 Mechanical characteristics of fittings

Fittings shall be designed and manufactured in accordance with relevant design practices to have a mechanical performance equal to or greater than that of a straight GRP pipe of the same pressure and stiffness rating when installed in a piping system and, if appropriate, supported by anchor blocks or encasements.

The manufacturer of the fitting shall document their fitting design and manufacturing procedures.

6.1.8 Installed leaktightness of fittings

Where a specific site installation test is declared by the purchaser or is agreed between the manufacturer and the purchaser, the fitting and its joints shall be capable of withstanding that test without leakage.

6.1.9 Alternative dimensions

The broad design and process flexibility afforded by GRP materials makes it difficult to totally standardize GRP fitting dimensions. The tolerances and dimensions that are specified as minima in 6.2 to 6.6 shall be taken as only being indicative of common practice, and other dimensions and tolerances may be supplied by declaration and agreement between purchaser and manufacturer.

6.2 Bends

6.2.1 Classification of bends

6.2.1.1 General

Bends shall be designated in respect of the following:

- a) the nominal size (DN);
- b) the diameter series, e.g. A, B1, B2;
- c) the nominal pressure (PN);
- d) the nominal stiffness (SN);
- e) the joint type, i.e. flexible or rigid and whether or not end-load-bearing;
- f) the fitting angle, in degrees;
- g) the bend type, i.e. moulded or fabricated;
- h) the pipe type, if applicable.

6.2.1.2 Nominal size (DN)

The nominal size (DN) of the fitting shall be that of the straight length of pipe to which it is to be joined in the piping system and shall be one of the nominal sizes given in Table 3.

6.2.1.3 Bend type

The type of bend shall be designated as either moulded or fabricated, as shown in Figure 2 and Figure 3.

6.2.2 Dimensions and tolerances of bends

6.2.2.1 Tolerance on diameter

The tolerance on the diameter of the bend at the spigot positions shall conform to 5.1.1.4.

6.2.2.2 Fitting angle and angular tolerances

The fitting angle, α , is the angular change in direction of the axis of the bend (see Figure 2 and Figure 3).

The deviation of the actual change in direction of a bend shall not exceed either $(\alpha \pm 0,5)^\circ$ if the joint is flanged or $(\alpha \pm 1)^\circ$ for all other types of joint in which it is intended to be used.

NOTE In the interests of rationalization, preferred values for the fitting angles of bends are 11,25°, 15°, 22,5°, 30°, 45°, 60° and 90°, but fitting angles other than these may be supplied by agreement between the purchaser and the manufacturer.

6.2.2.3 Radius of curvature, R

6.2.2.3.1 Moulded bends

The radius of curvature, R , of moulded bends (see Figure 2) shall not be less than the nominal size (DN), in millimetres, of the pipe to which the bend is to be joined in the piping system.

The dimensions specified for bends in this International Standard are based on a radius of curvature, R , of $1,5 \times \text{DN}$, in millimetres. The dimensions of a bend shall comply either with the values in this International Standard or with values agreed between the purchaser and the manufacturer.

6.2.2.3.2 Fabricated bends

Bends made by fabrication from straight pipe (see Figure 3) shall not provide more than 30° angular change for each segment of the bend. The base of each segment shall have sufficient length adjacent to each joint to ensure that external wrapping can be accommodated.

The radius of curvature, R , of fabricated bends shall not be less than the nominal size (DN), in millimetres, of the pipe to which the bend is to be joined in the piping system.

The dimensions specified for bends in this International Standard are based on a radius of curvature, R , of $1,5 \times \text{DN}$, in millimetres. The dimensions of a bend shall comply either with the values in this International Standard or with values agreed between the purchaser and the manufacturer.

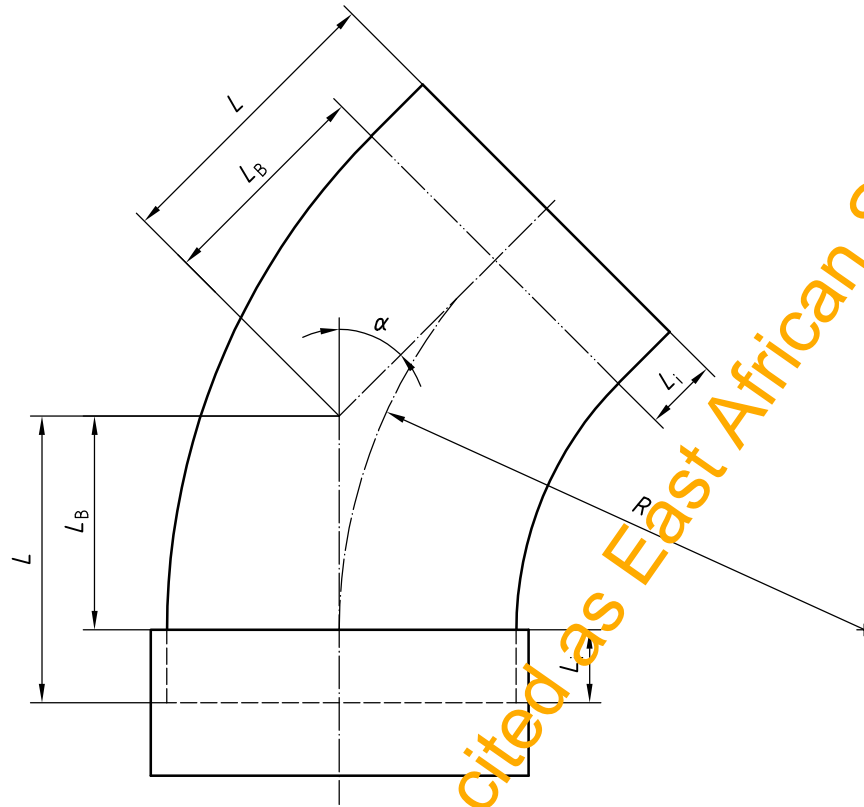
**Key**

- L_B body length
- L laying length
- L_i insertion depth
- α fitting angle
- R radius of curvature

Figure 2 — Typical moulded bend

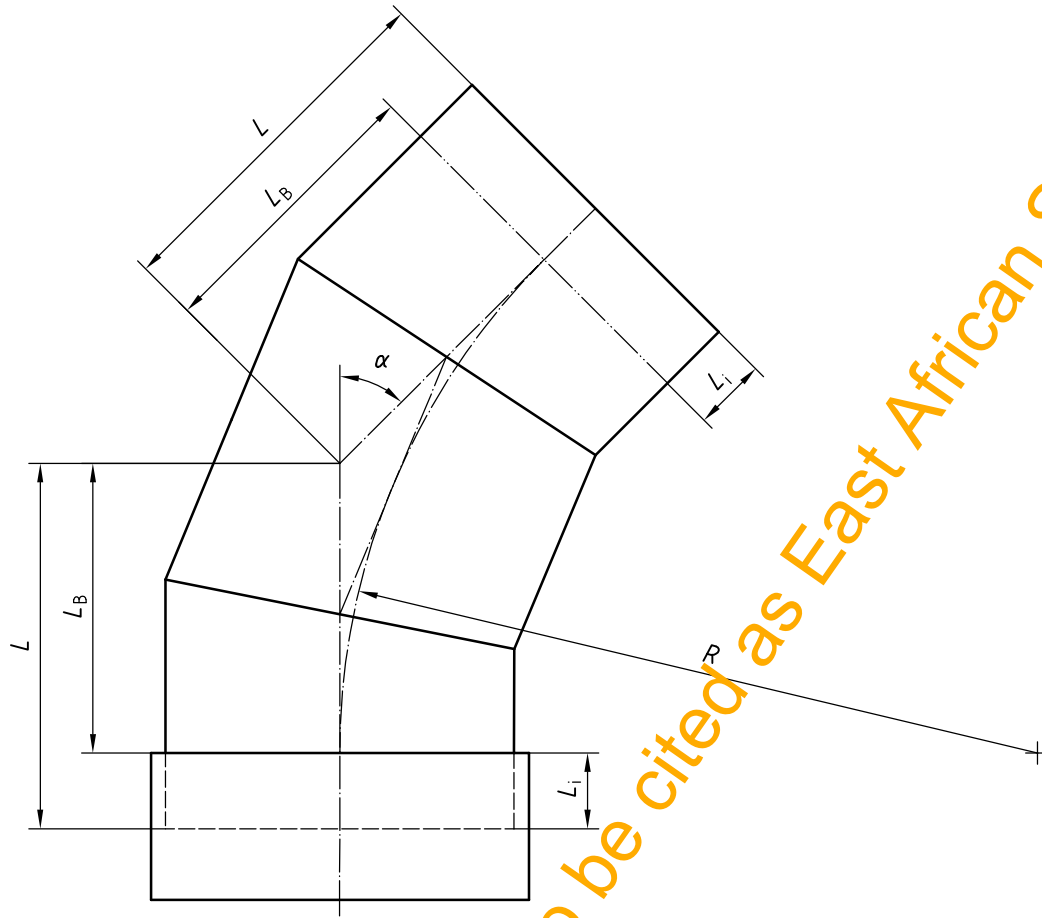

Key

- L_B body length
- L laying length
- L_i insertion depth
- α fitting angle
- R radius of curvature

Figure 3 — Typical fabricated bend

6.2.2.4 Length

6.2.2.4.1 General

Lengths of individual bends are dependent upon the designated fitting angle, the radius of curvature, and the length of any linear extensions provided for jointing or other purposes. The declared or specified laying length, L (see 6.2.2.4.2), shall conform to the tolerances given in 6.2.2.4.4.

Minimum body lengths shall be taken from Table 17 for both moulded and fabricated bends. Values other than those given in Table 17 may be used by agreement between the purchaser and the manufacturer.

Table 17 — Minimum body length, L_B , for bends (see Figures 2 and 3)

DN	Fitting angle, α						
	90°	60°	45°	30°	22,5°	15°	11,25°
	Minimum body length, L_B mm						
100	155	90	65	45	35	25	20
125	190	110	80	55	40	30	20
150	230	135	95	65	50	35	25
200	305	180	130	85	65	45	35
250	380	225	160	105	80	55	45
300	455	265	190	125	95	65	50
350	530	310	225	145	110	75	60
400	605	350	255	165	125	85	65
450	680	395	285	185	140	95	70
500	755	440	315	205	155	105	80
600	905	525	380	245	185	125	95
700	1 055	615	440	290	215	145	105
800	1 205	700	505	330	245	165	125
900	1 355	785	565	370	275	185	140
1000	1 505	875	670	410	305	200	155

6.2.2.4.2 Laying length

The laying length, L , of the bend shall be taken as the distance from one end of the bend, excluding the spigot insertion depth or a socket end where applicable, projected along the axis of that end of the bend to the point of intersection with the axis of the other end of the bend.

For an end of a bend containing a spigot, the laying length, L , shall be taken as the body length, L_B , plus the insertion depth, L_i (see Figure 3).

6.2.2.4.3 Body length

The body length of the bend, L_B , shall be taken as the distance, from the point of intersection of the two axes of the bend to a point on either axis, equal to the laying length minus one insertion depth, L_i . The values in Table 17 are minimum lengths, which are determined by the fitting geometry and may need to be increased to provide sufficient length for over-wraps at the mitres and joints.

6.2.2.4.4 Tolerances on laying length

For moulded bends, the permitted deviation of the laying length from the declared value is $(L \pm 25)$ mm.

For fabricated bends, the permitted deviation of the laying length from the declared value is $[L \pm (15 \times \text{the number of mitres of the bend})]$, in millimetres.

6.3 Branches

6.3.1 Classification of branches

6.3.1.1 General

Branches shall be designated in respect of the following:

- a) the nominal size (DN);
- b) the diameter series, e.g. A, B1, B2;
- c) the nominal pressure (PN);
- d) the nominal stiffness (SN);
- e) the joint type, i.e. flexible or rigid and whether or not end-load-bearing;
- f) the fitting angle, in degrees;
- g) the branch type, i.e. moulded or fabricated;
- h) the pipe type, if applicable.

6.3.1.2 Nominal size (DN)

The nominal size (DN) of the fitting shall be that of the straight length of pipe to which the fitting is to be joined in the piping system and shall be one of the nominal sizes given in Table 3.

6.3.1.3 Fitting angle

The fitting angle, α , which is the angular change in direction of the axis of the branch (see Figure 4), shall be 90° for pressure pipes.

6.3.1.4 Branch type

The type of branch shall be designated as shown in Figure 4.

6.3.2 Dimensions and tolerances of branches

6.3.2.1 Tolerances on diameter

The tolerances on the diameter of the branch at the spigot positions shall conform to 5.1.1.4 of this International Standard.

6.3.2.2 Angular tolerances

Any deviation from the declared change in direction of a branch shall not exceed either $(\alpha \pm 0,5)^\circ$ if the joint is flanged or $(\alpha \pm 1)^\circ$ for all other types of joint with which the branch is intended to be used.

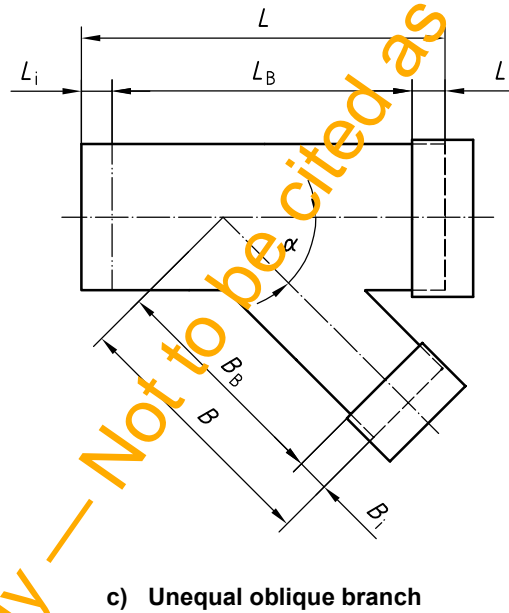
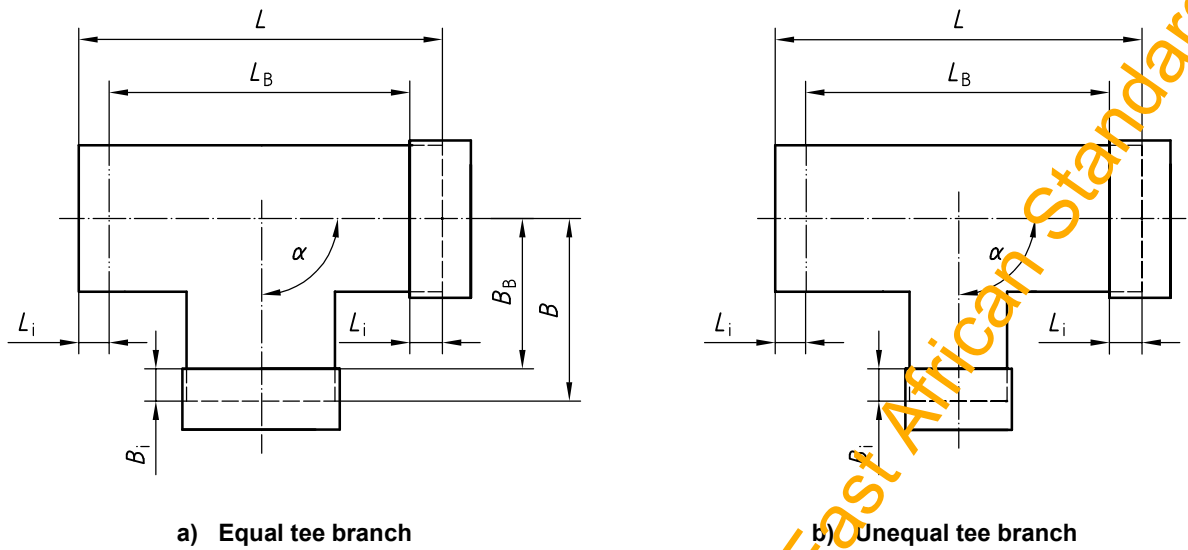

Key

- α fitting angle
- B laying length of branch pipe
- B_B offset length of branch pipe
- B_i spigot insertion depth of branch pipe
- L laying length of main pipe
- L_B body length of main pipe
- L_i spigot insertion depth of main pipe

Figure 4 — Typical branches

6.3.2.3 Length

6.3.2.3.1 General

NOTE Only tee branches are covered by the dimensional requirements in this International Standard.

Dimensions other than those specified can be used by agreement between the purchaser and the manufacturer (see 6.1.9).

6.3.2.3.2 Body length

6.3.2.3.2.1 General

The body length, L_B , of the fitting (see Figure 4) shall be equal to the laying length of the main pipe minus two insertion depths, L_i .

6.3.2.3.2.2 Moulded tee branches

The body length, L_B , of moulded equal tees shall not be less than the applicable value given in Table 18.

Table 18 — Minimum body length, L_B , of moulded equal tees

DN	L_B mm	DN	L_B mm
100	206	150	650
125	220	500	700
150	290	600	800
200	360	700	900
250	430	800	1 000
300	510	900	1 120
350	540	1000	1 220

6.3.2.3.2.3 Fabricated tee branches

For fabricated equal tees, the minimum body length, L_B , shall be as follows:

- a) 750 mm for $DN \leq 250$;
- b) 1 250 mm for $250 > DN \leq 600$;
- c) 1 750 mm for $600 > DN \leq 1000$.

6.3.2.3.3 Offset length

The offset length, B_B , of the branch pipe (see Figure 4) shall be taken as the distance from the end of the branch pipe (excluding, where applicable, the spigot insertion depth) to the point of intersection of the straight-through axis of the fitting with the extended axis of the branch pipe.

The offset length, B_B , of the branch pipe of equal tee branches shall be 50 % of the body length, L_B .

6.3.2.3.4 Laying length

For the main pipe of a branch containing a spigot and a socket, the laying length, L , is the body length, L_B , plus the insertion depth, L_i , at the spigot end (see Figure 4). For the main pipe of a branch containing two spigots, the laying length, L , is the body length, L_B , plus two insertion depths, L_i .

6.3.2.3.5 Tolerances on length

6.3.2.3.5.1 Branches for use with rigid joints

The permissible deviation from the manufacturer's declared offset length and body length of the branch is given in Table 19.

Table 19 — Deviation from declared length of branches for use with rigid joints

Nominal size (DN)	Limits of deviation from declared length
	mm
$100 \leq \text{DN} < 300$	$\pm 1,5$
$300 \leq \text{DN} < 600$	$\pm 2,5$
$600 \leq \text{DN} \leq 1000$	$\pm 4,0$

6.3.2.3.5.2 Branches for use with flexible joints

The permissible deviation from the manufacturer's declared offset length and body length of the branch is ± 25 mm or ± 1 % of the laying length, whichever is the larger.

6.4 Reducers

6.4.1 Classification of reducers

6.4.1.1 General

Reducers shall be designated in respect of the following:

- the nominal sizes (DN 1 and DN 2);
- the diameter series, e.g. A, B1, B2;
- the nominal pressure (PN);
- the nominal stiffness (SN);
- the joint type, i.e. flexible or rigid and whether or not end-load-bearing;
- the reducer type, i.e. concentric or eccentric;
- the pipe type, if applicable.

6.4.1.2 Nominal size (DN)

The nominal sizes DN₁ and DN₂ of the reducer shall be the same as those of the straight lengths of pipe to which it is to be joined in the piping system and shall conform to the nominal sizes given in Table 3.

6.4.1.3 Reducer type

The type of reducer shall be designated as either concentric or eccentric (see Figure 5).

6.4.2 Dimensions and tolerances of reducers

6.4.2.1 Tolerance on diameter

The tolerance on the diameter of the reducer at the spigot positions shall conform to 5.1.1.4 of this International Standard.

6.4.2.2 Wall thickness

6.4.2.2.1 Except where 6.4.2.2.2 applies, the wall thickness of the tapered section of the reducer shall not be less than the greater of the following:

- a) the dimension given in Table 20 for the nominal size (DN) of the larger-diameter straight section (DN₁ in Figure 5);
- b) the wall thickness determined using Equation (29):

$$e_{\min} = 6 \times \frac{p}{2} \times \frac{d_i}{0,01 \times \sigma_t} \tag{29}$$

where

- 6 is a safety factor,
- p is the internal pressure corresponding to the nominal pressure, expressed in bars,
- d_i is the internal diameter of the larger-diameter straight section (DN₁ in Figure 5), expressed in metres,
- e_{min} is the minimum wall thickness of the tapered section of the reducer, expressed in millimetres,
- σ_t is the short-term circumferential tensile strength of the tapered section (see 6.4.2.4), expressed in newtons per square millimetre.

6.4.2.2.2 If a manufacturer wishes to use thicknesses less than those given in 6.4.2.2.1, then they shall prove that the performance of the laminate is proportionately higher than the value given in 6.4.2.4.

6.4.2.3 Length

6.4.2.3.1 General

The lengths L_{DB} and L_T in Figure 5 shall be as declared by the manufacturer and be subject to the tolerances given in 6.4.2.3.5.

6.4.2.3.2 Laying length

The laying length, L, of the reducer shall be taken as the total length, excluding the spigot insertion depth of a socket end, where applicable.

6.4.2.3.3 Body length

The body length, L_B , of the reducer (see Figure 5) is the laying length, L , minus two spigot insertion depths, L_i .

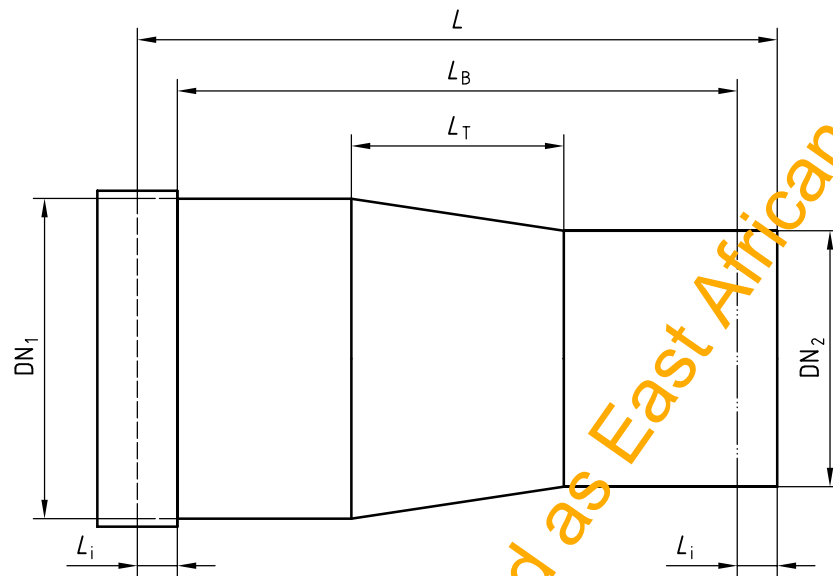

a) Concentric reducer

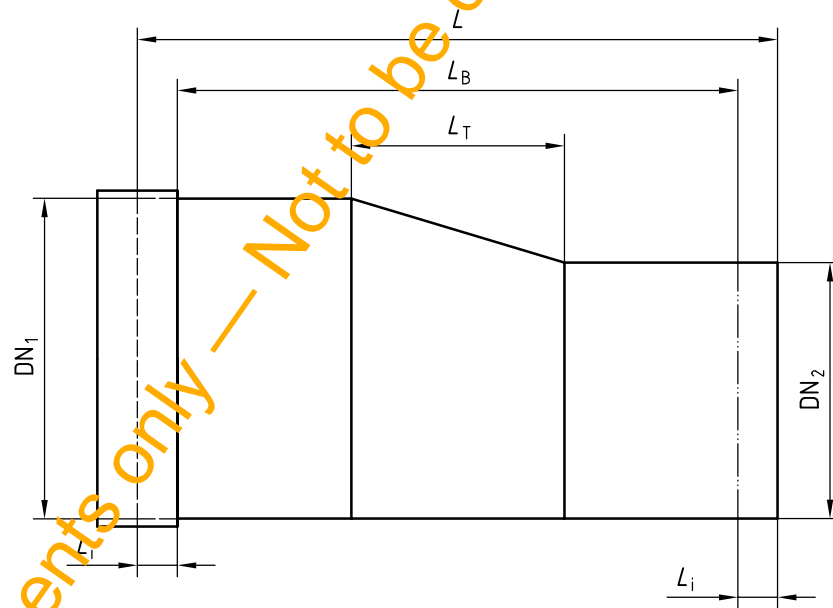

b) Eccentric reducer

Key

- L laying length
- L_B body length
- L_T length of tapered section
- L_i spigot insertion depth
- DN_1 larger nominal size
- DN_2 smaller nominal size

Figure 5 — Concentric and eccentric reducers

Table 20 — Minimum wall thickness for reducers (see 6.4.2.2)

Nominal size (DN)	Minimum wall thickness (mm)	Nominal size (DN)	Minimum wall thickness (mm)
300 or less	2,8	1600	15,0
350	3,3	1700	15,6
400	3,8	1800	16,9
450	4,2	1900	17,8
500	4,7	2000	18,8
600	5,6	2100	19,7
700	6,6	2200	20,6
800	7,5	2300	21,6
900	8,4	2400	22,5
1000	9,4	2500	23,4
1100	10,3	2600	24,4
1200	11,3	2700	25,3
1300	12,2	2800	26,3
1400	13,1	2900	27,2
1500	14,1	3000	28,1

NOTE 1 The above minimum wall thicknesses only apply for nominal pressures up to PN 2,5. For higher pressures, use Equation (29) to determine the applicable minimum wall thickness.

NOTE 2 The above wall thicknesses assume an initial circumferential tensile strength, σ_t , of 80 N/mm².

6.4.2.3.4 Length of tapered section

The length, L_T , of the tapered section (see Figure 5) shall not be less than $1,5 \times (DN 1 - DN 2)$, expressed in millimetres.

NOTE For reasons of hydraulic capacity, it is normal practice when designing a non-pressure eccentric reducer for L_T to be lower than that for an equivalent concentric reducer.

6.4.2.3.5 Tolerances on laying lengths

6.4.2.3.5.1 Reducers for use with rigid joints

The permissible deviation from the manufacturer's declared laying length, L , of the reducer is as given in Table 19 for branches.

6.4.2.3.5.2 Reducers for use with flexible joints

The permissible deviation from the manufacturer's declared laying length, L , of the reducer is $(L \pm 50)$ mm or $(L \pm 1) \%$, whichever is the greater.

6.4.2.4 Mechanical characteristics of tapered-section laminate

To verify the properties of the laminate used in the tapered section, make panels using the same materials and lay up as used for the tapered section of the reducer.

When tested in accordance with ISO 527-4 or ISO 527-5, as applicable, test pieces taken from the panel shall have an initial circumferential tensile strength, σ_t , of at least 80 N/mm².

6.5 Saddles

6.5.1 Classification of saddles

6.5.1.1 General

Saddles shall be designated in respect of the following:

- a) the nominal size (DN);
- b) the diameter series, e.g. A, B1, B2;
- c) the nominal pressure (PN);
- d) the joint type, i.e. flexible or rigid and whether or not end-load-bearing;
- e) the fitting angle, α ;
- f) the pipe type, if applicable.

6.5.1.2 Nominal size (DN)

The nominal size (DN) of the saddle shall be a combination of the nominal size of the main pipe to which it is to be connected in the pipeline and the nominal size of the branch pipe. The nominal size of the main pipe shall be one of the nominal sizes given in Table 3. The nominal size of the branch pipe shall be one of those given in the appropriate standard for the pipe to which the branch pipe is to be joined.

NOTE The designation DN 600/150 indicates a saddle for connecting a DN 150 branch line to a DN 600 pipeline.

6.5.1.3 Fitting angle

The fitting angle, α , is the nominal angular change in direction of the axis of the saddle (see Figure 6).

6.5.2 Dimensions of saddles and associated tolerances

6.5.2.1 Tolerance on diameter

The tolerance on the diameter of the branch pipe at the joint position shall conform to 5.1.1.4 of this International Standard, if applicable.

6.5.2.2 Length

The length of the branch, L_B , depends upon the fitting angle, α , and the length provided for jointing or other purposes. The length of the branch pipe shall not normally be less than 300 mm, although other lengths may be used by agreement between the purchaser and the manufacturer.

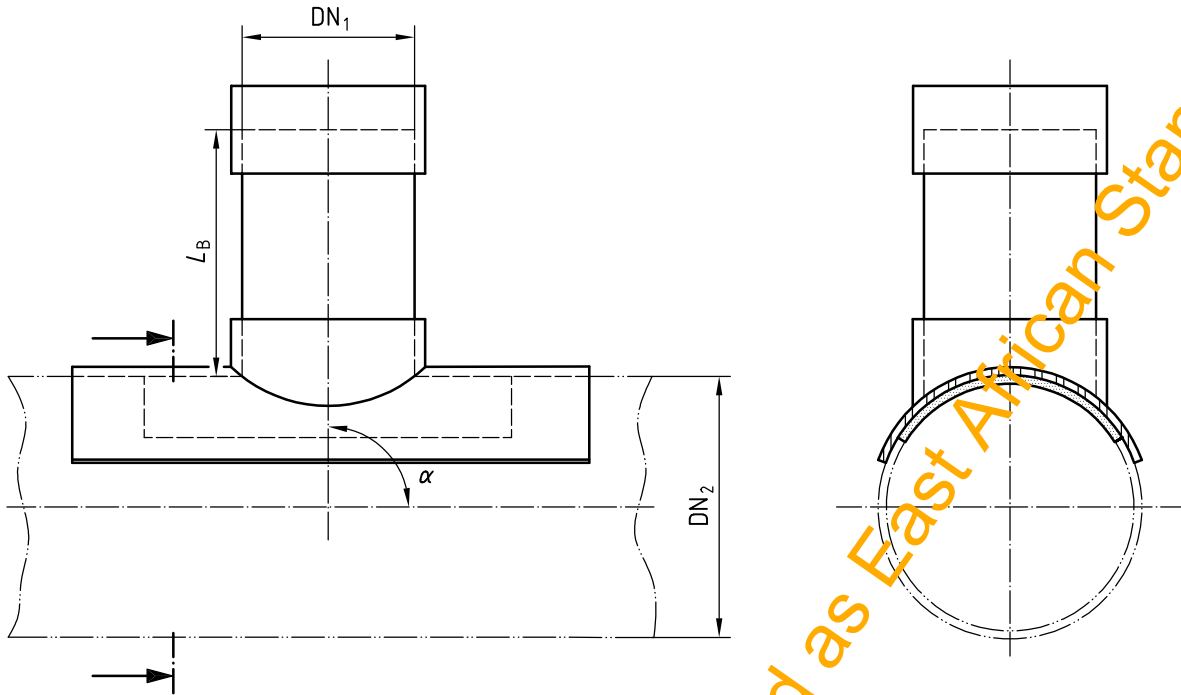

Key

- DN₁ nominal size of branch pipe
- DN₂ nominal size of main pipe
- L_B length of branch pipe
- α fitting angle

Figure 6 — Typical non-pressure saddle

6.6 Flanged adaptors

6.6.1 Classification of flanged adaptors

6.6.1.1 General

Flanged adaptors shall be designated in respect of the following:

- a) the nominal size (DN);
- b) the diameter series, e.g. A, B1, B2;
- c) the nominal pressure (PN);
- d) the nominal stiffness (SN);
- e) the joint type, i.e. flexible or rigid and whether or not end-load-bearing;
- f) the flange drilling;
- g) the pipe type, if applicable.

6.6.1.2 Nominal size (DN)

The nominal size (DN) of the fitting shall be that of the straight length of pipe to which it is to be joined in the piping system and shall be one of the nominal sizes given in Table 3.

6.6.1.3 Flange designation

The mating characteristics of the flange shall conform to the purchaser's requirements, e.g. bolt circle, bolt hole diameter, flat or raised face, flange O.D. and washer diameter.

NOTE Flanges are frequently specified by reference to a specification that includes PN. This PN is not necessarily the same as the PN for the flange adaptor.

The joint manufacturer shall supply full information on the flange, the gasket, the bolt torque, the degree and nature of the bolt lubrication, and the bolt-tightening sequence.

6.6.2 Dimensions of flanged adaptors and associated tolerances

6.6.2.1 Tolerance on diameter

The tolerance on the diameter of the flanged adaptor at the spigot position, if applicable, shall conform to 5.1.1.4 of this International Standard.

6.6.2.2 Wall thickness

The wall thickness of the adaptor shall nowhere be less than the minimum wall thickness of the pipe with which the adaptor is intended to be used.

6.6.2.3 Length

The length, L , of the fitting (see Figure 7) shall not be less than the value given in Table 21. The manufacturer shall declare the actual length.

NOTE The length of a flanged adaptor depends upon the diameter, loading requirements and method of manufacture.

Table 21 — Minimum lengths, L , of flanged adaptors

DN	L mm	DN	L mm	DN	L mm
100	100	300	250	600	350
125	150	350	250	700	400
150	150	400	300	800	400
200	200	450	300	900	450
250	200	500	350	1000	500

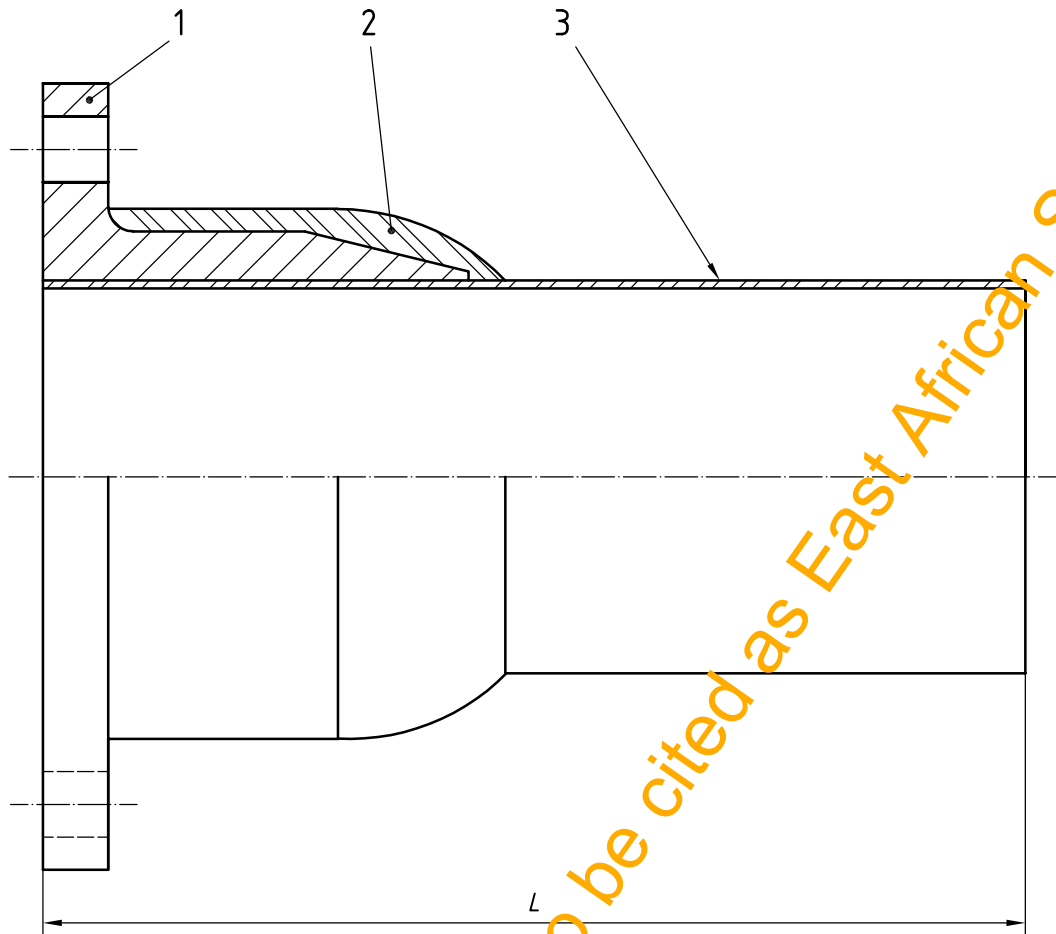

Key

- 1 flange
- 2 GRP over-wrapping
- 3 spigot
- L length of adaptor

Figure 7 — Flanged adaptor

6.6.2.3.1 Tolerances on length

6.6.2.3.1.1 Flanged adaptors for use with rigid joints

The permissible deviation from the manufacturer's declared length of the fitting, L , is given in Table 22.

6.6.2.3.1.2 Flanged adaptors for use with flexible joints

The permissible deviation from the manufacturer's declared length of the fitting is $(L \pm 25)$ mm.

Table 22 — Deviation from declared length of adaptors for use with rigid joints

Nominal size (DN)	Limits of deviation from declared length
	mm
$DN \leq 400$	± 2
$400 < DN \leq 600$	± 5
$600 < DN$	± 10

6.7 Marking

Marking details shall be printed or formed directly on the fitting in such a way that the marking does not initiate cracks or other types of failure.

If printing is used, the colouring of the printed information shall differ from the basic colouring of the product and the printing shall be such that the marking is readable without magnification.

The following marking shall be on the outside of each fitting:

- a) the number of this International Standard;
- b) the nominal size (DN) and the diameter series, e.g. A, B1, B2;
- c) for bends, branches and saddles, the designated fitting angle;
- d) for reducers, the nominal sizes DN_1 and DN_2 ;
- e) the stiffness rating in accordance with Clause 4 of this International Standard;
- f) the pressure rating in accordance with Clause 4 of this International Standard;
- g) the joint type in accordance with Clause 4 of this International Standard, and whether or not it is end-load-bearing;
- h) for fittings intended for the conveyance of drinking water, the code-letter "P";
- i) the manufacturer's name or identification;
- j) the date of manufacture, in plain text or code;
- k) the code-letter "R" to indicate that the fitting is suitable for use with axial loading, if applicable.

7 Joint performance

7.1 General

7.1.1 Interchangeability

Where interchangeability between products from different suppliers is required, the purchaser shall ensure that the pipe and fitting dimensions are compatible with the components to be joined and that the performance of the joint formed conforms to the relevant performance requirements in this clause.

7.1.2 Requirements

A joint made between pipes conforming to Clause 5 and/or fittings conforming to Clause 6 shall be designed so that its performance is equal to or better than the requirements of the piping system, but not necessarily of the components being joined.

7.1.3 Dimensions

All dimensions which may influence the performance of the joints tested shall be recorded.

7.2 Flexible joints

7.2.1 General

For each design of joint, the maximum allowable values of draw, D (see 3.54 and Figure 1), total draw, T (see 3.55 and Figure 1), and angular deflection, δ (see 3.53 and Figure 1), for which the joint has been designed to be used shall be as declared by the manufacturer.

7.2.2 Maximum allowable draw

The manufacturer's maximum declared allowable draw, D , which shall include Poisson contraction and temperature effects, shall not be less than 0,3 % of the laying length of the longest pipe which it is intended to use in the case of pressure pipes and 0,2 % in the case of non-pressure pipes.

7.2.3 Maximum allowable angular deflection

The manufacturer's declared maximum allowable angular deflection, δ , shall not be less than the value given in 4.7.3.1 for the particular piping system concerned.

7.2.4 Flexible non-end-load-bearing joints with elastomeric sealing rings

7.2.4.1 General

Flexible non-end-load-bearing joints with elastomeric seals shall be tested, using test pieces conforming to 7.2.4.4, for conformity to the requirements for performance under hydrostatic pressure detailed in 7.2.4.2, using methods of test given in ISO 8639, as appropriate, in conjunction with specific conditions dependent upon the nominal pressure (PN) of the piping system in which the particular type of joint is to be used. Specific values of PN are given in 4.1.4.

7.2.4.2 Performance requirements

7.2.4.2.1 Initial leaktightness test following assembly

When assembled in accordance with the pipe manufacturer's recommendations, the joint shall withstand without leakage an internal pressure of $1,5 \times \text{PN}$ bar for 15 min, and shall subsequently conform to 7.2.4.2.2, 7.2.4.2.3, 7.2.4.2.4 and 7.2.4.2.5.

Failure at the end closures shall not constitute failure of the test.

7.2.4.2.2 Leaktightness when subjected to a negative pressure at maximum draw

When the joint is subjected to the manufacturer's declared maximum allowable draw, D (see 7.2.2), it shall not show any visible signs of damage to its components nor exhibit a change in pressure greater than 0,08 bar/h (0,008 MPa/h) when tested by the appropriate method given in ISO 8639 at the pressure given in Table 23.

7.2.4.2.3 Leaktightness when simultaneously subjected to angular deflection and draw

When the joint is subjected to the manufacturer's declared maximum allowable angular deflection in accordance with 7.2.3 and a total draw, T , equal to the manufacturer's declared maximum allowable draw, D (see 7.2.2), plus the longitudinal movement, J (see 3.55 and Figure 1), resulting from application of the manufacturer's declared allowable angular deflection, it shall not show any visible signs of damage to its components nor leak when tested by the appropriate method given in ISO 8639 at the pressures given in Table 23.

7.2.4.2.4 Leaktightness when simultaneously subjected to misalignment and draw under static pressure

When the joint is subjected to the manufacturer's declared maximum allowable draw, D (see 7.2.2), and a total force, F , of 20 N per millimetre of the nominal size (DN) in millimetres, it shall not show any visible sign of damage to its components nor leak when tested by the appropriate method given in ISO 8639 at the pressures given in Table 23.

7.2.4.2.5 Leaktightness when subjected to misalignment and draw under a cyclic pressure

When the joint is subjected to the manufacturer's declared maximum allowable draw, D (see 7.2.2), and a total force, F , of 20 N per millimetre of the nominal size (DN) in millimetres, it shall not show any visible sign of damage to its components nor leak when tested by the appropriate method given in ISO 8639 at the positive cyclic pressure given in Table 23.

Table 23 — Summary of test requirements for flexible non-end-load-bearing joints

Test	Pressure sequence	Test pressure bar	Duration
Initial leaktightness test (ISO 8639:2000, 7.2)	Initial pressure	$1,5 \times PN$	15 min
External pressure differential (ISO 8639:2000, 7.3)	Negative pressure ^a	– 0,8 bar (– 0,08 MPa)	1 h
Misalignment and draw under static pressure (ISO 8639:2000, 7.5)	Positive static pressure	$2,0 \times PN$	24 h
Misalignment and draw under cyclic pressure (ISO 8639:2000, 7.6)	Positive cyclic pressure	Atmospheric to $1,5 \times PN$ and back to atmospheric	10 cycles of 1,5 min to 3 min each
Angular deflection and draw (ISO 8639:2000, 7.4)	Initial pressure	$1,5 \times PN$	15 min
	Positive static pressure	$2,0 \times PN$	24 h

^a Relative to atmospheric, i.e. approximately 0,2 bar (0,02 MPa) absolute.

7.2.4.3 Number of test pieces for type testing

The number of joint assemblies to be tested for each test shall be one.

It is permissible for the same assembly to be used for more than one of the tests detailed in Table 23.

7.2.4.4 Test pieces

A test piece shall comprise a joint and two pieces of pipe such that the total laying length, L , is not less than the applicable value given in Table 15 or that which is necessary to meet the requirements of the test method.

7.2.5 Flexible end-load-bearing joints with elastomeric sealing rings

7.2.5.1 General

Flexible end-load-bearing joints, including locked socket-and-spigot joints, with elastomeric seals, shall be tested, using test pieces conforming to 7.2.5.4, for conformity to the requirements for performance under hydrostatic pressure detailed in 7.2.5.2, using methods of test given in ISO 7432,^{2), 3)} in conjunction with specific conditions, detailed in Table 24, dependent upon the nominal pressure (PN) of the piping system in which the particular type of joint is to be used. Specific values for PN are given in 4.1.4.

7.2.5.2 Performance requirements

7.2.5.2.1 Initial leaktightness test following assembly

When assembled in accordance with the pipe manufacturer's recommendations and subjected to a static-pressure test in accordance with ISO 7432, using a test pressure equal to $1,5 \times \text{PN}$ bar for 15 min, the joint shall remain leaktight and there shall be no visible damage to the joint components.

7.2.5.2.2 Leaktightness when subjected to a pressure differential

When subjected to a negative-pressure test in accordance with ISO 7432, using a test pressure of $-0,8$ bar ($-0,08$ MPa), i.e. approximately $0,2$ bar ($0,02$ MPa) absolute, for 1 h, the joint shall not show any visible signs of damage to its components nor shall there be a change in pressure greater than $0,08$ bar/h ($0,008$ MPa/h).

7.2.5.2.3 Misalignment with internal pressure and end thrust

When subjected to a static-pressure misalignment test in accordance with the appropriate method given in ISO 7432, whilst subjected to a total force, F_1 , of 20 N per millimetre of the nominal size expressed in millimetres, using a test pressure equal to $2,0 \times \text{PN}$ bar, for 24 h, the joint shall remain leaktight and there shall be no visible damage to the joint components.

When subjected to a positive cyclic pressure misalignment test in accordance with ISO 7432, whilst subjected to a total force, F_1 , of 20 N per millimetre of the nominal size expressed in millimetres and to ten cycles, of 1,5 min to 3 min each, between atmospheric pressure and $1,5 \times \text{PN}$ bar, the joint shall remain leaktight and there shall be no visible damage to the joint components.

2) ISO 7432 refers to locked socket-and-spigot joints as rigid, but in this International Standard they are classified as flexible.

3) ISO 7432 has a transverse bending test with specified bending load and support conditions, but some special installation conditions may require more severe loads and support conditions to be used. In countries where such special installation conditions are known to exist, the test loads and support conditions required shall be detailed in the national foreword.

7.2.5.2.4 Short-term resistance to internal pressure

When subjected to a short-term static-pressure test in accordance with ISO 7432, using a test pressure equal to $3,0 \times PN$ bar, for 6 min, the joint shall remain leaktight and there shall be no visible damage to the joint components.

7.2.5.2.5 Resistance to bending for pipes up to and including DN 600

With the joint at the manufacturer's declared allowable angular deflection, subject it to the bending test in accordance with ISO 7432, using a test pressure equal to $2,0 \times PN$ bar, for 24 h. The joint shall remain leaktight and there shall be no visible damage to the joint components.

7.2.5.3 Number of test pieces for type testing

The number of joint assemblies to be tested for each test shall be one.

It is permissible for the same assembly to be used for more than one of the tests detailed in Table 24.

7.2.5.4 Test pieces

A test piece shall comprise a joint and two pieces of pipe such that the total laying length, L , is not less than the value given in Table 15 or that which is necessary to meet the requirements of the test method.

Table 24 — Summary of test requirements for flexible end-load-bearing joints

Test	Pressure sequence	Test pressure bar	Duration
Initial leaktightness test (ISO 7432:2002, 7.3)	Initial pressure	$1,5 \times PN$	15 min
External pressure differential (ISO 7432:2002, 7.2)	Negative pressure	$- 0,8$ bar ($- 0,08$ MPa)	1 h
Misalignment with internal pressure (ISO 7432:2002, 7.4)	Maintained pressure	$2,0 \times PN$	24 h
	Positive cyclic pressure	Atmospheric to $1,5 \times PN$ and back to atmospheric	10 cycles of 1,5 min to 3,0 min each
Resistance to bending (ISO 7432:2002, 7.5)	Preliminary pressure	$1,5 \times PN$	15 min
	Maintained pressure	$2,0 \times PN$	24 h
Short-term resistance to internal pressure (ISO 7432:2002, 7.6)	Maintained pressure	$3,0 \times PN$	6 min
NOTE Nominal pressure (PN) is an alphanumeric designation of pressure related to the resistance of a component of a piping system to internal pressure.			

7.3 Rigid joints

7.3.1 Wrapped or cemented

7.3.1.1 General

Wrapped or cemented joints shall be tested for conformity to the requirements for performance under hydrostatic pressure detailed in 7.3.1.2 and Table 25, using test pieces conforming to 7.3.1.4. The methods of

test shall be those given in ISO 8533⁴⁾, in conjunction with specific conditions dependent upon the nominal pressure (PN) for the piping system in which the particular type of joint is to be used. Specific values for PN are given in 4.1.4.

For joints intended to be capable of resisting end loads, the tests shall be performed with the joint subject to the load from the end thrust. For joints not intended to be capable of resisting end loads, the tests shall be performed with the load from the end thrust carried by external supports.

Table 25 — Summary of test requirements for wrapped or cemented joints

Test	Pressure sequence	Test pressure bar	Duration
Initial leakage (ISO 8533:2003, 7.3)	Initial pressure	1,5 × PN	15 min
External pressure differential (ISO 8533:2003, 7.2)	Negative pressure	– 0,8 bar (– 0,08 MPa)	1 h
Resistance to bending and pressure (ISO 8533:2003, 7.4)	Preliminary pressure	1,5 × PN	15 min
	Maintained pressure	1,5 × PN	24 h
Resistance to internal pressure (ISO 8533:2003, 7.5.1 to 7.5.6)	Maintained pressure	1,5 × PN	24 h
	Positive cyclic pressure	Atmospheric to 1,5 × PN and back to atmospheric	10 cycles of 1,5 min to 3,0 min each
Short-term resistance (ISO 8533:2003, 7.5.7 to 7.5.9)	Maintained pressure	3,0 × PN	6 min

NOTE 1 Nominal pressure (PN) is an alphanumeric designation of pressure related to the resistance of a component of a piping system to internal pressure.

NOTE 2 For joints intended to resist end-thrust loads, the above tests are performed with end loads applied to the joint. For non-end-load-bearing joints, the tests are performed without the end loads and the thrust is transferred to other sections of the test rig.

7.3.1.2 Performance requirements

7.3.1.2.1 Initial leakage test

When assembled in accordance with the pipe manufacturer's recommendations and subjected to a static-pressure test in accordance with ISO 8533, using a test pressure equal to 1,5 × PN bar, for 15 min, the joint shall remain leaktight and there shall be no visible damage to the joint components.

7.3.1.2.2 Leaktightness when subjected to an external pressure differential

When subjected to a negative-pressure test in accordance with ISO 8533, using a test pressure of – 0,8 bar (– 0,08 MPa), i.e. approximately 0,2 bar (0,02 MPa) absolute, for 1 h, the test piece shall not show any visible signs of damage to its components nor shall there be a change in pressure greater than 0,08 bar/h (0,008 MPa/h).

4) ISO 8533 has a transverse bending test with a specified bending load and support conditions, but some special installation conditions may require more severe loads and support conditions to be used. In countries where such special installation conditions are known to exist, the test loads and support conditions required shall be detailed in the national foreword.

7.3.1.2.3 Resistance to bending and pressure, including, if applicable, end thrust, for pipes up to and including DN 600

When subjected to a static pressure test in accordance with ISO 8533, using a test pressure equal to $1,5 \times PN$ bar, for 15 min, the joint shall remain leaktight and there shall be no visible damage to the joint components.

When subjected to a bending test in accordance with ISO 8533, using a test pressure equal to $1,5 \times PN$ bar, for 24 h, the joint shall remain leaktight and there shall be no visible damage to the joint components.

7.3.1.2.4 Resistance to internal pressure, including, if applicable, end thrust

When subjected to a static pressure test in accordance with ISO 8533, using a test pressure equal to $1,5 \times PN$ bar, for 24 h, the joint shall remain leaktight and there shall be no visible damage to the joint components.

When subjected to a positive cyclic pressure test in accordance with ISO 8533 of ten cycles, of 1,5 min to 3 min each, between atmospheric pressure and $1,5 \times PN$ bar, the joint shall remain leaktight and there shall be no visible damage to the joint components.

When subjected to a static pressure test in accordance with ISO 8533, using a test pressure equal to $3,0 \times PN$ bar, for 6 min, the joint shall remain leaktight and there shall be no visible damage to the joint components.

7.3.1.3 Number of test pieces for type testing

The number of joint assemblies to be tested for each test shall be one.

It is permissible for the same assembly to be used for more than one of the tests detailed in Table 25.

7.3.1.4 Test pieces

A test piece shall comprise a joint and two pieces of pipe such that the total laying length, L , is not less than the applicable value given in Table 15 or that which is necessary to meet the requirements of the test method.

7.3.2 Bolted flange joints

7.3.2.1 General

Bolted flange joints shall be tested for conformity to the requirements for performance under hydrostatic pressure detailed in 7.3.2.2 and Table 26, using test pieces conforming to 7.3.2.4. The methods of test are those given in ISO 8483⁵⁾, as appropriate, in conjunction with specific conditions dependent upon the nominal pressure (PN) for the piping system in which the particular type of joint is to be used. Specific values for PN are given in 4.1.4.

Table 26 — Summary of test requirements for bolted flange joints

Test	Pressure sequence	Test pressure bar	Duration
Initial leakage (ISO 8483:2003, 7.3)	Initial pressure	1,5 × PN	15 min
External pressure differential (ISO 8483:2003, 7.2)	Negative pressure	− 0,8 bar (− 0,08 MPa)	1 h
Resistance to internal pressure (ISO 8483:2003, 7.4)	Preliminary pressure	1,5 × PN	15 min
	Positive cyclic pressure	Atmospheric to 1,5 × PN and back to atmospheric	10 cycles of 1,5 min to 3,0 min each
	Maintained pressure	1,5 × PN	24 h
Resistance to bending (ISO 8483:2003, 7.5)	Preliminary pressure	1,5 × PN	15 min
	Maintained pressure	1,5 × PN	24 h
Short-term resistance (ISO 8483:2003, 7.6)	Maintained pressure	2,5 × PN for or	100 h
		3,0 × PN for	6 min
Bolt-tightening torque (ISO 8483:2003, 7.7)	Visual inspection	Not applicable	Not applicable

NOTE 1 Nominal pressure (PN) is an alphanumeric designation of pressure related to the resistance of a component of a piping system to internal pressure.

NOTE 2 For joints intended to resist end-thrust loads, the tests are performed with end loads applied to the joint. For non-end-load-bearing joints, the tests are performed without the end loads and the thrust is transferred to other sections of the test rig.

NOTE 3 For joints which are intended to be used with metallic flanges, the tests are performed in conjunction with a metallic flange. For joints which are intended to be used with GRP flanges, the tests are performed in conjunction with a GRP flange. For joints which are intended to be used with either metallic or GRP flanges, the tests are performed using both combinations.

For joints intended to be capable of resisting end loads, the tests shall be performed with the joint subject to the load from the end thrust. For joints not intended to be capable of resisting end loads, the tests shall be performed with the load from the end thrust carried by external supports.

If it is intended to connect the joint to a metallic flange, then the tests shall be performed with the joint so connected. If, however, it is intended to connect the joint to a GRP flange then the test shall be performed with the joint so connected. If it is intended to use the joint with either metallic or GRP flanges, then the joint shall be subjected to both conditions. Separate test pieces may be used for each series of tests.

5) ISO 8483 has a transverse bending test with a specified bending load and support conditions, but some special installation conditions may require more severe loads and support conditions to be used. In countries where such special installation conditions are known to exist, the test loads and support conditions required shall be detailed in the national foreword.

7.3.2.2 Performance requirements

7.3.2.2.1 Initial leakage test

When subjected to a static pressure test in accordance with ISO 8483, using a test pressure equal to $1,5 \times PN$ bar, for 15 min, the joint shall remain leaktight and there shall be no visible damage to the joint components.

7.3.2.2.2 Leaktightness when subjected to an external pressure differential

When subjected to a negative-pressure test in accordance with ISO 8483, using a test pressure of $-0,8$ bar ($-0,08$ MPa), i.e. approximately $0,2$ bar ($0,02$ MPa) absolute, for 1 h, the test piece shall not show any visible signs of damage to its components nor shall there be a change in pressure greater than $0,08$ bar/h ($0,008$ MPa/h).

7.3.2.2.3 Resistance to internal pressure, including, if applicable, end thrust

When subjected to a static pressure test in accordance with ISO 8483, using a test pressure equal to $1,5 \times PN$ bar, for 15 min, the joint shall remain leaktight and there shall be no visible damage to the joint components.

When subjected to a positive cyclic pressure test in accordance with ISO 8483 of ten cycles, of 1,5 min to 3 min each, between atmospheric pressure and $1,5 \times PN$ bar, the joint shall remain leaktight and there shall be no visible damage to the joint components.

When subjected to a static pressure test in accordance with ISO 8483, using a test pressure equal to $1,5 \times PN$ bar, for 24 h, the joint shall remain leaktight and there shall be no visible damage to the joint components.

7.3.2.2.4 Resistance to bending and pressure, including, if applicable, end thrust, for pipes up to and including DN 600

When subjected to a static pressure test in accordance with ISO 8483, using a test pressure equal to $1,5 \times PN$ bar, for 15 min, the joint shall remain leaktight and there shall be no visible damage to the joint components.

When subjected to a static bending test in accordance with ISO 8483, using a test pressure equal to $1,5 \times PN$ bar, for 24 h, the joint shall remain leaktight and there shall be no visible damage to the joint components.

7.3.2.2.5 Short-term resistance

When subjected to a static pressure test in accordance with ISO 8483, using a test pressure equal to $2,5 \times PN$ bar, for 100 h, the joint shall remain leaktight and there shall be no visible damage to the joint components. Alternatively, at the option of the manufacturer, the test may be performed with a test pressure equal to $3,0 \times PN$ bar, for 6 min, during which the joint shall remain leaktight and there shall be no visible damage to the joint components.

7.3.2.2.6 Resistance to bolt-tightening torque

When tested by the appropriate method described in ISO 8483, there shall be no visible damage to the joint components.

7.3.2.3 Number of test pieces for type testing

The number of joint assemblies to be tested for each test shall be one.

It is permissible for the same assembly to be used for more than one of the tests detailed in Table 26.

7.3.2.4 Test pieces

A test piece shall comprise a joint and two pieces of pipe such that the total laying length, L , is not less than the applicable value given in Table 15 or that which is necessary to meet the requirements of the test method.

7.3.2.5 Joint assembly details

The joint manufacturer shall supply full information on the flange, the gasket, the bolt torque, the degree and nature of the bolt lubrication, and the bolt-tightening sequence. These shall be fully complied with before commencing the tests detailed in ISO 8483.

Draft for comments only — Not to be cited as East African Standard

Annex A (normative)

Principles used to establish the design requirements based on regression testing and consideration of the variability of the product

A.1 General

The design procedure described in this annex has been used to formulate the minimum pressure performance requirements of this International Standard. This annex gives recommended minimum safety factors relative to product performance.

Like all plastics materials, GRP-UP is subject to creep under applied loads. GRP-UP pipe products are tested to establish the regression characteristics because these characteristics are influenced by the manufacturing method and the raw materials used.

This International Standard is based upon the principle that pipe products manufactured to a particular design, using a particular manufacturing process and particular materials, when tested in accordance with a specified regression test method, e.g. ISO 7509, will exhibit similar regression characteristics. Test data derived from this test is analysed using method A of ISO 10928:1997. The slope of the mean regression line derived from this analysis represents the general regression characteristics of products made from similar materials by similar processes.

The properties of GRP-UP products, like those of all manufactured materials, are recognized as having an inherent variability, but it is assumed that the manufacturing facility will be operating a quality control system which will enable the coefficient of variation (see 3.31) and AQL (see 3.32) to be determined for the initial circumferential tensile strength.

Clauses A.2 to A.7 summarize the design procedures appropriate for or applicable to the products.

A.2 Minimum safety factors for long-term pressure requirements

Most GRP pressure pipes are installed underground and are subjected to stress not only due to internal pressure, but also to ring bending resulting from soil and traffic loads. Consideration of these combined loadings and examination of the effects of varying the values of the probability of failure at 50 years has indicated that the safety factor for the combined loadings (η_{hat}) shall not be less than 1,5. Minimum ring deflection requirements are defined with respect to the pipe stiffness, which in effect defines the limits of the strain due to bending. Knowing the minimum acceptable value for η_{hat} and the bending conditions, the minimum acceptable value for the safety factor in tension η_t (see 3.44) is calculated. Using these concepts, the η_t values relating to the 97,5 % LCL and mean values have been calculated and are shown in Table A.1, which is a copy of Table 16.

Table A.1 — Minimum values of long-term safety factors η_t , PN, 97,5 % LCL and η_t , PN, mean

Pipe to which safety factor is to be applied	PN 32	PN 25	PN 16	PN 10	PN 6	PN 4	PN 2,5
Minimum safety factor, η_t , PN, 97,5 % LCL, to be applied to the long-term 97,5 % LCL	1,3	1,3	1,45	1,55	1,6	1,65	1,7
Minimum safety factor, η_t , PN, mean, to be applied to the long-term mean	1,6	1,6	1,8	1,9	2,0	2,05	2,1

The safety factors given in Table A.1 shall be used when the coefficient of variation, Y (see 3.31), for the initial failure pressure, p_0 , is 9 % or less. If the coefficient of variation is more than 9 %, then the applicable safety factor $(\eta_{t, PN, 97,5 \% LCL})_{new}$ or $(\eta_{t, PN, mean})_{new}$ shall be determined using either Equation (A.1) or (A.2), as applicable:

$$(\eta_{t, PN, 97,5 \% LCL})_{Table A.1} \times \frac{1 - 9 \times 0,01 \times 1,96}{1 - Y \times 0,01 \times 1,96} = (\eta_{t, PN, 97,5 \% LCL})_{new} \quad (A.1)$$

$$(\eta_{t, PN, mean})_{Table A.1} \times \frac{1 - 9 \times 0,01 \times 1,96}{1 - Y \times 0,01 \times 1,96} = (\eta_{t, PN, mean})_{new} \quad (A.2)$$

where

- $(\eta_{t, PN, 97,5 \% LCL})_{Table A.1}$ is the applicable safety factor given in Table A.1;
- $(\eta_{t, PN, 97,5 \% LCL})_{new}$ is the new applicable minimum safety factor;
- $(\eta_{t, PN, mean})_{Table A.1}$ is the applicable safety factor given in Table A.1;
- $(\eta_{t, PN, mean})_{new}$ is the new applicable minimum safety factor;
- Y is the coefficient of variation for the initial failure pressure, in percent.

A.3 Establishment of pressure regression ratio, $R_{R, p}$

Establish the regression characteristics of the pipes, using test pieces selected at random from pipes of the same pressure and stiffness class, for a series of initial failure tests and pressure regression tests. Use some of the test pieces for a long-term pressure regression test in accordance with ISO 7509 and some to determine the mean short-term failure pressure, $p_{0, mean}$ of the test sample in accordance with ISO 8521.

From the results of the long-term pressure test, determine a regression line using the method detailed in ISO 10928 (see Figure A.1). From projected values of this line at 0,1 h (6 min) and at 438 000 h (50 years), determine the p_6 and p_{50} failure pressure values.

Derive the value of the pressure regression ratio, $R_{R, p}$, for the products from Equation (A.3):

$$R_{R, p} = P_{50} / P_6 \quad (A.3)$$

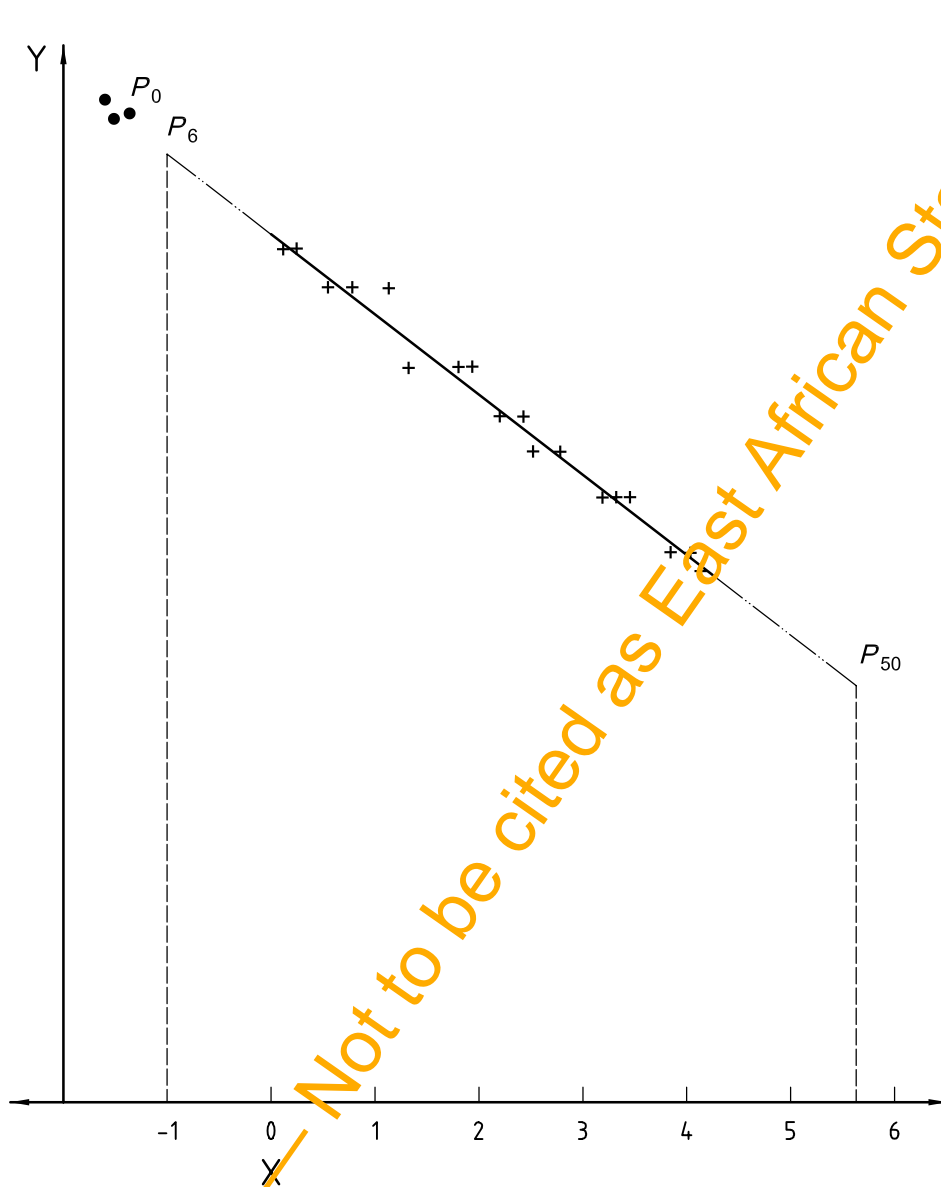

Key

- X log (time in hours)
- Y pressure
- + results from long-term pressure tests
- results from short-term pressure tests
- p_0 mean initial failure pressure
- p_6 projected failure pressure at 6 min
- p_{50} projected failure pressure at 50 years
- $R_{R,p}$ pressure regression ratio: $R_{R,p} = p_{50}/p_6$
- C correction factor for initial failure pressure: $C = p_0/p_6$

Figure A.1 — Derivation of pressure regression ratio, $R_{R,p}$

A.4 Determination of the design pressure value

A.4.1 Establishment of $p_{6, \min}$

NOTE The purpose of the long-term pressure test in relation to this design procedure is only to establish the regression characteristics. It should be noted that the long-term failure pressure value obtained from the test is only directly relevant to the pipes tested. If the projected long-term failure value does not satisfy the defined minimum long-term design requirements for the pressure class of the pipes tested, the regression characteristic can still be used for design purposes. However, in terms of validating the specific pressure class design of the pipes tested, it would show that the pipe as manufactured was inadequate.

Using the regression characteristics for the product, determined in accordance with Clause A.3, calculate the design pressure values for the various pipe classes as follows:

Using the required value of PN, determine the appropriate value of $\eta_{t, PN, 97,5\% \text{ LCL}}$ from Table A.1 or Equation (A.1), as applicable, then calculate the minimum failure pressure at 50 years, $p_{50, \min}$, using Equation (A.4), where the nominal pressure (PN) is expressed in bars. Calculate the minimum failure pressure at 6 min, $p_{6, \min}$, using the value of the regression ratio, $R_{R, p}$, derived from Equation (A.3) and the value of $p_{50, \min}$ from Equation (A.4) in Equation (A.5).

$$p_{50, \min} = \text{PN} \times \eta_{t, \text{PN}, 97,5\% \text{ LCL}} \quad (\text{A.4})$$

$$p_{6, \min} = \frac{\text{PN} \times \eta_{t, \text{PN}, 97,5\% \text{ LCL}}}{R_{R, p}} = \frac{p_{50, \min}}{R_{R, p}} \quad (\text{A.5})$$

A.4.2 Establishment of design pressure, $p_{0, d}$

NOTE Initial failure pressure test results are influenced by the rate of pressurization, and generally the higher the rate, the higher the failure pressure. To allow for this, the design procedure includes a correction factor, C , which is the ratio of the mean from the initial failure pressure tests performed as part of the regression test described in Clause A.3, p_0 , to the projected 6 min failure pressure, $p_{6, \min}$ [see Equation (A.6)].

Calculate the correction factor for initial failure, C , using Equation (A.6):

$$C = p_0 / p_{6, \min} \quad (\text{A.6})$$

Determine from Equation (A.7) the lower 97,5 % confidence limit of the initial failure pressure, $p_{0, \min}$, using $p_{6, \min}$ from Equation (A.5) and C from Equation (A.6):

$$p_{0, \min} = C \times p_{6, \min} \quad (\text{A.7})$$

Determine from Equation (A.8) the minimum design pressure, $p_{0, d}$, using $p_{0, \min}$ from Equation (A.7) and the coefficient of variation, Y , which is established from the quality system results obtained from the facility's routine product testing. A graphical representation of this procedure is given in Figure A.2 and a worked example is given in ISO 10328.

$$p_{0, d} = p_{0, \min} \times \frac{1}{(1 - Y \times 0,01 \times 1,96)} \quad (\text{A.8})$$

where

Y is the coefficient of variation, in percent, related to the mean initial failure pressure of the pipe manufactured at the facility (see 3.31);

1,96 is the multiplier for the 97,5 % confidence level.

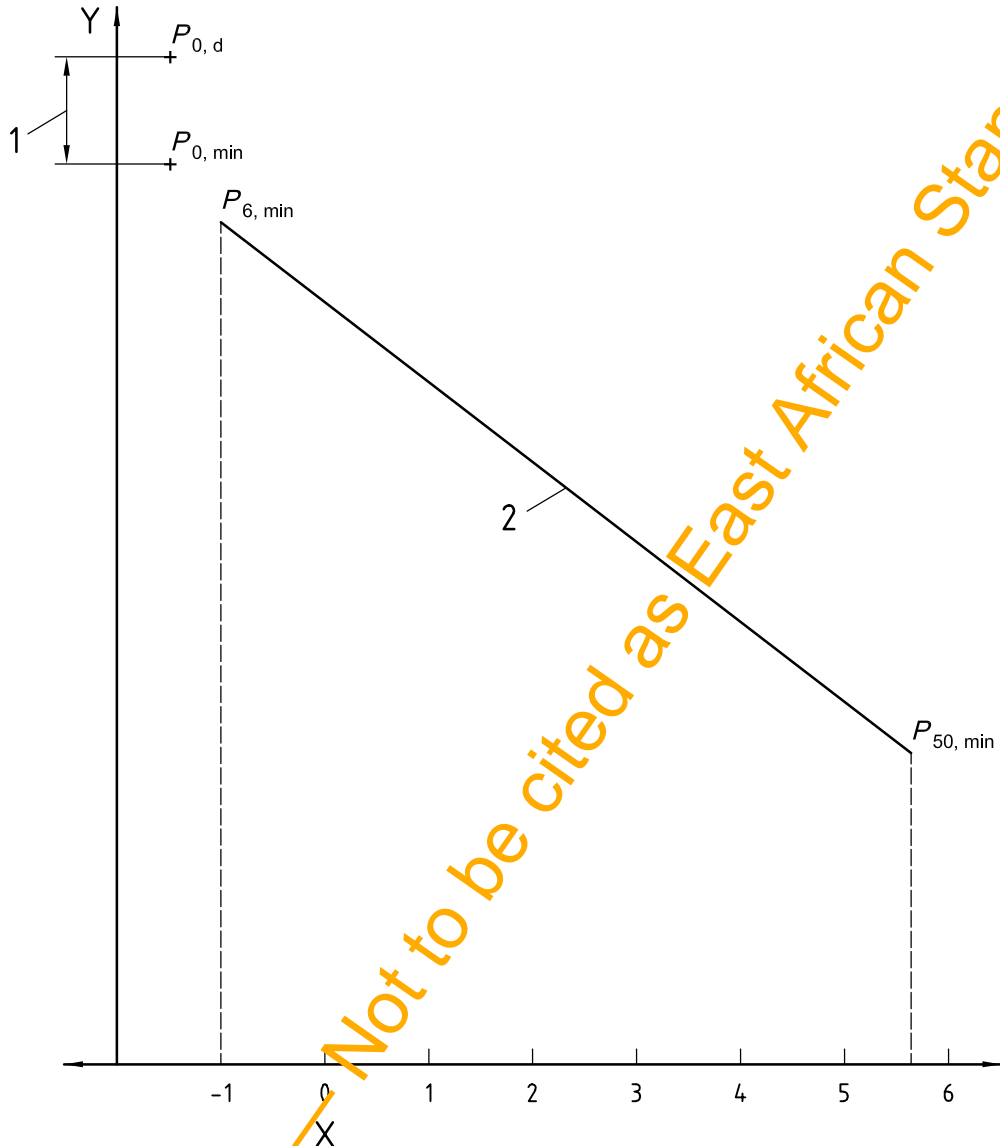

Key

- X log (time in hours)
- Y pressure
- 1 $1,96 \times \sigma$ (where σ is the standard deviation from the quality system)
- 2 97,5 % LCL

- $p_{0, d}$ minimum design initial failure pressure
- $p_{0, min}$ minimum initial failure pressure: $p_{0, min} = C \times p_{6, min}$
- $p_{6, min}$ minimum failure pressure at 6 min
- $p_{50, min}$ minimum failure pressure at 50 years
- C correction factor: $C = p_0/p_6$

The coefficient of variation, Y , is given by $Y = \sigma/\text{mean initial failure pressure } (p_{0, \text{mean}})$

Figure A.2 — Derivation of the minimum design initial failure pressure, $p_{0, d}$

A.4.3 Control procedures for $p_{0,d}$

To ensure that the safety factor related to the 97,5 % LCL at 50 years, $\eta_{t,PN,97,5\%LCL}$, and the safety factor, $\eta_{t,PN,mean}$, related to the minimum mean value at 50 years, $p_{50,mean,min}$, are met, perform the following procedures to determine the minimum design initial failure pressure, $p_{0,d}$ (see Figure A 3):

- a) Calculate the value of $p_{6,mean}$ using Equation (A.9):

$$\frac{p_{0,d}}{C} = p_{6,mean} \tag{A.9}$$

- b) Calculate the value of $p_{50,mean}$ using Equation (A.10):

$$p_{6,mean} \times R_{R,p} = p_{50,mean} \tag{A.10}$$

- c) Calculate the minimum value of $p_{50,mean}$ using Equation (A.11):

$$p_{50,mean,min} = PN \times \eta_{t,PN,mean} \tag{A.11}$$

where $\eta_{t,PN,mean}$ is the appropriate value from Table A.1 or, if applicable, calculated from Equation (A.2).

- d) If $p_{50,mean}$ from Equation (A.10) is equal to or greater than $p_{50,mean,min}$ from Equation (A.11), then $p_{0,d}$ is sufficient to satisfy the long-term safety factor relative to the mean. If it is not, then $p_{0,d}$ shall be increased until this requirement is satisfied. Satisfying this requirement also ensures that the safety factor related to the 97,5 % LCL at 50 years is also met, as $p_{50,mean,min}$ includes the value of $1,96 \times \sigma$.

A.5 Pressure product assessment

Using the results from initial failure tests performed over a period of time, determine the mean value, $p_{0,mean}$, and the standard deviation, σ , of the initial failure pressure. Calculate the coefficient of variation of this property, Y , in percent, using Equation (A.12):

$$Y = \frac{\text{Standard deviation} \times 100}{\text{Mean}} = \frac{\sigma}{p_{0,mean}} \tag{A.12}$$

To assess a product designed using the foregoing design method, the quality system is required to be able to confirm that the product passes the minimum pressure requirements and also needs to establish whether or not the average failure pressure of the product, $p_{0,mean}$, is equal to or greater than the minimum design value, $p_{0,d}$.

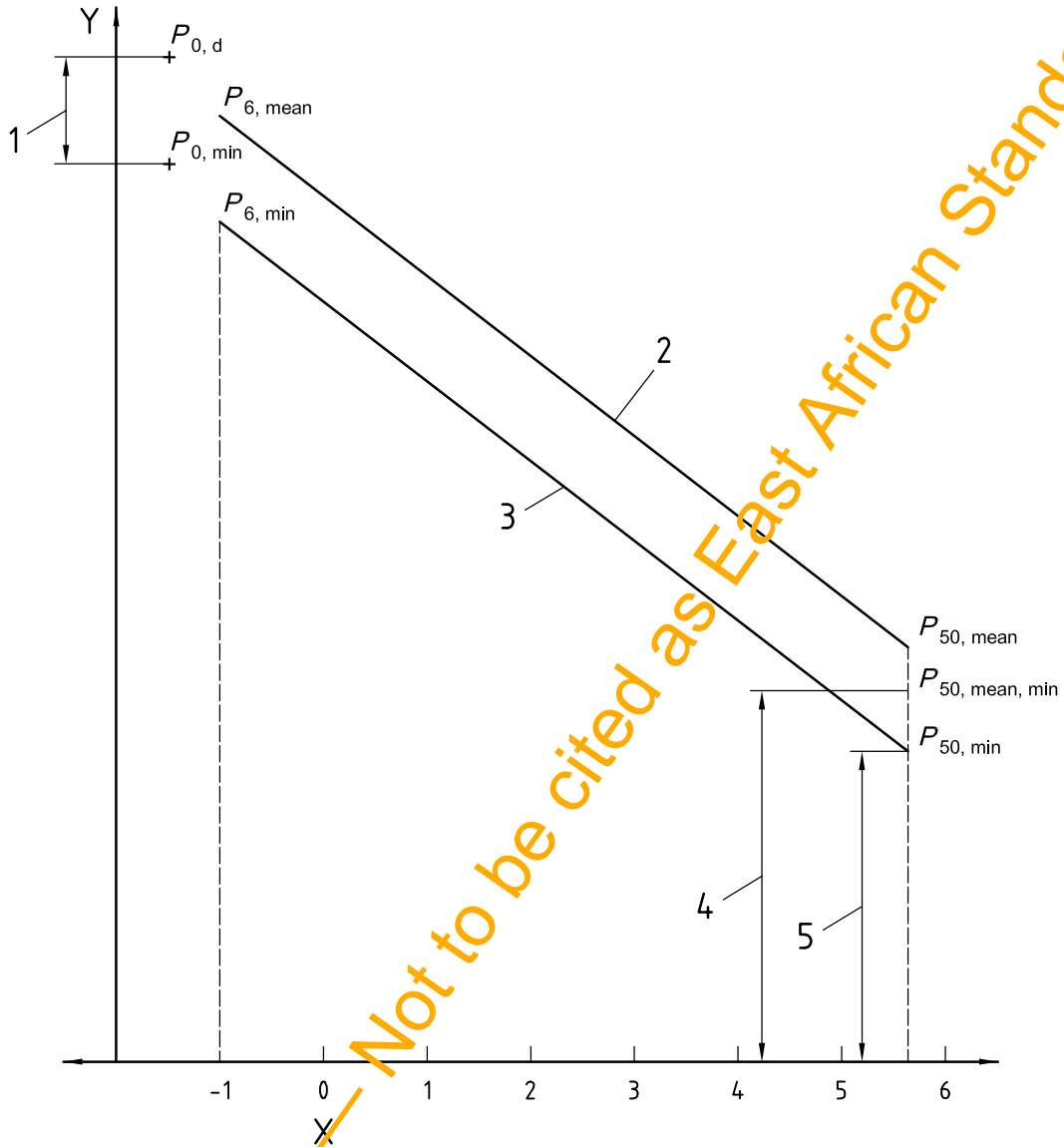

Key

- X log (time in hours)
- Y pressure
- 1 $1,96 \times \sigma$ (where σ is the standard deviation from the quality system)
- 2 mean line
- 3 97,5 % LCL line
- 4 $PN \times \eta_1 \times N$, mean
- 5 $PN \times \eta_2 \times 97,5 \%$ LCL
- $p_{0, d}$ minimum design initial failure pressure
- $p_{0, min}$ minimum initial failure pressure: $p_{0, min} = C \times p_{6, min}$
- $p_{6, min}$ minimum failure pressure at 6 min
- $p_{6, mean}$ mean failure pressure at 6 min
- $p_{50, min}$ minimum failure pressure at 50 years
- $p_{50, mean}$ mean failure pressure at 50 years
- $p_{50, mean, min}$ minimum mean failure pressure at 50 years
- C correction factor: $C = p_0/p_6$

Figure A.3 — Derivation of long-term mean failure pressures

A.6 Principles for the basis of ultimate deflection requirements

The minimum design flexural requirements specified in this International Standard when the pipe is subjected to ring bending are based upon values of the minimum ultimate long-term bending strain caused by long-term deflection. Although the bending capabilities of pipes vary depending on the method of manufacture and the materials used, the minimum initial and long-term ultimate ring deflection characteristics of pipes are specified relative to the nominal stiffness class (see 5.2.3.3.1 and Table 10). These deflections give approximately the same strain levels in all the various stiffness classes.

The deflection values given in Table 10 are based on the assumption that the maximum allowable long-term deflection when buried in the ground is 6 %. The manufacturer of the pipes may, however, specify a long-term deflection different to this assumed value. In such cases, the requirements given in Table 10 shall be adjusted proportionately, e.g. if the manufacturer's deflection value is 3 % then the required values would be 50 % of those given in Table 10 while a manufacturer's deflection value of 8 % would result in required values of 133 % of those given in Table 10.

A.7 Product assessment

The initial deflection tests used for product assessment require the test pieces to be deflected to values equivalent to the minimum long-term ultimate ring deflection under wet conditions without showing any signs of bore cracks and then deflected further to the relevant minimum value given in 5.2.3.3.2 without showing signs of structural damage.

Annex B (informative)

Guidance on leaktightness testing

B.1 General

There are different approaches to leaktightness testing. One concept is based on pressurizing the pipe to a low multiple of PN and inspecting for leakage. This is typically done on a significant number of the pipes produced using a pressure of $1,5 \times \text{PN}$. After being tested at this pressure, the pipes can still be installed in the works and hence the test is non-destructive.

A second concept is based on testing a small sample of the pipes produced at a high pressure. The test pressure is close to that used for the short-term ultimate pressure resistance of the product and the test piece is inspected for leakage. Due to the high pressure used, the test piece cannot subsequently be used in the works and the test is therefore a destructive test.

Each of these methods provides its own useful information but, because the methods are based on different pressures, they are not interchangeable. One or other of the methods may be more applicable to a particular product or manufacturing process, and the manufacturer selects the method they will use. For either method, the equipment required is substantial, so this is an additional reason why the manufacturer will only be equipped to perform one of the test procedures and also why the tests are limited to nominal sizes of DN 1400 or less.

Non-destructive test

This test is performed in accordance with method A of ISO 7511:1999, using a test pressure of $1,5 \times \text{PN}$ which is applied within 30 s and then maintained for the duration of the inspection period. To pass the test, the pipe has to be free of leaks.

Irrespective of whether the pipe is intended to be installed in a system that is subject to bi-axial loading, all pipes are tested so that they are only subject to uni-axial loading.

Destructive test

This test is performed in accordance with method A of ISO 7511:1999, using one of the following test pressures:

- a) Either $p_{x, \text{test, a}}$, equal to 75 % of the 97,5 % LCL line (see Figure B.1) for the selected test duration, x h. This pressure is maintained for the duration of the test period. The test piece is required not to leak. Frequently, after a test piece has passed this test, the test pressure is increased until the test piece fails. The pressure at failure is required to be at least $p_{x, \text{min}}$, derived from the 97,5 % LCL line for the selected test duration, x h. This pressure is equal to $p_{x, \text{test, b}}$ (see Figure B.1).
- b) Or $p_{x, \text{test, b}}$, equal to the pressure derived from the 97,5 % LCL line for the selected test duration, x h. This pressure is maintained for the duration of the test period. The test piece is required to complete the test without failure.

This procedure is illustrated in Figure B.1, which is an adaptation of Figure A.3.

NOTE The manufacturer selects the test duration in accordance with the procedures detailed in his quality manual and it can be as short as a few minutes or more than 24 h.

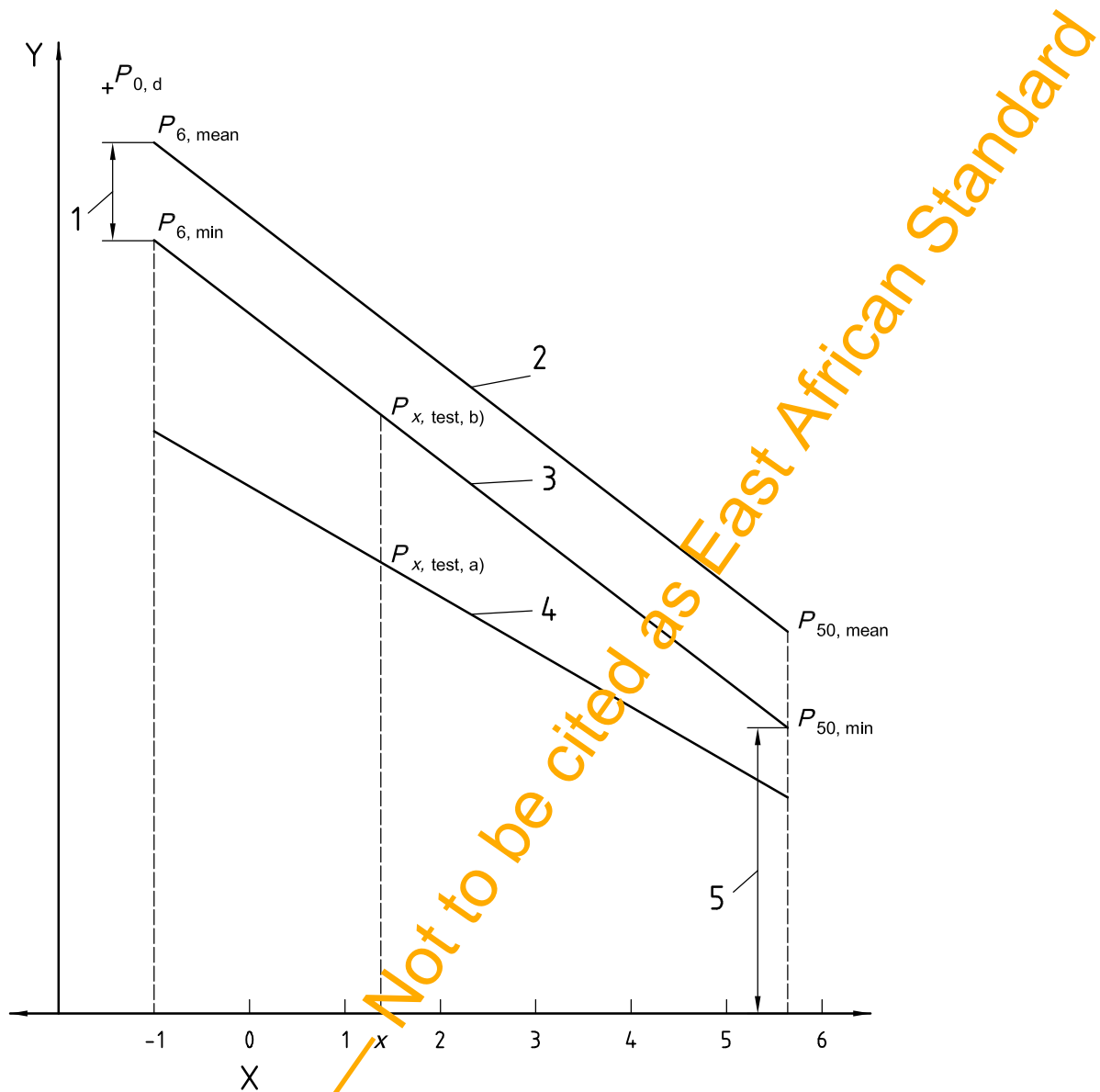

Key

- X log (time in hours)
- Y pressure
- 1 $1,96 \times \sigma$ (where σ is standard deviation from quality system)
- 2 mean line
- 3 97,5 % LCL line
- 4 leaktight line ($0,75 \times 97,5$ % LCL line)
- 5 $PN \times \eta_t, 97,5$ % LCL
- $p_{0,d}$ minimum design initial failure pressure
- $p_{6,min}$ minimum failure pressure at 6 min
- $p_{6,mean}$ mean failure pressure at 6 min
- $p_{x,test,a)}$ leaktightness test pressure for a)
- $p_{x,test,b)}$ test pressure and minimum failure pressure at x h, for b)
- $p_{50,min}$ minimum failure pressure at 50 years
- $p_{50,mean}$ mean failure pressure at 50 years

Figure B.1 — Derivation of test pressures for destructive leaktightness tests

Draft for comments only — Not to be cited as East African Standard

ICS 83.140.30; 91.140.60; 93.025

Price based on 72 pages

Draft for comments only — Not to be cited as East African Standard