



CD/K/061:2009
ICS 13.060.20; 71.100.80

EAST AFRICAN STANDARD

**Chemicals used for water intended for human consumption —
Chemicals for emergency use — Sodium dichloroisocyanurate,
dihydrate**

EAST AFRICAN COMMUNITY

Foreword

Development of the East African Standards has been necessitated by the need for harmonizing requirements governing quality of products and services in East Africa. It is envisaged that through harmonized standardization, trade barriers which are encountered when goods and services are exchanged within the Community will be removed.

In order to meet the above objectives, the EAC Partner States have enacted an East African Standardization, Quality Assurance, Metrology and Test Act, 2006 (EAC SQMT Act, 2006) to make provisions for ensuring standardization, quality assurance, metrology and testing of products produced or originating in a third country and traded in the Community in order to facilitate industrial development and trade as well as helping to protect the health and safety of society and the environment in the Community.

East African Standards are formulated in accordance with the procedures established by the East African Standards Committee. The East African Standards Committee is established under the provisions of Article 4 of the EAC SQMT Act, 2006. The Committee is composed of representatives of the National Standards Bodies in Partner States, together with the representatives from the private sectors and consumer organizations. Draft East African Standards are circulated to stakeholders through the National Standards Bodies in the Partner States. The comments received are discussed and incorporated before finalization of standards, in accordance with the procedures of the Community.

Article 15(1) of the EAC SQMT Act, 2006 provides that "Within six months of the declaration of an East African Standard, the Partner States shall adopt, without deviation from the approved text of the standard, the East African Standard as a national standard and withdraw any existing national standard with similar scope and purpose".

East African Standards are subject to review, to keep pace with technological advances. Users of the East African Standards are therefore expected to ensure that they always have the latest versions of the standards they are implementing.

© East African Community 2010 — All rights reserved*

East African Community

P O Box 1096

Arusha

Tanzania

Tel: 255 27 2504253/8

Fax: 255-27-2504481/2504255

E-Mail: eac@eachq.org

Web: www.each.int

Introduction

In the preparation of this East African Standard, the following source was consulted extensively:

BS EN 12932:2008, *Chemicals used for water intended for human consumption — Chemicals for emergency use — Sodium dichloroisocyanurate, dihydrate*

Assistance derived from this source and others inadvertently not mentioned is hereby acknowledged.

Draft for comments only — Not to be cited as East African Standard

**Chemicals used
for treatment of
water intended for
human consumption
— Chemicals
for emergency
use — Sodium
dichloroisocyanurate,
dihydrate**

ICS 13.060.20; 71.100.80

National foreword

This British Standard is the UK implementation of EN 12932:2008. It supersedes BS EN 12932:2000 which is withdrawn.

The UK participation in its preparation was entrusted to Technical Committee CII/59, Chemicals for drinking water treatment.

A list of organizations represented on this committee can be obtained on request to its secretary.

This publication does not purport to include all the necessary provisions of a contract. Users are responsible for its correct application.

Compliance with a British Standard cannot confer immunity from legal obligations.

This British Standard was published under the authority of the Standards Policy and Strategy Committee on 31 May 2009

© BSI 2009

ISBN 978 0 580 58053 6

Amendments/corrigenda issued since publication

Date	Comments

EUROPEAN STANDARD
 NORME EUROPÉENNE
 EUROPÄISCHE NORM

EN 12932

July 2008

ICS 71.100.80

Supersedes EN 12932:2000

English Version

**Chemicals used for treatment of water intended for human
 consumption - Chemicals for emergency use - Sodium
 dichloroisocyanurate, dihydrate**

Produits chimiques pour le traitement de l'eau destinée à la
 consommation humaine - Produits chimiques utilisés en
 cas d'urgence - Dichloroisocyanurate de sodium, dihydraté

Produkte zur Aufbereitung von Wasser für den
 menschlichen Gebrauch - Produkte für den Notfall -
 Natriumdichlorisocyanurat-dihydrat

This European Standard was approved by CEN on 28 June 2008.

CEN members are bound to comply with the CEN/CENELEC Internal Regulations which stipulate the conditions for giving this European Standard the status of a national standard without any alteration. Up-to-date lists and bibliographical references concerning such national standards may be obtained on application to the CEN Management Centre or to any CEN member.

This European Standard exists in three official versions (English, French, German). A version in any other language made by translation under the responsibility of a CEN member into its own language and notified to the CEN Management Centre has the same status as the official versions.

CEN members are the national standards bodies of Austria, Belgium, Bulgaria, Cyprus, Czech Republic, Denmark, Estonia, Finland, France, Germany, Greece, Hungary, Iceland, Ireland, Italy, Latvia, Lithuania, Luxembourg, Malta, Netherlands, Norway, Poland, Portugal, Romania, Slovakia, Slovenia, Spain, Sweden, Switzerland and United Kingdom.



EUROPEAN COMMITTEE FOR STANDARDIZATION
 COMITÉ EUROPÉEN DE NORMALISATION
 EUROPÄISCHES KOMITEE FÜR NORMUNG

Management Centre: rue de Stassart, 36 B-1050 Brussels

Contents

	Page
Foreword.....	3
Introduction.....	5
1 Scope	6
2 Normative references	6
3 Description	6
4 Purity criteria.....	8
5 Test methods.....	9
6 Labelling - Transportation - Storage.....	16
Annex A (informative) General information on sodium dichloroisocyanurate, dihydrate	19
Annex B (normative) General rules relating to safety.....	21
Annex C (normative) Determination of arsenic, antimony and selenium (atomic absorption spectrometry hydride technique).....	23
Bibliography	30

Foreword

This document (EN 12932:2008) has been prepared by Technical Committee CEN/TC 164 "Water supply", the secretariat of which is held by AFNOR.

This European Standard shall be given the status of a national standard, either by publication of an identical text or by endorsement, at the latest by January 2009, and conflicting national standards shall be withdrawn at the latest by January 2009.

Attention is drawn to the possibility that some of the elements of this document may be the subject of patent rights. CEN [and/or CENELEC] shall not be held responsible for identifying any or all such patent rights.

This document supersedes EN 12932:2000.

Significant technical difference between this edition and EN 12932:2000 is as follows:

— Deletion of reference to EU Directive 80/778/EEC of July 15, 1980 in order to take into account the latest Directive in force (see [1]).

Other amendments:

- a) section 3.1.2 – addition of "Troclosene sodium, dihydrate" as a synonym;
- b) section 4.3 – inclusion of the maximum admissible water content {14%};
- c) section 5.2:
 - 1) inclusion of section 5.2.2.1 Water;
 - 2) change numbering of following section to 5.2.2.2 Sodium chloride;
- d) section 6.1 – inclusion of big bags as permitted means of delivery;
- e) section 6.2 – updating of risk and safety labelling according to EU directives (Annex I of the Directive 67/548EEC and its latest Adaptations to Technical Progress);
 - 1) correction of hazard symbols {"N : Dangerous for the environment" instead of "O : Oxidizing"}
 - 2) addition of R phrase:
 - R 50/53: Very toxic to aquatic organisms, may cause long-term adverse effects in the aquatic environment.
 - 3) addition of S phrases:
 - S2: Keep out of the reach of children.
 - S 60: This material and its container must be disposed of as hazardous waste.
 - S 61: Avoid release to the environment. Refer to special instructions/safety data sheets.
- f) section 6.3 :

- 1) precision of the transport classification {"is not subject to the UN Model Regulations on the Transport of Dangerous goods" instead of "is not listed under a UN Number"};
- 2) change to note N° 5) {"United Nations Model Regulations on the Transport of dangerous goods, chapter 3.3.1, Special provision N°135" instead of "United Nations Number"};
- g) section 6.4 – addition of "Trosclosene sodium, dihydrate" as one possible chemical name.

According to the CEN/CENELEC Internal Regulations, the national standards organizations of the following countries are bound to implement this European Standard: Austria, Belgium, Bulgaria, Cyprus, Czech Republic, Denmark, Estonia, Finland, France, Germany, Greece, Hungary, Iceland, Ireland, Italy, Latvia, Lithuania, Luxembourg, Malta, Netherlands, Norway, Poland, Portugal, Romania, Slovakia, Slovenia, Spain, Sweden, Switzerland and the United Kingdom.

Introduction

In respect of potential adverse effects on the quality of water intended for human consumption, caused by the product covered by this European Standard:

- a) this European Standard provides no information as to whether the product may be used without restriction in any of the Member States of the EU or EFTA;
- b) it should be noted that, while awaiting the adoption of verifiable European criteria, existing national regulations concerning the use and/or the characteristics of this product remain in force.

NOTE Conformity with this European Standard does not confer or imply acceptance or approval of the product in any of the Member States of the EU or EFTA. The use of the product covered by this European Standard is subject to regulation or control by National Authorities.

1 Scope

This European Standard is applicable to sodium dichloroisocyanurate dihydrate used for emergency treatment of water intended for human consumption. It describes the characteristics of sodium dichloroisocyanurate dihydrate and specifies the requirements and the corresponding test methods for sodium dichloroisocyanurate dihydrate. It gives information on its use in water treatment. It also determines the rules relating to safe handling and use of sodium dichloroisocyanurate dihydrate (see Annex B).

2 Normative references

The following referenced documents are indispensable for the application of this document. For dated references, only the edition cited applies. For undated references, the latest edition of the referenced document (including any amendments) applies.

EN 1233, *Water quality - Determination of chromium - Atomic absorption spectrometric methods*

EN 1483, *Water quality - Determination of mercury – Method using atomic absorption spectrometry*

EN ISO 3696, *Water for analytical laboratory use - Specification and test methods (ISO 3696:1987)*

ISO 3165, *Sampling of chemical products for industrial use - Safety in sampling*

ISO 6206, *Chemical products for industrial use - Sampling – Vocabulary*

ISO 8213, *Chemical products for industrial use - Sampling techniques - Solid chemical products in the form of particles varying from powders to coarse lumps*

ISO 8288:1986, *Water quality - Determination of cobalt, nickel, copper, zinc, cadmium and lead - Flame atomic absorption spectrometric methods*

3 Description

3.1 Identification

3.1.1 Chemical name

1-sodium, 3, 5-dichloro-1,3,5-triazine-2, 4, 6-trione dihydrate.

3.1.2 Synonym or common name

Sodium dichloroisocyanurate, dihydrate.

Troclosene sodium, dihydrate

3.1.3 Relative molecular mass

256,02

3.1.4 Empirical formula

$C_3N_3O_3Cl_2Na \cdot 2H_2O$

3.1.5 Chemical formula

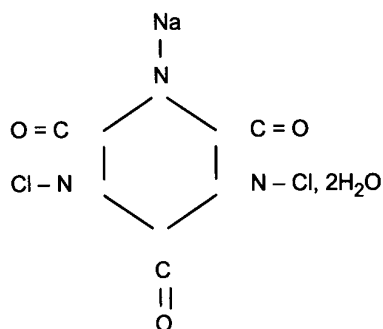

3.1.6 CAS Registry Number ¹⁾

51580-86-0

3.1.7 EINECS reference ²⁾

Not listed.

3.2 Commercial form

The product is available in various granular forms.

3.3 Physical properties

3.3.1 Appearance and odour

The product is a white granular solid with chlorinous odour.

3.3.2 Density

The bulk density of the product is approximately 0,9 g/cm³.

3.3.3 Solubility in water

The solubility of the product in water is 291 g/l at 25 °C.

3.3.4 Vapour pressure

Not applicable.

3.3.5 Boiling point at 100 kPa ³⁾

Not applicable, the product decomposes before fusion.

1) Chemical Abstracts Service Registry Number.

2) European Inventory of Existing Commercial Chemical Substances.

3) 100 kPa = 1 bar

BS EN 12932:2008
EN 12932:2008 (E)

3.3.6 Melting point

Not applicable.

3.3.7 Specific heat

(1,090 ± 0,040) kJ/kg.K at 20 °C.

3.3.8 Viscosity

Not applicable.

3.3.9 Critical temperature

Not applicable.

3.3.10 Critical pressure

Not applicable.

3.3.11 Physical hardness

Not applicable.

3.4 Chemical properties

The product is a strong oxidant. It liberates chlorine by hydrolysis.

4 Purity criteria

4.1 General

This European Standard specifies the minimum purity requirements for dihydrate sodium dichloroisocyanurate used for the treatment of water intended for human consumption. Limits are given for impurities commonly present in the product. Depending on the raw material and the manufacturing process other impurities may be present and, if so, this shall be notified to the user and when necessary to the relevant authorities.

NOTE Users of this product should check the national regulations in order to clarify whether it is of appropriate purity for treatment of water intended for human consumption, taking into account raw water quality, required dosage, contents of other impurities and additives used in the product not stated in this product standard.

Limits have been given for impurities and chemical parameters where these are likely to be present in significant quantities from the current production process and raw materials. If the production process or raw materials lead to significant quantities of impurities, by-products or additives being present, this shall be notified to the user.

4.2 Composition of commercial product

The product shall contain at least a mass fraction of 55 % of available chlorine as calculated in accordance with the corresponding method given in 5.2.1.

4.3 Impurities and main by-products

The water content shall be less than a mass fraction of 14 % of the product.

The sodium chloride content shall be less than a mass fraction of 0,05 % of the product.

4.4 Chemical parameters

The product shall conform to the requirements specified in Table 1.

Table 1 – Chemical parameters

Element		Limit mg/kg of product	
		Type 1	Type 2
Arsenic (As)	max.	10	10
Cadmium (Cd)	max.	1	1
Chromium (Cr)	max.	6	10
Mercury (Hg)	max.	0,02	0,02
Nickel (Ni)	max.	3	3
Lead (Pb)	max.	4	4
Antimony (Sb)	max.	5	5
Selenium (Se)	max.	1	1

NOTE Cyanide, which does not exist in a strong oxidizing medium such as sodium dichloroisocyanurate, dihydrate, is not a relevant chemical parameter. Pesticides and polycyclic aromatic hydrocarbons are not by-products of the manufacturing process. For parametric values of sodium dichloroisocyanurate on trace metal content in drinking water, see [1].

5 Test methods

5.1 Sampling

Observe the general recommendations of ISO 3165 and take account of ISO 6206. Prepare the laboratory sample(s) required by the relevant procedure described in ISO 8213.

5.2 Analysis

5.2.1 Determination of available chlorine (main product)

5.2.1.1 Principle

The available chlorine is determined by measuring active chlorine in the sample. The oxidizing chlorine reacts with potassium iodide releasing iodine which is then titrated with sodium thiosulfate standard volumetric solution in the presence of starch indicator solution.

5.2.1.2 Reagents

All reagents shall be of a recognized analytical grade and the water used shall conform to grade 3 in accordance with EN ISO 3696.

5.2.1.2.1 Potassium iodide crystals (KI).

5.2.1.2.2 Glacial acetic acid.

5.2.1.2.3 Sodium thiosulfate standard volumetric solution, $c(\text{Na}_2\text{S}_2\text{O}_3 \cdot 5\text{H}_2\text{O}) = 0,1 \text{ mol/l}$.

Standard volumetric solutions of sodium thiosulfate are commercially available.

Alternatively a standard volumetric solution can be prepared by the following procedure:
Dissolve 24,8 g $\text{Na}_2\text{S}_2\text{O}_3 \cdot 5 \text{H}_2\text{O}$ in a 1 000 ml one-mark volumetric flask in about 0,75 l water. After the temperature has equalized make up to the mark with water and mix thoroughly.

To standardize :

Weigh, to the nearest 0,1 mg, 3,600 g (m) of dry potassium iodate. Dissolve in water in a 1 000 ml one-mark volumetric flask, make up to the mark with water and mix (standard reference solution $c(1/6 \text{ KIO}_3) = 0,1 \text{ mol/l}$). Place 200 ml of water in a 500 ml stoppered conical flask, add $(2 \pm 0,5)$ g of potassium iodide and stir to dissolve. Then introduce, by means of a pipette, 10,0 ml of sodium thiosulfate solution for standardization, add (15 ± 1) ml of hydrochloric acid solution (diluted 1 + 1 by volume) and (5 ± 1) ml of starch solution (5.2.1.2.4). Titrate immediately with the potassium iodate standard reference solution until the appearance of a blue coloration persisting for at least 30 s occurs. Record the volume (V_1) of iodate used.

The actual concentration, c , of the sodium thiosulfate standard volumetric solution ($\text{Na}_2\text{S}_2\text{O}_3 \cdot 5\text{H}_2\text{O}$), expressed in moles per litre is given by the following equation:

$$c = \frac{V_1 \times c_1}{V} \quad (1)$$

where

c_1 is the concentration, expressed in moles per litre, of the potassium iodate standard reference solution [$c(1/6 \text{ KIO}_3) = 0,1 \text{ mol/l}$];

V is the volume, in millilitres, of the sodium thiosulfate standard volumetric solution used for the standardization ($V = 10 \text{ ml}$);

V_1 is the volume, in millilitres, of potassium iodate standard reference solution used in the titration.

5.2.1.2.4 Starch solution, mass fraction 1 % .

Make a slurry with $(1 \pm 0,1)$ g starch and (5 ± 1) ml water. Add (90 ± 5) ml boiling water to the slurry. Stir to dissolve it and cool the solution. This solution needs refrigeration to avoid the decomposition of the starch which results in a vague end point. Keep the solution cool and use it within one week.

NOTE Commercial indicators for iodine titration exist and can be used in place of the specified starch solution provided that their efficiency has been previously tested.

5.2.1.3 Apparatus

5.2.1.3.1 Ordinary laboratory apparatus and glassware.

5.2.1.4 Procedure

5.2.1.4.1 Test portion

Weigh, to the nearest 0,1 mg, 0,25 g of the laboratory sample (m_0) into a tared stoppered weighing bottle.

5.2.1.4.2 Determination

Transfer the test portion to a 200 ml volumetric flask.

Add 10 ml of water and 10 ml of glacial acetic acid (5.2.1.2.2), stir for 5 min and then add 100 ml of water and 2 g of potassium iodide (5.2.1.2.1), and mix to dissolve and wait 10 min. Titrate with the sodium thiosulfate standard volumetric solution (5.2.1.2.3) to a light yellow colour. Add 5 ml of the starch solution (5.2.1.2.4) and continue titration to the disappearance of the blue black colour. Record the volume (V_1) of the sodium thiosulfate standard volumetric solution used.

5.2.1.5 Expression of results

The chlorine (Cl_2) content, C_1 , expressed as a mass fraction in %, is given by the following equation:

$$C_1 = \frac{V_1 \times 0,003545 \times c}{m_0} \times 100 \quad (2)$$

where

V_1 is the volume, in millilitres, of the sodium thiosulfate standard volumetric solution (5.2.1.2.3) used for the titration;

m_0 is the mass, in grams, of the test portion (5.2.1.4.1);

0,003545 is the mass, in grams, of chlorine (Cl_2) corresponding to 1,00 ml of sodium thiosulfate solution, $c(\text{Na}_2\text{S}_2\text{O}_3 \cdot 5\text{H}_2\text{O}) = 0,1 \text{ mol/l}$;

c is the actual concentration, expressed in moles per litre, of the sodium thiosulfate standard volumetric solution (5.2.1.2.3).

5.2.1.6 Accuracy

The result is accurate to within $\pm 0,1 \%$.

5.2.2 Impurities

5.2.2.1 Water

5.2.2.1.1 Principle

The water content in sodium dichloroisocyanurate is determined by the mass loss after heating in an oven. The temperature is set at a low level because sodium dichloroisocyanurate can lose chlorine on heating.

5.2.2.1.2 Apparatus

5.2.2.1.2.1 Oven made of aluminium, provided with a means of circulating the air inside.

5.2.2.1.3 Procedure

Weigh 10 g of the laboratory sample (m_1), to the nearest 0,001g, in a glass evaporating dish (diameter 150 mm).

Put it in the ventilated oven at 105 °C for 4 h.

Allow to cool in a desiccator and weigh again.

5.2.2.1.4 Expression of results

The water content (w), expressed as a mass fraction in % is given by the following equation:

$$w = \left(\frac{m_1 - m_2}{m_1} \right) \times 100 \quad (3)$$

where

m_1 is the mass, in grams, before drying;

m_2 is the mass, in grams, after drying.

5.2.2.2 Sodium chloride

5.2.2.2.1 General

This method applies to products with sodium chloride content in the range of a mass fraction from 0 % to 0,05 %.

5.2.2.2.2 Principle

The sodium dichloroisocyanurate dihydrate is acidified and then digested to remove all traces of available chlorine. Sodium is analysed in solution by atomic absorption spectrometry.

5.2.2.2.3 Reagents

All reagents shall be of a recognized analytical grade and the water used shall conform to grade 3 in accordance with EN ISO 3696.

5.2.2.2.3.1 Sulfuric acid concentrated, (H_2SO_4) mass fraction 95 % minimum.

5.2.2.2.3.2 Sodium standard stock solution, $c(\text{Na}) = 1\,000\ \mu\text{g/ml}$.

Weigh 2,542 1 g of sodium chloride that has been previously dried for 1 h at 110 °C. Dissolve with water and make up to the mark with water in a 1 000 ml one mark volumetric flask. Mix well.

5.2.2.2.4 Apparatus

Ordinary laboratory apparatus and glassware, together with the following:

5.2.2.2.4.1 Atomic absorption spectrometer equipped with sodium hollow cathode lamp;

5.2.2.2.4.2 Hot plates.

5.2.2.2.5 Procedure

5.2.2.2.5.1 Test portion

Weigh, to the nearest 0,1 mg, 2,5 g of the laboratory sample (m_3) into a tared stoppered weighing bottle.

5.2.2.2.5.2 Determination

Transfer the test portion to a 250 ml beaker. Dilute with 25 ml of water.

Mix and then add 10 ml of the concentrated sulfuric acid (5.2.2.2.3.1) and place on a hot plate (5.2.2.2.4.2) and boil until the salt begins to precipitate. Rinse the inside of the beaker with water.

Transfer to a 250 ml volumetric flask and make up to the mark with water and mix well.

Measure the absorbance of the solution on the atomic absorption spectrometer (5.2.2.2.4.1) with sodium hollow cathode lamp at a wavelength of 330,2 nm with slit setting at "4" using an air-acetylene flame.

5.2.2.2.5.3 Calibration

Transfer accurately from the sodium standard solutions (5.2.2.2.3.2) 1,0 ml, 2,0 ml, 3,0 ml, 4,0 ml, 5,0 ml, and 10,0 ml portions to a series of 100 ml volumetric flasks, make up each to the mark with water and mix well. Prepare a calibration blank.

Measure the absorbance of each calibration solution as described in 5.2.2.2.5.2, and prepare a calibration graph.

5.2.2.2.6 Expression of results

The sodium chloride content, (C_2), expressed as a mass fraction in % of product is given by the following equation :

$$C_2 = \frac{c \times 100 \times 20 \times 2,5421}{m_3 \times 10000} \quad (4)$$

where

m_3 is the mass, in grams, of the test portion;

c is the concentration, in micrograms per millilitre, of sodium in the test portion as determined from the calibration graph.

5.2.2.2.7 Repeatability limit

The absolute difference between two single test results, obtained under repeatability conditions, shall not be greater than the repeatability value, r , as calculated from the following equation:

$$r = 0,025 z \quad (5)$$

where

z is the mean of the two results, expressed in mass fraction in %.

NOTE 1 A 98,3 % to 100,7 % recovery was obtained at Na content of mass fraction of 20 % .

NOTE 2 Repeatability conditions are conditions where mutually independent test results are obtained with the same method on identical test material in the same laboratory by the same operator using the same equipment within short intervals of time.

BS EN 12932:2008
EN 12932:2008 (E)

5.2.3 Chemical parameters

5.2.3.1 Determination of antimony (Sb), arsenic (As), cadmium (Cd), chromium (Cr), lead (Pb), nickel (Ni) and selenium (Se)

5.2.3.1.1 Principle

The elements arsenic, antimony, cadmium, chromium, lead, nickel and selenium are determined by atomic absorption spectrometry.

5.2.3.1.2 Reagents

5.2.3.1.2.1 General

All reagents shall be of a recognized analytical grade and the water used shall conform to the grade 3 specified in EN ISO 3696.

5.2.3.1.2.2 Nitric acid, concentrated, density $\rho = 1,42$ g/ml.

5.2.3.1.3 Procedure

5.2.3.1.3.1 Test portion

Weigh, to the nearest 0,01 g, 20 g (m_4) of the laboratory sample into a 100 ml one mark volumetric flask.

5.2.3.1.3.2 Test solution

Add 1 ml of nitric acid (5.2.3.1.2.2) to the test portion, dilute with a few millilitres of water and mix. Dilute to volume with water and homogenize.

5.2.3.1.3.3 Determination

Determine the content of chemical parameters in the test solution (5.2.3.1.3.2) in accordance with the following methods:

Cd, Ni and Pb : in accordance with ISO 8288:1986, Method A;

Cr : in accordance with EN 1233;

As, Se and Sb : in accordance with the method given in Annex C.

These methods provide an interim result (y) expressed in milligrams per litre which needs to be converted to give the final concentration according to the equation in 5.2.3.1.4.

5.2.3.1.4 Expression of results

From the interim result (y) determined (see 5.2.3.1.3.3), the content, C_3 , of each chemical parameter in the laboratory sample expressed in milligrams per kilogram of product is given by the following general equation:

$$C_3 = y \times \frac{V}{m_4} \times \frac{100}{C_1} \quad (6)$$

where

- y is the interim result (5.2.3.1.3.3);
- V is the volume, expressed in millilitres, of the test solution (5.2.3.1.3.2) (= 100 ml);
- m_4 is the mass, expressed in grams, of the test portion;
- C_1 is the available chlorine content in mass fraction of product (see 5.2.1.5).

5.2.3.2 Determination of the mercury content (Hg)

5.2.3.2.1 Principle

The element mercury is determined by flameless atomic absorption spectrometry in accordance with EN 1483.

5.2.3.2.2 Reagents

All reagents shall be of a recognized analytical grade and the water used shall conform to the grade 3 specified in EN ISO 3696.

5.2.3.2.2.1 Potassium permanganate solution, $c(\text{KMnO}_4) = 50 \text{ g/l}$.

5.2.3.2.2.2 Sulfuric acid, concentrated, density $\rho = 1,84 \text{ g/ml}$.

5.2.3.2.2.3 Hydroxylammonium chloride, solution, $c(\text{NH}_2\text{OH}\cdot\text{HCl}) = 100 \text{ g/l}$.

5.2.3.2.2.4 Potassium dichromate solution, $c(\text{K}_2\text{Cr}_2\text{O}_7) = 4 \text{ g/l}$ in volume fraction 50 % nitric acid solution.

5.2.3.2.3 Procedure

5.2.3.2.3.1 Test portion

Weigh, to the nearest 0,01 g, 10 g (m_5) of the laboratory sample into a glass beaker.

5.2.3.2.3.2 Test solution

Quantitatively transfer the test portion to 100 ml (V_1) volumetric flask. Make up to the mark with water (solution A).

Pipette 10 ml of the solution A. Transfer into a 250 ml conical flask, add 60 ml of water, 20 ml of a potassium permanganate solution (5.2.3.2.2.1) and five 1 ml portions of sulfuric acid (5.2.3.2.2.2). Bring to the boil and maintain boiling for 10 min. Allow to cool. Dissolve the precipitate (MnO_2) with hydroxylammonium chloride (5.2.3.2.2.3), add 5 ml of the potassium dichromate solution (5.2.3.2.2.4) and transfer into a 100 ml (V_2) volumetric flask. Make up to the mark with water and mix.

5.2.3.2.3.3 Determination

Proceed as described in EN 1483.

5.2.3.2.3.4 Expression of results

The interim result for mercury content (y) expressed in milligrams per litre is given by the following equation:

$$y = y_A \times \frac{V_2}{10} \tag{7}$$

where

y_A is the result obtained in 5.2.3.2.3.3, for the concentration of mercury in the test solution, expressed in milligrams per litre;

V_2 is the volume in millilitres of the test solution.

The mercury content, C_4 , in milligrams per kilogram of product is given by the following equation:

$$C_4 = y \cdot \frac{V_1}{m_5} \times \frac{100}{C_1} \tag{8}$$

where

y is the interim result for mercury content;

m_5 is the mass, expressed in grams, of the test portion (5.2.3.2.3.1);

C_1 is the available chlorine content in mass fraction (see 5.2.1.5);

V_1 is the volume in millilitres of the solution A (see 5.2.3.2.3.2).

6 Labelling - Transportation - Storage

6.1 Means of delivery

The product shall be delivered in fibre or polyethylene drums, big bags or in semi-bulk containers.

In order that the purity of the product is not affected, the means of delivery shall not have been used previously for any different product or it shall have been specially cleaned and prepared before use.

6.2 Risk and safety labelling according to the EU directives ⁴⁾

The following labelling requirements shall apply to sodium dichloroisocyanurate, dehydrate at the date of publication of this European standard:

a) Symbols and indications of danger:

- 1) Xn : Harmful;
- 2) N : Dangerous for the environment.

b) Nature of special risks attributed to dangerous substances:

4) See [2].

- 1) R 22 : Harmful if swallowed;
 - 2) R 31 : Contact with acids liberates toxic gas;
 - 3) R 36/37 : Irritating to eyes and respiratory system;
 - 4) R 50/53 : Very toxic to aquatic organisms, may cause long-term adverse effects in the aquatic environment.
- c) Safety advice concerning dangerous substances:
- 1) S 2 : Keep out of the reach of children;
 - 2) S 8 : Keep container dry;
 - 3) S 26 : In case of contact with eyes, rinse immediately with plenty of water and seek medical advice;
 - 4) S 41 : In case of fire and/or explosion do not breathe fumes;
 - 5) S 60 : This material and its container must be disposed of as hazardous waste;
 - 6) S 61 : Avoid release to the environment. Refer to special instructions/safety data sheets.

NOTE Annex I of the Directive 67/548/EEC on Classification, packaging and labelling of dangerous substances and its amendments and adaptations in the European Union contains a list of substances classified by the EU. Substances not in this Annex I should be classified on the basis of their intrinsic properties according to the criteria in the Directive by the person responsible for the marketing of the substance.

6.3 Transportation regulations and labelling

Sodium dichloroisocyanurate, dihydrate is not subject to the UN Model Regulations on the transport of dangerous goods⁵⁾. It is not classified as a dangerous product for road, rail, sea and air transportation.

6.4 Marking

The marking shall include the following:

- the name "sodium dichloroisocyanurate, dihydrate" or "Trosclosene sodium, dihydrate", trade name, grade and type;
- the net mass;
- the name and the address of supplier and/or manufacturer;
- the statement "This product conforms to EN 12932".

6.5 Storage

The product shall be stored in original packages firmly closed in a cool and dry place, away from any sources of heat or incompatible materials.

6.5.1 Long term stability

When stored in appropriate conditions, the product is stable for at least three years.

5) United Nations Model Regulations on the transport of dangerous goods, chapter 3.3.1, Special provision N°135

BS EN 12932:2008
EN 12932:2008 (E)

6.5.2 Storage incompatibilities

Store preferably alone, keep away from:

- water, moisture;
- nitrogenated products;
- organic solvents;
- hydrocarbons;
- peroxides;
- hypochlorites;
- oils, greases and organic materials;
- ammonium salts;
- basic products.

Annex A (informative)

General information on sodium dichloroisocyanurate, dihydrate

A.1 Origin

A.1.1 Raw materials

Sodium dichloroisocyanurate dihydrate is manufactured from isocyanuric acid (CNOH)₃, sodium hydroxide (NaOH) and chlorine (Cl₂).

A.1.2 Manufacturing process

Sodium dichloroisocyanurate is produced by chlorination of disodium cyanurate (Na₂H(NCO)₃) using chlorine (Cl₂) and neutralization with sodium hydroxide (NaOH).

Disodium cyanurate is obtained by action of sodium hydroxide on isocyanuric acid.

A.2 Use

A.2.1 Function

The product is a water treatment chemical for emergency use, used as disinfectant by generation of hypochlorous acid through hydrolysis:



A.2.2 Form in which it is used

The product is used in solution up to approximately at mass fraction of 1 % in water.

A.2.3 Treatment dose

Subject to local regulations, depending on the quality of the water to be treated, usually the concentration of active chlorine should not exceed a few tenths of mg/l.

A.2.4 Mean of application

Pre-dissolution and automatic feeding using metering pumps.

BS EN 12932:2008
EN 12932:2008 (E)

A.2.5 Secondary effects

The secondary effects include the following:

- oxidation of iron, of manganese and ammonium compounds;
- slight increase of "Kjeldahl" nitrogen;
- slight increase in the chloride content;
- odour and colour removal;
- oxidation of organic compounds.

A.2.6 Removal of excess product

Removal by using an aqueous solution of sodium sulfite or sodium hydrogensulfite. Passing through activated carbon is also effective.

Annex B (normative)

General rules relating to safety

B.1 Rules for safe handling and use

The supplier shall provide current safety instructions.

B.2 Emergency procedures

B.2.1 First aid

- a) In case of contact with skin:
 - 1) remove the product in excess;
 - 2) rinse immediately with cold water for 25 min;
 - 3) remove the contaminated clothes.
- b) In case of contact with eyes:
 - 1) rinse immediately with cold water for about 30 min;
 - 2) seek medical advice immediately.
- c) In case of inhalation:
 - 1) place the affected person at rest away from the polluted area;
 - 2) place in reclining position;
 - 3) seek medical advice immediately.
- d) In case of ingestion:
 - 1) gently clean the mouth with a clean linen;
 - 2) give large quantity of water to drink if the person is conscious;
 - 3) place the person in a safe position in case of loss of consciousness;
 - 4) seek medical advice immediately.

BS EN 12932:2008
EN 12932:2008 (E)

B.2.2 Spillage

Collect and store in separate containers. Do not accumulate the spilled material, and do not dispose of it via a rubbish bin or drains. Disposal shall be carried out in accordance with the local regulations.

B.2.3 Fire

The material is not combustible, but due to the formation of oxygen as decomposition by-product it will support combustion. Use air-independent respiratory equipment for fire fighting. Use water to extinguish fire and to cool containers exposed to fire. Do not use dry chemical extinguishers containing ammonium compounds, e.g. monoammonium phosphate.

Annex C (normative)

Determination of arsenic, antimony and selenium (atomic absorption spectrometry hydride technique)

SAFETY PRECAUTIONS: Arsenic, antimony and selenium and their hydrides are toxic. Handle with care.

C.1 General principle

Arsenious acid, antimonous acid and selenious acid, the As(III), Sb(III) and Se(IV) oxidation states of arsenic, antimony and selenium, respectively, are instantaneously converted by sodium borohydride reagent in acid solution to their volatile hydrides. The hydrides are purged continuously by argon or nitrogen into an appropriate atomizer of an atomic absorption spectrometer and converted to the gas-phase atoms. The sodium borohydride reducing agent, by rapid generation of the elemental hydrides in an appropriate reaction cell, minimizes dilution of the hydrides by the carrier gas and provides rapid, sensitive determinations of arsenic, antimony and selenium.

The sample is digested to solubilize particulate As, Sb and Se. The digested solutions are treated separately for determination of As, Sb and Se to convert them to As(III), Sb(III) and Se(IV) oxidation states respectively.

C.2 Interferences

Interferences are minimized because the As, Sb and Se hydrides are removed from the solution containing most potential interfering substances. Slight response variations occur when acid matrices are varied. Control these variations by treating standards and samples in the same manner. Low concentrations of noble metals (approximately 100 µg/l of Ag, Au, Pt, Pd, etc.) concentrations of Cu, Ni and Pb at or greater than 1 mg/l, and concentrations between 0,1 mg/l and 1 mg/l of hydride-forming elements (Bi, Sn and Te) can suppress the response of As, Sb and Se hydrides due to the formation of mixed metal – As-Sb or -Se compounds. The presence of As, Sb and Se in each other's matrices can cause similar suppression. Reduced nitrogen oxides resulting from HNO₃ digestion and nitrite also can suppress instrumental response for all elements. Large concentrations of iodide interfere with the Se determination by reducing Se to its elemental form. Do not use any glassware for determining Se that has been used with iodide reduction of As(V).

C.3 Reagents

All reagents shall be of a recognized analytical grade and the water used shall conform to grade 3 in accordance with EN ISO 3696.

C.3.1 Sodium tetrahydroborate (sodium borohydride)

Dissolve 8 g NaBH₄ in 200 ml of NaOH, c(NaOH) = 0,1 mol/l. Prepare fresh daily.

C.3.2 Sodium iodide, pre-reductant solution

Dissolve 50 g NaI in 500 ml water. Prepare fresh daily.

C.3.3 Sulfuric acid, solution $c(\text{H}_2\text{SO}_4) = 9 \text{ mol/l}$.

C.3.4 Sulfuric acid, solution $c(\text{H}_2\text{SO}_4) = 1,25 \text{ mol/l}$.

Cautiously add 35 ml sulfuric acid, density (ρ) = 1,84 g/ml to about 400 ml water, allow to cool, and adjust volume to 500 ml.

C.3.5 Nitric acid, density (ρ) = 1,42 g/ml.

C.3.6 Perchloric acid, density (ρ) = 1,66 g/ml.

C.3.7 Hydrochloric acid, density (ρ) = 1,16 g/ml.

C.3.8 Argon (or nitrogen), commercial grade.

C.3.9 Hydrogen, commercial grade.

C.3.10 Arsenic (III) solutions:

- stock As(III) solution: Dissolve 1,320 g arsenic trioxide, As_2O_3 , in water containing 4 g NaOH. Transfer quantitatively to 1 000 ml one-mark volumetric flask and make up to the mark with water and mix; 1,00 ml = 1,00 mg As(III);
- intermediate As(III) solution: Dilute into 1 000 ml one-mark volumetric flask 10 ml stock As (III) solution to the mark with water containing 5 ml hydrochloric acid (C.3.7) and mix; 1,00 ml = 10,0 μg As(III);
- standard As(III) solution: Dilute into 1 000 ml one-mark volumetric flask 10 ml intermediate As(III) solution to the mark with water containing the same concentration of acid used for sample preservation (2 ml to 5 ml nitric acid (C.3.5)) and mix; 1,00 ml = 0,100 μg As(III). Prepare diluted solutions daily.

C.3.11 Arsenic(V) solutions:

- stock As(V) solution: Dissolve 1,534 g arsenic pentoxide, As_2O_5 , in water containing 4 g NaOH. Transfer quantitatively to 1 000 ml one-mark volumetric flask and make up to the mark with water and mix; 1,00 ml = 1,00 mg As(V);
- intermediate As(V) solution: Prepare as for As(III) above; 1,00 ml = 10,0 μg As(V);
- standard As(V) solution: Prepare as for As(III) above; 1,00 ml = 0,100 μg As(V).

C.3.12 Selenium(IV) solutions:

- stock Se(IV) solution: Dissolve 2,190 g sodium selenite, Na_2SeO_3 in water containing 10 ml hydrochloric acid (C.3.7) and transfer quantitatively to 1 000 ml one-mark volumetric flask and make up to the mark with water and mix; 1,00 ml = 1,00 mg Se(IV);
- intermediate Se(IV) solution: Dilute into 1 000 ml one-mark volumetric flask 10 ml stock Se (IV) solution to the mark with water containing 10 ml hydrochloric acid (C.3.7) and mix; 1,00 ml = 10,0 μg Se(IV);
- standard Se(IV) solution: Dilute into 1 000 ml one-mark volumetric flask 10 ml intermediate Se(IV) solution to the mark with water containing the same concentration of acid used for sample preservation (2 ml to 5 ml nitric acid (C.3.5)) and mix. Prepare solution daily when checking the equivalent of instrument response for Se(IV) and Se(VI); 1,00 ml = 0,100 μg Se(IV).

C.3.13 Selenium(VI) solutions:

- stock Se(VI) solution: Dissolve 2,393 g sodium selenate Na_2SeO_4 in water containing 10 ml nitric acid (C.3.5). Transfer quantitatively to 1 000 ml one-mark volumetric flask and make up to the mark with water and mix; 1,00 ml = 1,00 mg Se(VI);
- intermediate Se(VI) solution: Prepare as for Se(IV) above; 1,00 ml = 10,0 μg Se(VI);
- standard Se(VI) solution: Prepare as for Se(IV) above; 1,00 ml = 0,100 μg Se(VI).

C.3.14 Antimony solutions:

- stock Sb solution: Dry 2 g of potassium antimonyl tartrate hemihydrate (antimony potassium tartrate) ($\text{C}_4\text{H}_4\text{O}_7\text{SbK} \cdot 0,5 \text{H}_2\text{O}$) at 100 °C for 1h. Dissolve 1,669 g in water transfer quantitatively to 1 000 ml one-mark volumetric flask and make up to the mark with water and mix; 1,00 ml = 1,00 mg Sb;
- intermediate Sb solution: Dilute into 1 000 ml one-mark volumetric flask 10 ml stock Sb solution to the mark with water containing 10 ml hydrochloric acid (C.3.7) and mix; 1,00 ml = 10,0 μg Sb;
- standard Sb solution: Dilute into 1 000 ml one-mark volumetric flask 10 ml intermediate Sb solution to the mark with water containing the same concentration of acid used for sample preservation (2 ml to 5 ml nitric acid (C.3.5)) and mix; 1,00 ml = 0,100 μg Sb. Prepare diluted solutions daily.

C.4 Apparatus

Ordinary laboratory apparatus and glassware, together with the following:

C.4.1 Atomic absorption spectrometer, equipped with gas flow meters for argon (or nitrogen) and hydrogen, As, Sb and Se electrodeless discharge lamps, with background correction at measurement wavelengths and appropriate strip-chart recorder.

NOTE Certain atomic absorption atomizers and hydride reaction cells are available commercially for use with the sodium borohydride reagent.

C.4.2 Atomizer

Use one of the following:

- Boling-type burner⁶⁾ head for argon (or nitrogen)-air entrained-hydrogen flame;
- cylindrical quartz cell, 10 cm to 20 cm long, electrically heated by external Ni-Cr wire to 800 °C to 900 °C;
- cylindrical quartz cell with internal fuel rich hydrogen-oxygen (air) flame.

The transparency of quartz cells deteriorates over several months of use. The transparency can be restored by treatment with 40 % hydrofluoric acid (HF).

SAFETY PRECAUTIONS: Be careful in handling HF which is toxic and corrosive and avoid prolonged contact of quartz with HF.

6) Boling is the name of the inventor of this type of burner for rapid combustion of the hydrides.

C.4.3 Reaction cell for producing As, Sb or Se hydrides

An example of reaction cell is given in Figure C.1.

NOTE A commercially available system is acceptable if it utilizes liquid sodium borohydride reagents; accepts samples digested in accordance with C.5.3, accepts between 4 mol/l to 6 mol/l (HCl) ; and is efficiently and precisely stirred by the purging gas and/or a magnetic stirrer.

Irrespective of the hydride reaction cell-atomizer system selected, it shall meet the following quality-control considerations:

- a) it shall provide a precise and reproducible calibration curve between 0 µg/l and 20 µg/l As, Sb or Se and a detection limit between 0,1 µg/l and 0,5 µg/l As, Sb or Se;
- b) when carried through the entire procedure, oxidation state couples (As(III) - As(V) or Se(IV) - Se(VI)) shall cause equal instrument response; and
- c) sample digestion shall yield 90 % or greater recovery of added As(III), As(V), Se(VI), Se(IV) or Sb.

C.4.4 Dropper and syringe capable of delivering 0,5 ml to 3,0 ml sodium borohydride reagent. Exact and reproducible addition is required so that production of hydrogen gas does not vary significantly between determinations.

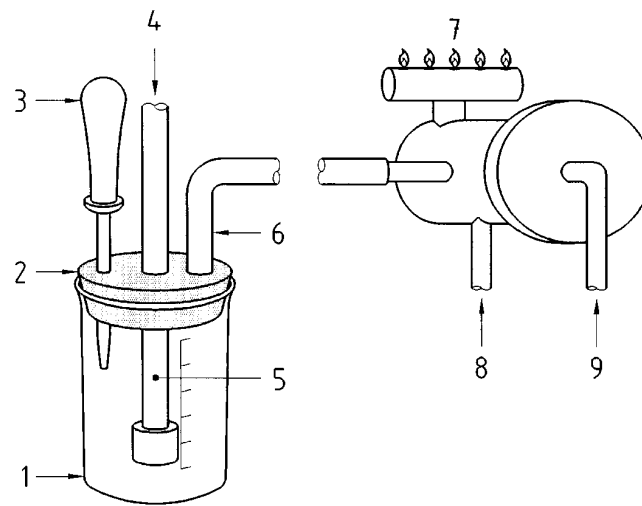

Key

- 1 Beaker 250ml
- 2 Rubber stopper
- 3 Dropper
- 4 Auxiliary nitrogen
- 5 Gas dispersion tube
- 6 Outlet tube
- 7 Burner
- 8 Hydrogen
- 9 Nitrogen

Figure C.1 - Reaction cell for producing As, Sb or Se hydrides

C.5 Procedure

C.5.1 Preparation of the apparatus

Connect inlet of reaction cell with auxiliary purging gas controlled by flow meter. If a drying cell between the reaction cell and atomizer is necessary, use only anhydrous CaCl_2 and not CaSO_4 because it can retain SeH_2 . Before using the hydride generation/analysis system, optimize operating parameters. Aspirate aqueous solutions of As, Sb and Se directly into the flame to facilitate atomizer alignment. Align quartz atomizers for maximum absorbance. Establish purging gas flow, concentration and rate of addition of sodium borohydride reagent, solution volume, and stirring rate for optimum instrument response for the chemical species to be analyzed. If a quartz atomizer is used, optimize cell temperature. If sodium borohydride reagent is added too quickly, rapid evolution of hydrogen will unbalance the system. If the volume of solution being purged is too large, the absorption signal will be decreased. Recommended wavelengths are 193,7 nm 196,0 nm and 217,6 nm for As, Se and Sb, respectively.

C.5.2 Preparation of calibration solutions

Transfer 0,00 ml; 1,00 ml; 2,00 ml; 5,00 ml; 10,00 ml; 15,00 ml and 20,00 ml of standard solutions of As(III), Se(IV) or Sb to 100 ml volumetric flasks and make up to the mark with water containing the same acid

concentration used for sample preservation (commonly 2 ml to 5 ml nitric acid (C.3.5)). This yields calibrations solutions of 0 µg/l, 1 µg/l, 2 µg/l, 5 µg/l, 10 µg/l, 15 µg/l and 20 µg/l As, Se or Sb. Prepare fresh daily.

C.5.3 Preparation of test solutions and standard solutions

Add 50 ml of the sample or As(III), Se(VI) or Sb standard solution to 250 ml beaker. Alternatively, prepare standard solutions by adding aliquots of solutions containing 5 µg As, Se or Sb directly to the beaker and dilute to 50 ml in this beaker, thus achieving a concentration of 100 µg/l of the respective solutions. Add 7 ml sulfuric acid $c(\text{H}_2\text{SO}_4) = 9 \text{ mol/l}$ (C.3.3) and 5 ml nitric acid (C.3.5). Add a small boiling chip or glass beads if necessary. Evaporate to SO_3 fumes. Maintain oxidizing conditions at all times by adding small amounts of nitric acid, to prevent solution from darkening.

Maintain an excess of nitric acid until all organic matter is destroyed. Complete digestion usually is indicated by a light-coloured solution. Cool slightly, add 25 ml water and 1 ml of perchloric acid (C.3.6) and again evaporate to SO_3 fumes to expel oxides of nitrogen.

Monitor effectiveness of digestion procedure used by adding 5 ml of a standard arsenic solution, 5 ml of a standard selenium solution or 5 ml of a standard antimony solution to 50 ml of the sample and measuring recovery. Average recoveries shall be greater than 90 %. Alternatively, use 100 ml micro-Kjeldahl flasks for the digestion of total recoverable arsenic, selenium or antimony, thereby improving digestion effectiveness. After final evaporation of SO_3 fumes, dilute to 50 ml for arsenic measurements or 30 ml for selenium and antimony measurements.

C.5.4 Determination of arsenic with sodium borohydride

To 50 ml of the digested standard solution or test solution in a 250 ml beaker (see Figure C.1) add 5 ml hydrochloric acid (C.3.7) and mix. Add 5 ml sodium iodide pre-reductant solution (C.3.2), mix and wait at least 30 min.

NOTE The sodium iodide has not been found necessary for certain hydride reaction cell designs if a 20 % to 30 % loss in instrument sensitivity is not important and variables of solution acid conditions, temperatures, and volumes for production of As(V) and arsine can be controlled strictly. This can require an automated delivery system.

Attach one beaker at a first time to the rubber stopper containing the gas dispersion tube for the purging gas, the sodium borohydride reagent inlet, and the outlet to the atomizer. Turn on strip-chart recorder and wait until the base line is established by the purging gas and all air is expelled from the reaction cell. Add 0,5 ml sodium borohydride reagent (C.3.1). After the instrument absorbance has reached a maximum and returned to the base line, remove beaker, rinse dispersion tube with water, and proceed to the next test solution or standard solution. Periodically compare standard As(III) and As(V) curves for response consistency. Check for presence of chemical interferences that suppress instrument response for arsine by treating a digested sample with 10 µg/l As(III) or As(V) as appropriate. Average recoveries shall be not less than 90 %.

C.5.5 Determination of selenium with sodium borohydride

To 30 ml of the digested standard solution or test solution, or to 30 ml of the undigested standard, or the sample in a 250 ml beaker, add 15 ml hydrochloric acid (C.3.7) and mix. Heat for a predetermined period at temperature between 90 °C to 100 °C. Alternatively autoclave at 121 °C in capped containers for 60 min, or heat for a predetermined time in open test tubes using a 90 °C to 100 °C hot water bath or an aluminium block digester. Check effectiveness of the selected heating by demonstrating equal instrument responses for calibration curves prepared either from standard Se(IV) or from Se(VI) solutions. Effective heat exposure for converting Se(VI) to Se(IV), with no loss of Se(IV), ranges between 5 min to 60 min when open beakers or test tubes are used. Do not digest standard Se(IV) and Se(VI) solutions used for this check of equivalency. After pre-reduction of Se(VI) and Se(IV) attach beakers, one at a time, to the purge apparatus. For each, turn on the strip-chart recorder and wait until the base line is established. Add 0,50 ml sodium borohydride reagent (C.3.1). After the instrument absorbance has reached a maximum and returned to the base line, remove beaker, rinse dispersion tube with water and proceed to the next test solution or standard solution. Check for

presence of chemical interferences that suppress selenium hydride instrument response by treating a digested sample with 10 µg/l Se(IV). Average recoveries shall be not less than 90 %.

C.5.6 Determination of antimony with sodium borohydride

To 30 ml of the digested standard solution or the test solution, or to 30 ml of the undigested standard solution, or the test solution in a 250 ml beaker, add 15 ml hydrochloric acid (C.3.7) and mix. Heat for a predetermined period (between 5 min and 60 min) at a temperature between 90 °C to 100 °C. After prereduction of Sb attach beakers, one at a time, to the purge apparatus. For each, turn on the strip-chart recorder and wait until the base line is established. Add 0,50 ml sodium borohydride reagent (C.3.1). After the instrument absorbance has reached a maximum and returned to the base line, remove beaker, rinse dispersion tube with water and proceed to the next test solution or standard solution. Check for presence of chemical interferences that suppress antimony hydride instrument response by treating a digested sample with 10 µg/l Sb. Average recoveries shall be not less than 90 %.

C.6 Calculation

Determine the calibration curve by plotting peak heights of standard solutions versus concentration. Measure peak heights of samples and read concentrations from the calibration curve. If sample was diluted (or concentrated) before sample digestion, apply an appropriate factor.

The absolute difference between two single test results, obtained under repeatability conditions, shall not be greater than the repeatability value, r , as calculated from the following equation:

$$r = 0,001 z \quad (C.1)$$

where

z is the mean of the two results, expressed in mass fraction in % .

NOTE Repeatability conditions are conditions where mutually independent test results are obtained with the same method on identical test material in the same laboratory by the same operator using the same equipment within short intervals of time.

Bibliography

- [1] 98/83/EC, *Council Directive of 3rd November 1998 on the quality of water intended for human consumption.*
- [2] 67/548/EEC, *Council Directive of 27th June 1967 on the approximation of the laws, regulations and administrative provisions relating to the classification, packaging and labelling of dangerous substances, and its amendments and adaptations.*

BSI Group
Headquarters 389
Chiswick High Road,
London, W4 4AL, UK
Tel +44 (0)20 8996 9001
Fax +44 (0)20 8996 7001
www.bsigroup.com/
standards

BSI - British Standards Institution

BSI is the independent national body responsible for preparing British Standards. It presents the UK view on standards in Europe and at the international level. It is incorporated by Royal Charter.

Revisions

British Standards are updated by amendment or revision. Users of British Standards should make sure that they possess the latest amendments or editions.

It is the constant aim of BSI to improve the quality of our products and services. We would be grateful if anyone finding an inaccuracy or ambiguity while using this British Standard would inform the Secretary of the technical committee responsible, the identity of which can be found on the inside front cover. Tel: +44 (0)20 8996 9000. Fax: +44 (0)20 8996 7400.

BSI offers members an individual updating service called PLUS which ensures that subscribers automatically receive the latest editions of standards.

Buying standards

Orders for all BSI, international and foreign standards publications should be addressed to Customer Services. Tel: +44 (0)20 8996 9001. Fax: +44 (0)20 8996 7001 Email: orders@bsigroup.com You may also buy directly using a debit/credit card from the BSI Shop on the Website <http://www.bsigroup.com/shop>

In response to orders for international standards, it is BSI policy to supply the BSI implementation of those that have been published as British Standards, unless otherwise requested.

Information on standards

BSI provides a wide range of information on national, European and international standards through its Library and its Technical Help to Exporters Service. Various BSI electronic information services are also available which give details on all its products and services. Contact Information Centre. Tel: +44 (0)20 8996 7111 Fax: +44 (0)20 8996 7048 Email: info@bsigroup.com

Subscribing members of BSI are kept up to date with standards developments and receive substantial discounts on the purchase price of standards. For details of these and other benefits contact Membership Administration. Tel: +44 (0)20 8996 7002 Fax: +44 (0)20 8996 7001 Email: membership@bsigroup.com

Information regarding online access to British Standards via British Standards Online can be found at <http://www.bsigroup.com/BSOL>

Further information about BSI is available on the BSI website at <http://www.bsigroup.com>.

Copyright

Copyright subsists in all BSI publications. BSI also holds the copyright, in the UK, of the publications of the international standardization bodies. Except as permitted under the Copyright, Designs and Patents Act 1988 no extract may be reproduced, stored in a retrieval system or transmitted in any form or by any means – electronic, photocopying, recording or otherwise – without prior written permission from BSI.

This does not preclude the free use, in the course of implementing the standard, of necessary details such as symbols, and size, type or grade designations. If these details are to be used for any other purpose than implementation then the prior written permission of BSI must be obtained.

Details and advice can be obtained from the Copyright and Licensing Manager. Tel: +44 (0)20 8996 7070 Email: copyright@bsigroup.com

Draft for comments only — Not to be cited as East African Standard