



CD/K/036:2009
ICS 91.140.60

EAST AFRICAN STANDARD

Cisterns for domestic use — Cold water storage and combined feed and expansion (thermoplastic) cisterns up to 500 l — Specification

EAST AFRICAN COMMUNITY

Foreword

Development of the East African Standards has been necessitated by the need for harmonizing requirements governing quality of products and services in East Africa. It is envisaged that through harmonized standardization, trade barriers which are encountered when goods and services are exchanged within the Community will be removed.

In order to meet the above objectives, the EAC Partner States have enacted an East African Standardization, Quality Assurance, Metrology and Test Act, 2006 (EAC SQMT Act, 2006) to make provisions for ensuring standardization, quality assurance, metrology and testing of products produced or originating in a third country and traded in the Community in order to facilitate industrial development and trade as well as helping to protect the health and safety of society and the environment in the Community.

East African Standards are formulated in accordance with the procedures established by the East African Standards Committee. The East African Standards Committee is established under the provisions of Article 4 of the EAC SQMT Act, 2006. The Committee is composed of representatives of the National Standards Bodies in Partner States, together with the representatives from the private sectors and consumer organizations. Draft East African Standards are circulated to stakeholders through the National Standards Bodies in the Partner States. The comments received are discussed and incorporated before finalization of standards, in accordance with the procedures of the Community.

Article 15(1) of the EAC SQMT Act, 2006 provides that "Within six months of the declaration of an East African Standard, the Partner States shall adopt, without deviation from the approved text of the standard, the East African Standard as a national standard and withdraw any existing national standard with similar scope and purpose".

East African Standards are subject to review, to keep pace with technological advances. Users of the East African Standards are therefore expected to ensure that they always have the latest versions of the standards they are implementing.

© East African Community 2010 — All rights reserved*

East African Community

P O Box 1096

Arusha

Tanzania

Tel: 255 27 2504253/8

Fax: 255-27-2504481/2504255

E-Mail: eac@eachq.org

Web: www.each.int

Introduction

In the preparation of this East African Standard, the following source was consulted extensively:

BS 4213:2004, *Cisterns for domestic use — Cold water storage and combined feed and expansion (thermoplastic) cisterns up to 500 l — Specification*

Assistance derived from this source and others inadvertently not mentioned is hereby acknowledged.

Draft for comments only — Not to be cited as East African Standard

Cisterns for domestic use — Cold water storage and combined feed and expansion (thermoplastic) cisterns up to 500 l — Specification

ICS 91.140.60

Committees responsible for this British Standard

The preparation of this British Standard was entrusted to Technical Committee PRI/62, Static thermoplastics tanks, upon which the following bodies were represented:

- Association of Tank and Cistern Manufacturers
- British Chemical Distributors and Traders
- British Plastics Federation
- Chemical Industries Association (CIA)
- Federation of Petroleum Suppliers
- Institute of Materials, Minerals and Mining
- Oil Firing Technical Association (OFTEC)
- Water UK
- Welding Institute
- Co-opted members

This British Standard was published under the authority of the Standards Policy and Strategy Committee on 10 March 2004.

© BSI 10 March 2004

First published October 1967
Second edition September 1975
Third edition August 1986
Fourth edition May 1991
Fifth edition March 2004

The following BSI references relate to the work on this British Standard:
Committee reference PRI/62
Draft for comment: 02/122802 DC

Amendments issued since publication

Amd No.	Date	Comments

ISBN 0 580 43333 1

Contents

	Page
Committees responsible	Inside front cover
Foreword	ii
<hr/>	
1 Scope	1
2 Normative references	1
3 Terms and definitions	1
4 General	2
5 Materials	3
6 Configuration	3
7 Performance requirements	3
8 Covers	6
9 Marking	7
10 Additional fittings	8
<hr/>	
Annex A (informative) Notes on installation of cisterns	10
Annex B (normative) Method of test for determination of toluene extract of carbon black	10
Annex C (normative) Sampling and testing	11
Annex D (normative) Methods of test for resistance to deformation	12
Annex E (normative) Method of test for resistance to deflection	13
Annex F (normative) Method of test for fatigue resistance	15
Annex G (normative) Method of test for impact resistance	15
Annex H (normative) Method of test for tensile strength and elongation at break	15
Annex I (normative) Method of test for resistance to reversion	16
Annex J (normative) Method of test for resistance to sprue strain	16
Annex K (normative) Method of test for resistance to delamination	17
Annex L (normative) Method of test for weathering	17
Annex M (normative) Method of test for hot water resistance	17
Annex N (normative) Method of test for closeness of cover fitting	19
Annex O (normative) Method of test for the assessment of ingress of particles	21
Annex P (normative) Method of test for determining the impact resistance of covers	22
Annex Q (normative) Method of test for thermal insulation	22
<hr/>	
Bibliography	25
<hr/>	
Figure 1 — Installation instructions	7
Figure D.1 — Centreline measurement	13
Figure E.1 — Arrangement for the deflection test and fatigue test	14
Figure M.1 — Typical installation for hot water test: elevation	18
Figure M.2 — Typical installation for hot water test: plan view	19
Figure N.1 — Typical installation for cover fitting test	20
Figure O.1 — Typical installation of cistern in test box for the particle ingress test	21
Figure Q.1 — Apparatus for the insulation test	23
<hr/>	
Table 1 — Position of water line	2
Table 2 — Types of delamination	5
Table C.1 — Type tests	11
Table C.2 — Routine tests	12
Table I.1 — Testing conditions for reversion and sprue strain	16
Table K.1 — Immersion media	17

Foreword

This British Standard has been prepared by Technical Committee PRI/62. It supersedes BS 4213:1991, which will be withdrawn three months after the publication date of this revision.

The specification covers cisterns up to 500 l capacity from which water is drawn for domestic purposes. It provides methods of test for the evaluation of the properties of cisterns and covers made by any of the processes currently available.

This new edition represents a full revision of the standard. It takes into account the Water Supply (Water Quality) Regulations 2001 [1], the Water Supply (Water Quality) (Scotland) Regulations 2001 and subsequent amendments [2] and the Water Supply (Water Quality) Regulations (Northern Ireland) 2002 and subsequent amendments [3], which include detailed provisions to safeguard the integrity of stored water for domestic (i.e. drinking, washing, cooking and sanitary) purposes. It also takes into account EC Directive 98/83/EC [4], which implies that water quality from any domestic draw-off point should be of drinking water quality. It includes requirements for both cisterns and their associated fittings to assist in safeguarding against waste and contamination, and insulation requirements to reduce the likelihood of the stored water freezing or warming. It also gives a method of test for the assessment of the ingress of particles and insects.

As in the previous editions, the specification is confined to cisterns produced from thermoplastics, although an outer reinforcing layer of an unspecified composition is permitted.

As a result of problems encountered when analysing processed material, this British Standard requires all materials to conform to BS 6920-1. The details of the analytical methods for determining the permitted antioxidants are not given in this British Standard, but reference is made to the relevant methods in BS 2782.

Because slight changes are necessary in plumbing practice when using thermoplastics cisterns as opposed to more rigid materials, additional recommendations for installation are given in Annex A.

Upon publication of this revision, BSI Sales Department will respond to purchase orders for BS 4213 by supplying copies of the 2004 edition. Copies of the 1991 edition may be obtained until it is withdrawn by quoting BS 4213:1991.

This publication does not purport to include all the necessary provisions of a contract. Users are responsible for its correct application.

Compliance with a British Standard does not of itself confer immunity from legal obligations.

Summary of pages

This document comprises a front cover, an inside front cover, pages i and ii, pages 1 to 25 and a back cover.

The BSI copyright notice displayed in this document indicates when the document was last issued.

1 Scope

This British Standard specifies requirements for the materials, physical properties and performance of cold water storage cisterns and combined feed and expansion cisterns of up to 500 l capacity, from which water is drawn for domestic purposes. It also specifies requirements for the associated fittings of such cisterns, i.e. covers, screened breathers, screened warning pipes and vent pipe entry devices, and for cistern insulation. It gives methods of test for the evaluation of the properties of cisterns and covers made by any of the processes currently available.

This British Standard applies only to cisterns that are manufactured from thermoplastics, and that have covers manufactured either from thermoplastics or from other manufactured materials having a thermoplastics layer on the inside face. It covers both circular and non-circular cisterns, but does not apply to flushing cisterns.

2 Normative references

The following referenced documents are indispensable for the application of this document. For dated references, only the edition cited applies. For undated references, the latest edition of the referenced document (including any amendments) applies.

BS 1566-1:2002, *Copper indirect cylinders for domestic purposes — Part 1: Open vented copper cylinders — Requirements and test methods.*

BS 2071, *Specification for Soxhlet extractors.*

BS 2782-4:Method 452B, *Methods of testing plastics — Chemical properties — Determination of carbon black content of polyolefin compound.*

BS 2782-8:Methods 823A and 823B:1978, *Methods of testing plastics — Other properties — Methods for the assessment of carbon black dispersion in polyethylene using a microscope.*

BS 4781, *Specification for pressure-sensitive adhesive plastics labels for permanent use.*

BS 6920-1, *Suitability of non-metallic products for use in contact with water intended for human consumption with regard to their effect on the quality of the water — Part 1: Specification.*

BS EN 1057, *Copper and copper alloys — Seamless, round copper tubes for water and gas in sanitary and heating applications.*

BS EN 60335-2-73, *Specification for safety of household and similar electrical appliances — Part 2: Particular requirements — Section 2-73: Fixed immersion heaters.*

BS EN ISO 527-1 (BS 2782-3:Method 321), *Plastics — Determination of tensile properties — Part 1: General principles.*

BS EN ISO 4892-2, *Plastics — Methods of exposure to laboratory light sources — Part 2: Xenon-arc sources.*

3 Terms and definitions

For the purposes of this British Standard the following definitions apply.

3.1

additional fitting kit

assembly of additional fittings for a cistern

3.2

capacity

volume of a cistern measured up to the water line

3.3 cisterns

3.3.1

cistern

fixed container for holding water at atmospheric pressure

NOTE The water is usually supplied through a float-operated valve.

3.3.2

cold water storage cistern

cistern, including cover and additional fitting kit (3.1), used only for storing cold water for domestic (i.e. drinking, washing, cooking and sanitary) purposes

3.3.3

combined feed and expansion cistern

cistern used for supplying water to and receiving expansion water from a hot water system

3.4 pipes

3.4.1

breather

pipe or hole which allows the free exchange of air when the cistern is emptying and filling and which preserves the integrity of the stored water

3.4.2

warning pipe

pipe that indicates fault conditions, fixed so that its outlet, whether inside or outside the building, is in a conspicuous position where the discharge of water can be seen

3.4.3

vent pipe

pipe open to the atmosphere and used in connection with a hot water system for the escape of air and/or steam

3.5

top of a cistern

plane across the highest point of a cistern excluding any extension of the cistern provided for supporting or securing the removable cover

NOTE This definition applies to cisterns with part integral or integral covers only.

3.6

water line

line marked inside a cistern to indicate the highest water level at which the float-operated valve (or other water inlet-control device) should be adjusted to shut off

4 General

The wall thickness of a cistern shall be not less than 1.5 mm.

The water line position as specified in Table 1 shall be clearly and durably marked by moulded impression on the wall of the cistern.

Table 1 — Position of water line

Cistern type reference ^a	Minimum capacity to water line l (gallon) ^b	Minimum distance of water line from top of cistern mm
Up to and including XX8	38 (8)	≥110
Including and above XX15	68 (15)	≥115
^a See 9.1.		
^b 1 gallon = 4.546 09 l		

5 Materials

5.1 General

All materials used for cisterns, covers and additional fittings that are, or are likely to be, in contact with water (including condensation) shall conform to the requirements of BS 6920-1.

5.2 Carbon black

Where carbon black is used it shall conform to the following requirements.

- a) When tested in accordance with BS 2782-4:Method 452B, the carbon content shall be not less than 0.5 % and not greater than 3.0 %.
- b) The density shall be $\geq 1.5 \text{ g/cm}^3$ and $\leq 2.0 \text{ g/cm}^3$.
- c) The total amount of volatile matter shall not exceed a mass fraction of 9.0 %.
- d) The average particle size shall be not less than 0.010 μm and not greater than 0.025 μm .
- e) When determined in accordance with Annex B, the total amount of toluene extract shall not exceed a mass fraction of 0.10 %.
- f) When tested in accordance with BS 2782-8:Method 823A, the carbon black dispersion in the cistern shall show a numerical rating of 3 or less and the uniformity of appearance in respect of smears and streaks shall be equal to or better than photomicrograph A of BS 2782-8:Method 823A:1978, Figure 1.

5.3 Rework

No rework material, other than the addition of a mass fraction no greater than 15 % of the manufacturer's own rework material of the same type, resulting from the manufacture of cisterns conforming to the requirements of this British Standard, shall be used.

6 Configuration

Where a change in direction of the cistern wall is necessary, this shall be accomplished by the use of a radius not less than 3 mm. Where the walls of a cistern within 115 mm of the top or bottom of the cistern are tapered, the taper shall not exceed 5° from the vertical, except where ribs are positioned. Where a connection passes through the cistern, a means of excluding external condensate shall be provided.

NOTE 1 The cistern surface should have an even texture and should be free from surface imperfections, which detract from the performance of the cistern in use.

NOTE 2 Any backing plate for a float-operated valve to be fixed externally to the cistern is normally supplied treated to prevent corrosion, free from sharp edges or sharp corners and drilled to provide a 22 mm diameter hole.

NOTE 3 Ribs should not interfere with pipe installation.

7 Performance requirements

7.1 General

The tests cited in 7.2 to 7.11 shall be carried out as either type tests or routine tests in accordance with Annex C.

7.2 Resistance to deformation

7.2.1 Circular cisterns

When tested in accordance with Annex D, method 1, the difference between the circumferential measurements of a circular cistern shall be not greater than 2 % of the original circumferential measurement.

7.2.2 Non-circular cisterns

When tested in accordance with Annex D, method 2, the deformation in either direction of a non-circular cistern shall be not greater than 2 %.

7.3 Resistance to deflection

When measured in accordance with Annex E, the deflection shall not exceed 32 mm.

7.4 Fatigue resistance

When tested in accordance with Annex F, there shall be no cracking of the cistern in the region of the inlet hole.

7.5 Impact resistance

When tested in accordance with Annex G, any impact shall neither split nor puncture the cistern.

7.6 Tensile strength and elongation at break

When tested in accordance with Annex H, the ultimate tensile strength of the polyolefin fitting of the wall of the cistern shall be not less than 7.6 MPa.

The percentage elongation at break of the specimens from both horizontal and vertical axes shall be not less than:

- a) 100 % for polyethylene;
- b) 50 % for polypropylene.

7.7 Resistance to reversion

NOTE This requirement is applicable to injection moulded cisterns only.

When tested in accordance with Annex I, each specimen taken from a single cistern shall have a percentage reversion not greater than:

- a) 5.0 % for polyethylene with a density less than 0.94 g/cm³;
- b) 3.0 % for polyethylene with a density of 0.94 g/cm³ and above;
- c) 2.0 % for polypropylene.

7.8 Resistance to sprue strain

NOTE This requirement is applicable to injection moulded cisterns only.

When tested in accordance with Annex J, any slit opening on each specimen taken from a single cistern shall be not greater than 0.76 mm.

7.9 Resistance to delamination

NOTE This requirement is applicable to injection moulded cisterns only.

When tested in accordance with Annex K, the delamination at 50 °C on each specimen taken from a single cistern shall not be inferior to type 2 of Table 2.

7.10 Weathering

NOTE This requirement is not applicable to cisterns with a carbon black content greater than a mass fraction of 0.5 %.

For cisterns with a carbon black content less than a mass fraction of 0.5 %, when tested in accordance with Annex L, the elongation at break on each specimen taken from a single cistern shall be not less than 50 % of the value obtained from the unweathered material from the same cistern.



7.11 Hot water resistance

When tested in accordance with Annex M:

- a) there shall be no overflow from the top edge of the cistern or any other visible signs of leakage;
- b) there shall be no distortion of the cistern that might impair the function and operation of the float-operated valve;
- c) after the conclusion of the heating cycle and when the water has been left to cool for (120^{+15}_0) min, it shall be possible to replace the cover recommended by the manufacturer.

NOTE Deflecting the sides of the cistern in order to replace the cover, and contact between the turned-down edges of the cover and the cistern sides, is permissible provided that the cover remains in position with its edges overlapping the cistern at all points.

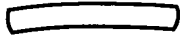
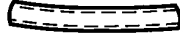
Table 2 — Types of delamination

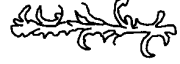
Example	Type	Description
	Type 0	No signs of delamination
	Type 1	Small fissure along exposed face, no surface peeling
	Type 2	Peeling from specimen ends only
	Type 3	Extensive surface peeling, deep fissure long exposed face, lifted skin sections greater than 6.4 mm
	Type 4	Small coiled peeling superimposed on lifted skin sections, deep fissures along exposed surface

8 Covers

8.1 General

The tests cited in 8.2, 8.3, 8.4 and 8.5 shall be carried out as either type tests or routine tests in accordance with Annex C.

8.2 Fit of the cover

With the exception of XX4 cisterns supplied with a loose fitting cover for use as a combined feed and expansion cistern (see Note to 10.1), cisterns shall have a close fitting rigid cover secured by mechanical means. Where a connection passes through the cover, a means of excluding external condensate shall be provided.

The degree of close fitting of the cover shall be such that it does not become detached from the cistern when tested in accordance with Annex N.

8.3 Materials for covers

Materials used for covers shall conform to BS 6920-1 (see 5.1) and shall be either:

- a) thermoplastics conforming to 5.1, except that up to 100 % of rework material is permitted to be used in the construction of the cover; or
- b) other materials having a layer of thermoplastics on the whole inside face of the cover. The thickness of this layer at any point shall be not less than 0.125 mm.

8.4 Construction of covers

8.4.1 Covers shall be so designed that no point on the underside of a cover is less than 127 mm (122 mm for cistern sizes less than XX8) above the water line, except for a margin extending 50 mm from the top of the side wall of the cistern.

8.4.2 When a cover and cistern are tested in accordance with the appropriate method in Annex D and subsequently tested in accordance with Annex O, all particles retained by the filter paper or bag in the air extraction line shall have at least two dimensions of not less than 0.65 mm.

NOTE This requirement is not applicable to the loose fitting covers supplied with the XX4 cisterns described in the note to 10.1.

8.5 Impact resistance of covers

When a cover is tested in accordance with Annex P, the impact shall neither cause a split nor puncture the cover.

8.6 Float-operated valve clearance

On application of a mass of 2.5 kg over a maximum area of 200 mm × 200 mm above the centre point of a cover, the underside of the cover shall at no point, excepting the marginal area referred to in 8.4.1, reduce the clearance to the water line below 115 mm (110 mm for cistern sizes less than XX8) at any time during a period of 7 days. The maximum depression of the marginal area below the top plane of the cistern shall not exceed 10 mm.

9 Marking

9.1 Designation

Each cistern shall be designated by a code comprising components in the following order:

- a) number and date of this British Standard, i.e. BS 4213:2004¹⁾;
- b) one or two capital letters of the manufacturer's choice, followed by a number representing the capacity in gallons derived from the capacity measured in litres (rounded to the nearest whole gallon);
- c) a capital letter to denote the cistern shape:
 - 1) C shall be used to denote a circular cistern;
 - 2) R shall be used to denote a rectangular cistern;
 - 3) X shall be used to denote any other shape of cistern.

EXAMPLE A rectangular 114 l (25 gallon) cistern might be designated BS 4213:2004:PT25R or BS 4213:2004:K25R.

9.2 Marking of cisterns

All cisterns shall be clearly and durably marked by moulded impression, or shall carry a waterproof adhesive label conforming to BS 4781, with the following information:

- a) the manufacturer's name or trade mark;
- b) the cistern designation (see Clause 9);
- c) the installation instructions given in Figure 1, except that item h) shall be omitted for XX4 cisterns supplied with a loose fitting cover for use as a combined feed and expansion cistern (see Note to 10.1).

INSTALLATION INSTRUCTIONS

- a) The centreline of the float-operated valve shall be a minimum of (60 ± 5) mm from the top of the cistern.
 - b) The platform on which the cistern sits shall be made of a suitably strong, rigid flat material, and shall be level. This platform shall be larger than the base of the cistern.
- WARNING.** It is most important for safety reasons that the base of the cistern is adequately and uniformly supported over its whole area once installed in its final position.
- c) Pipes shall be supported and aligned so as not to distort the cistern and back nuts shall not be overtightened.
 - d) No putty or joining compound shall be used. Plastics or rubber sealing washers shall be used.
 - e) Circular holes for fixing pipes shall have a clean edge, free from notches, and shall be punched with a sharp hollow punch, cut with a hole saw or drilled with a sharp cutter. Scratching or scoring the cistern shall not be used for setting out the holes.
 - f) Support washers of brass, rigid plastics or metal, suitably protected, shall be fitted internally and externally to all underwater pipe connections.
 - g) The cistern shall be so positioned that it is not in close proximity to heaters, electric light bulbs or other sources of heat.
 - h) Install with fixed cover, screened breather, screened warning pipe and if applicable vent pipe entry device and insulation.

Figure 1 — Installation instructions

¹⁾ Marking BS 4213:2004 on or in relation to a product represents a manufacturer's declaration of conformity, i.e. a claim by or on behalf of the manufacturer that the product meets the requirements of the standard. The accuracy of the claim is solely the claimant's responsibility. Such a declaration is not to be confused with third-party certification of conformity.

9.3 Marking of covers

Covers shall be clearly and durably marked by moulded impression, or shall carry a waterproof adhesive label conforming to BS 4781, with the following information:

- a) the manufacturer's name or trade mark;
- b) the nominal capacity of the cistern in gallons with which the cover is intended to be used.

10 Additional fittings

10.1 General

All cisterns, except for XX4 cisterns under specific circumstances (see Note), shall have the following additional fittings, which shall be either fitted to the cistern during manufacture or supplied as an additional fitting kit for the installer to assemble:

- a) breather (see 10.2);
- b) vent pipe entry device (see 10.3);
- c) screened warning pipe termination assembly (see 10.4);
- d) thermal insulation (see 10.5).

NOTE An XX4 cistern (header tank) may be supplied with a loose fitting cover for use as a combined feed and expansion cistern only. In such cases, the additional fittings are not required.

The assembled installation shall conform to the requirements specified in 10.6.

Where these items are supplied as an additional fitting kit, it shall additionally conform to the requirements specified in 10.7.

10.2 Screened breather (breather)

The breather shall have a screen with apertures not exceeding 0.5 mm × 0.5 mm, to prevent the ingress of insects and particles greater than 0.65 mm in diameter.

The total unobstructed area of the inlet and screen shall be not less than 200 mm². The inlet shall be shrouded to alleviate dust entry and build-up of dust and to prevent the entry of light.

10.3 Vent pipe entry device

A fixing, connection or other device shall be provided to allow entry of a vent pipe.

NOTE Such a device should prevent any displacement or distortion of the cistern or cover due to expansion or other movement of the vent pipe.

10.4 Screened warning pipe termination assembly

A warning pipe termination assembly shall be provided for fitting through the side wall of the cistern and connection to an external warning pipe. It shall incorporate the following:

- a) a turn-down inside the cistern with its outlet (50 ± 10) mm below the shut-off water level;
- b) a free-draining watertight housing containing a screen (designed so that any water having been in contact with the screen cannot re-enter the cistern), for fitting to the warning pipe outside the cistern. The screen shall have apertures not exceeding 0.5 mm × 0.5 mm, shall not restrict the full flow of the warning pipe and shall be easily removable for inspection and cleaning.

10.5 Thermal insulation

NOTE Insulation slows down but does not stop the loss of heat from the water. No amount of insulation will give complete protection if the ambient temperature continues indefinitely at or below freezing point. However, suitable insulation can delay the onset of freezing and so provide worthwhile protection.

The thermal insulation shall be appropriate for the shape and size of the cistern and shall not allow a fall of water temperature of more than 10 °C when tested in accordance with Annex Q.

In the case of loose-fill insulation, a means shall be provided to retain the insulation material where the installer is required to cut holes.

Where the insulation is incorporated as an integral part of the cistern construction, it shall be so positioned as to minimize the possibility of obstruction. Where it is supplied as part of an additional fitting kit, it shall be supplied with the necessary assembly instructions, which shall include an instruction to position the insulation so as to minimize the possibility of obstruction.

10.6 Particle ingress limitation between the cistern and fittings

When the assembled installation is tested in accordance with Annex O, all particles retained by the filter paper or bag in the air extraction line shall have at least two dimensions of not less than 0.65 mm.

10.7 Additional fitting kit

Where the additional fittings are supplied as an additional fitting kit to be assembled by the installer:

- a) the necessary assembly instructions (see also 10.5) shall be supplied, together with a contents list;
- b) the additional fitting kit shall be clearly and indelibly labelled with the following information:
 - 1) the statement "This additional fitting kit conforms to the requirements of BS 4213:2004"²⁾;
 - 2) cistern manufacturer's name or trade mark;
 - 3) instructions stating which of the fittings are only suitable for a specific size of cistern.

²⁾ Marking BS 4213:2004 on or in relation to a product represents a manufacturer's declaration of conformity, i.e. a claim by or on behalf of the manufacturer that the product meets the requirements of the standard. The accuracy of the claim is solely the claimant's responsibility. Such a declaration is not to be confused with third-party certification of conformity.

Annex A (informative)

Notes on installation of cisterns

Cisterns should be installed in accordance with the following recommendations.

- a) When a float-operated valve backing plate is supplied loose, it should be fitted to the outside of the cistern with the centre of the hole positioned (60 ± 5) mm from the top of the cistern.
- b) The base of the cistern should be fully supported over its whole area by a durable, rigid, flat and level platform sufficiently strong so that when the cistern is filled with water the deflection of the base does not exceed 2 mm.
- c) Pipes connected to the cistern should be supported and aligned so as not to distort the cistern and back nuts should not be overtightened.
- d) Plastics or rubber washers should be used both inside and outside the cistern. Under no circumstances should jointing compounds or putty be employed in contact with thermoplastics cisterns. PTFE (polytetrafluoroethylene) unsintered tape may be wrapped around the threaded sections of valves or connectors to act as a sealant.
- e) Circular holes for fixing pipes should have a clean edge free from notches and should be capable of being punched with a sharp hollow punch, cut with a hole saw or drilled with a sharp cutter. Scratching or scoring the cistern should not be used for setting out holes.
- f) The cistern should be so positioned that it is not in close proximity to heaters, electrical light bulbs or other sources of heat.
- g) Where the cistern section has a change in profile, which is accomplished with a radius, it is essential that the outer extremities of the pipe flange connection and washer are clear of this radius.
- h) All underwater connections should be fitted with rigid plastic, brass or other suitably protected metal support washers.

NOTE The dimensional details given in this annex are based on a float valve conforming to BS 1212-2.

Annex B (normative)

Method of test for determination of toluene extract of carbon black

B.1 Apparatus and reagent

- B.1.1 *Paper extraction thimbles*, double thickness, fat extracted.
- B.1.2 *Toluene*, sulfur-free.
- B.1.3 *Soxhlet extractor*, conforming to BS 2071.
- B.1.4 *Shallow borosilicate glass weighing dish*, 50 ml capacity, cleaned, dried and tared.

B.2 Procedure

- B.2.1 Place 5 g to 8 g of pelletized carbon black or 2 g to 5 g of compressed fluffy black in an extraction thimble (B.1.1). Measure 50 ml to 60 ml of toluene (B.1.2) into the Soxhlet flask (B.1.3).
- B.2.2 Assemble the Soxhlet extraction apparatus and extract for 22 h.
- B.2.3 Transfer the extract solution into the weighing dish (B.1.4). Filter, if necessary, rinse the extraction flask with toluene and add to the weighing dish. Evaporate the total solution on a hotplate to a volume of approximately 5 ml to 10 ml and then place in a drying oven at 115 °C until dry.
- B.2.4 Cool in a desiccator to room temperature and weigh.

B.3 Calculation

Calculate the toluene extract as follows:

$$T_E = \frac{M_E}{M_S} \times 100$$

where

M_E is the mass of extract, in grams (g);

M_S is the mass of the sample, in grams (g);

T_E is the mass fraction of toluene extract, as a percentage (%).

Annex C (normative) Sampling and testing

C.1 Type testing

The tests specified in Table C.1 shall be carried out as type tests.

Samples for type testing shall be selected in the following circumstances:

- when the method of production is altered in a way that affects type test performance;
- when the manufacturer changes the formulation of raw material used;
- when cisterns of a designation (see Clause 9) not previously type tested are manufactured;
- when changes are made in the dimensions of wall thickness, height, diameter, length, width or configuration for any one cistern capacity.

Table C.1 — Type tests

Test	Requirement specified in	Test method given in
Deformation resistance	7.2	Annex D
Deflection resistance	7.3	Annex E
Fatigue resistance	7.4	Annex F
Weathering	7.10	Annex L
Hot water resistance	7.11	Annex M
Fit of cover	8.2	Annex N
Construction of cover	8.4	Annex D and Annex O
Impact resistance of cover	8.5	Annex P
Thermal insulation	10.5	Annex Q
Particle ingress limitation	10.6	Annex O

NOTE The type tests shown in Table C.1 are a complete list of individual tests not intended to be carried out in the sequence given in the table.

Type testing shall be carried out on a continuing basis to a regular schedule such as will ensure that each size and design of cistern is tested at least once in every 3-year period.

C.2 Routine testing

The tests specified in Table C.2 shall be carried out as routine tests.

At the start of a production run, tests shall be made on successive cisterns until a satisfactory cistern has been produced (i.e. one that conforms to the requirements specified in the subclauses listed in Table C.2) and thereafter the rate of test shall be 0.2 % or, if the run is less than 500 cisterns, one cistern at the end of this production run.

If any cistern so tested fails any of the routine tests listed in Table C.2, a sequence of previously and subsequently produced cisterns in that production run shall be tested until a satisfactory cistern is again identified. All cisterns produced between the two identified as satisfactory shall be rejected.

Table C.2 — Routine tests

Test	Requirement specified in	Test method given in
Impact resistance	7.5	Annex G
Tensile properties	7.6	Annex H
Resistance to reversion ^a	7.7	Annex I
Resistance to sprue strain ^a	7.8	Annex J
Resistance to delamination ^a	7.9	Annex K

^a Applicable to injection moulded cisterns only.

Annex D (normative)

Methods of test for resistance to deformation

D.1 Method 1: circular cisterns

D.1.1 The cistern shall be tested with the cover in place.

D.1.2 Place the cistern on a flat level base. Make a circumferential measurement parallel to the base and at a distance from the base of one-third the height, measured between the base and the water line.

D.1.3 Fill the cistern to the water line at a rate of not less than 23 l/min with water at (23 ± 2) °C.

D.1.4 Float a continuous film of polyethylene over the whole of the surface of the water in the cistern to prevent evaporation.

D.1.5 Maintain the temperature of the cistern and water at (23 ± 2) °C and after 10 days make a circumferential measurement at the level determined in **D.1.2**.

D.2 Method 2: non-circular cisterns

D.2.1 The cistern shall be tested with the cover in place.

D.2.2 Place the cistern on a flat level base. Measure the internal length and width of the cistern on the centrelines, as indicated in Figure D.1, at a point 100 mm above the water line. Fill the cistern to the water line at a minimum rate of 23 l/min, with water at (23 ± 2) °C.

D.2.3 Float a continuous film of polyethylene over the whole of the surface of the water in the cistern to prevent evaporation.

D.2.4 Maintain the temperature of the cistern and water at (23 ± 2) °C, and after 10 days make measurements of length and width at the centrelines determined in **D.2.2**.

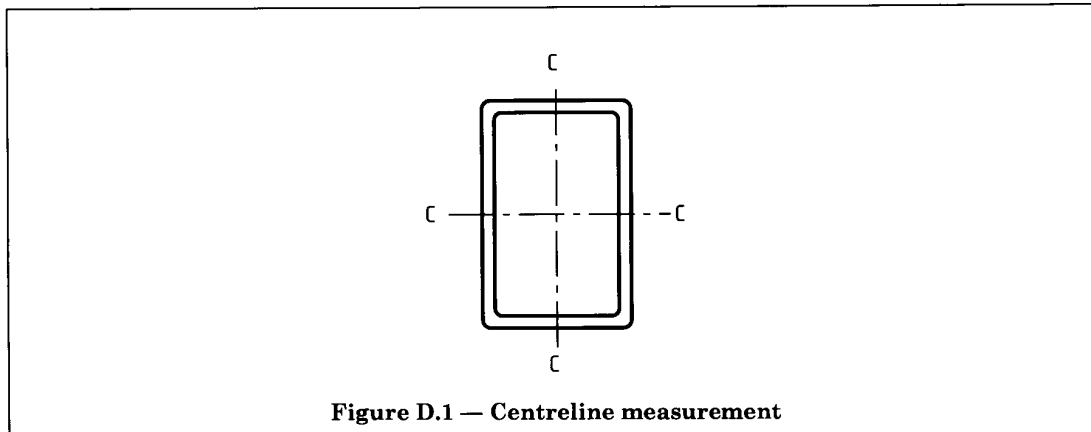

Figure D.1 — Centreline measurement

D.2.5 Calculate the percentage deformation in each direction as follows:

$$D_L = \frac{W_2 - W_1}{2L_1} \times 100$$

$$D_w = \frac{L_2 - L_1}{2W_1} \times 100$$

where:

D_L is the deformation of the longer side, as a percentage (%);

D_w is the deformation of the shorter side, as a percentage (%);

L_1 is the length at start of test, in millimetres (mm);

L_2 is the length at end of test, in millimetres (mm);

W_1 is the width at start of test, in millimetres (mm);

W_2 is the width at end of test, in millimetres (mm).

Annex E (normative)

Method of test for resistance to deflection

E.1 Apparatus

E.1.1 *Thin-walled copper tube* conforming to BS EN 1057, closed at one end, of 12.5 mm nominal bore and 305 mm length.

E.2 Procedure

E.2.1 Place the cistern on a flat level base, with the copper tube (E.1.1) attached to the wall at the inlet position as shown in Figure E.1. The centreline of the float-operated valve shall be a minimum of (60 ± 5) mm from the top of the cistern.

E.2.2 Fit any backing plate normally supplied with the cistern, then fill the cistern to the top with water at a temperature of (23 ± 2) °C.

E.2.3 Apply a force of 37 N vertically downwards at the end of the tube as shown in Figure E.1. Take a reading on the scale, after a stabilization period of 60 s.

E.2.4 Maintain the force for 1 h and take a further reading.

E.3 Calculation

Calculate the deflection as the difference between the readings taken in E.2.3 and E.2.4.

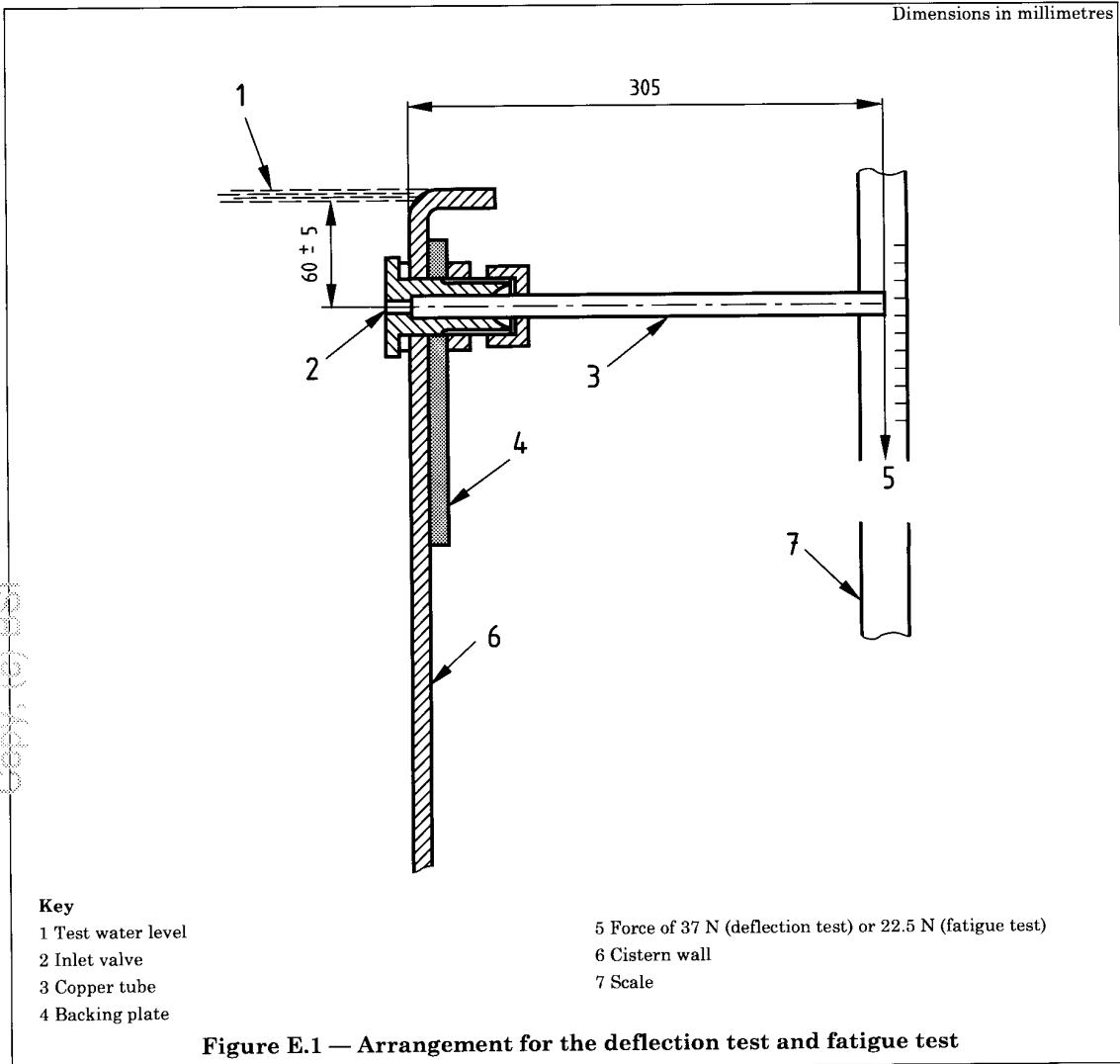

Annex F (normative)

Method of test for fatigue resistance

F.1 Apparatus

F.1.1 *Thin-walled copper tube* conforming to BS EN 1057, closed at one end, of 12.5 mm nominal bore and 305 mm length.

F.2 Procedure

F.2.1 Place the cistern on a flat level base, with the copper tube (F.1.1) attached to the wall at the inlet position as shown in Figure E.1. The centreline of the float-operated valve shall be a minimum of (60 ± 5) mm from the top of the cistern.

F.2.2 Fit any backing plate normally supplied with the cistern, and then fill the cistern to the water line with water at a temperature of (23 ± 2) °C.

F.2.3 Apply a force of 22.5 N vertically downwards to the end of the tube, and allow the tube to move from its normal unloaded position to that taken up when under the applied load.

F.2.4 Resonate the end of the tube under this load in the vertical axis of the cistern at a rate of not less than 10 cycles/min for a total of 100 000 cycles.

Annex G (normative)

Method of test for impact resistance

G.1 Invert the cistern and maintain it at a temperature of (23 ± 2) °C for a period of not less than 1 h prior to the commencement of the test.

G.2 Strike the cistern four times with a 25 mm diameter hemispherical-ended striker of mass 2.5 kg falling freely from a height of 3 m. Make the impacts using either one of the following two procedures, as appropriate to the type of cistern.

- a) For cisterns that have a moulding with a sprue in the centre of the base, arrange the striker so as to hit the base at this point. Make three additional impacts as close to the edge or corners of the base as is practical.
- b) For cisterns that are injection-moulded with multipoint tools, arrange the four strikes so that they impact different sprue areas in turn. The shape of the striker shall be such that only the surface of the specified hemisphere comes into contact with the cistern under the initial blow.

Annex H (normative)

Method of test for tensile strength and elongation at break

H.1 Carry out the test in accordance with BS EN ISO 527-1, except for the following.

- a) The thickness of the specimens shall be that of the cistern wall. An equal number of specimens shall be taken from the horizontal and vertical axes of the cistern wall, but where the design only permits specimens to be taken in the vertical axis, an equal number of specimens shall be taken from the cistern base.
- b) The specimens shall be either punched from the cistern wall at a temperature not in excess of 50 °C, or machined or routed from the cistern wall. When routed or machined, the edges of the specimens shall be polished to ensure the absence of notches.
- c) The rate of separation of the grips shall be:
 - 1) (500 ± 50) mm/min, for polyethylene with a derived density from 0.910 g/cm³ to 0.925 g/m³;
 - 2) (100 ± 10) mm/min, for polyethylene with a derived density greater than 0.925 g/m³, and for polypropylene.

H.2 In the case of a cistern having composite walls, carry out the test on specimens moulded from polyolefin compound identical to that used in the manufacture of the cistern.

Annex I (normative)**Method of test for resistance to reversion**

I.1 Cut or punch five specimens, 50 mm long and with a diameter of 2.5 mm, from the cistern in each of the following positions:

- a) one-third of the height of the side wall, such that their main axes are parallel relative to the direction of flow during cistern fabrication;
- b) two-thirds of the height of the side wall, such that their main axes are parallel relative to the direction of flow during cistern fabrication;
- c) the base, such that they are taken radially with their centre points 76 mm from the sprue.

I.2 Record the initial lengths of the individual specimens.

I.3 Test the specimens under the conditions specified in Table I.1 for the relevant material.

Table I.1 — Testing conditions for reversion and sprue strain

Material	Density g/cm ³	Temperature °C	Heating medium	Period of test min
Polyethylene	<0.94	100	Water	30
Polyethylene	>0.94	110	Talcum powder or glycerol	30
Polypropylene	—	140	Talcum powder or glycerol	30

I.4 On removal, allow the specimens to cool to room temperature for a period of 1 h, and then measure their length.

I.5 Express the reversion as the percentage reduction in length of the specimens.

Annex J (normative)**Method of test for resistance to sprue strain**

J.1 The specimen shall consist of a 75 mm diameter disc, with the sprue at the centre, cut from the base of the cistern.

J.2 Make a slit in the specimen (38 ± 1.5) mm long, such that its mid-point lies on the centre of the specimen and extends through its thickness.

NOTE This slit can be conveniently made with a single-edge razor blade.

J.3 Test the specimens under the conditions specified in Table I.1 for the relevant material.

J.4 On removal, allow the specimens to cool with no applied constraint.

J.5 Measure and record the maximum distance between the edges of the slit.

Annex K (normative)**Method of test for resistance to delamination**

K.1 Cut or punch four specimens, 50 mm long and with a diameter of 2.5 mm, from the base of the cistern such that they are taken radially, with their centre points 76 mm from the sprue.

K.2 Immerse the specimens in the relevant medium given in Table K.1 for a period of 4 h at (50 ± 0.5) °C. After removal, allow the specimens to dry in air for 1 h.

Table K.1 — Immersion media

Material	Medium
Polyethylene	Carbon tetrachloride
Polypropylene	1,2,3,4-tetrahydronaphthalene (tetralin)

K.3 Examine the extent of delamination in the polyolefin and compare it with the examples given in Table 2.

Annex L (normative)**Method of test for weathering****L.1 Apparatus**

L.1.1 *Weathering apparatus* conforming to BS EN ISO 4892-2. The light source shall be a xenon arc lamp (6 500 W) which is changed every 2 000 h. A cycle of 18 min of water spray in every 2 h period shall be used.

NOTE 1 The lamp assembly should incorporate borosilicate glass filters. The inner filters in this lamp assembly should be changed every 400 h and the outer filters every 2 000 h.

NOTE 2 The temperature in the cabinet should be controlled so that the temperature recorded on a black panel thermometer mounted in the same manner and position as the exposed specimens is (55 ± 3) °C. The humidity levels should be controlled at (65 ± 5) % relative humidity during the periods when the water spray is not in operation.

L.1.2 *Cylindrical rack*, which revolves around the light source at a speed of 1 r/min.

L.2 Procedure

L.2.1 Take two sets of two test specimens from the cistern as described in Annex H, i.e. four sets in total if both vertical and horizontal walls have been sampled.

L.2.2 Mount the specimens on the cylindrical rack, 457 mm from the central vertical axis of the light source.

L.2.3 For each set of specimens, test half the set in accordance with Annex H after they have been exposed in the weathering apparatus for a period of 1 200 h, and retain the other half for testing similarly in accordance with Annex H to provide data on unweathered and weathered material.

Annex M (normative)**Method of test for hot water resistance****M.1 Apparatus**

The test installation shall be as shown in Figure M.1 and Figure M.2 (see Note 1) and shall be in a controlled environment where the air temperature at the cistern water level, 100 mm from the side of the cistern, is (38 ± 3) °C.

NOTE 1 The actual positions of the connections to the cisterns may be varied slightly from those indicated in Figure M.1 and Figure M.2 in order to accommodate design features of the cisterns.

The connections to the cistern shall be 22 mm in diameter and shall be supported by a flange/plate with a support area of not less than 1 900 mm².

The heat input shall be provided by a 3 kW heater conforming to BS EN 60335-2-73, of 760 mm length. No thermostat or cut-off device shall be provided, in order that runaway conditions can prevail.

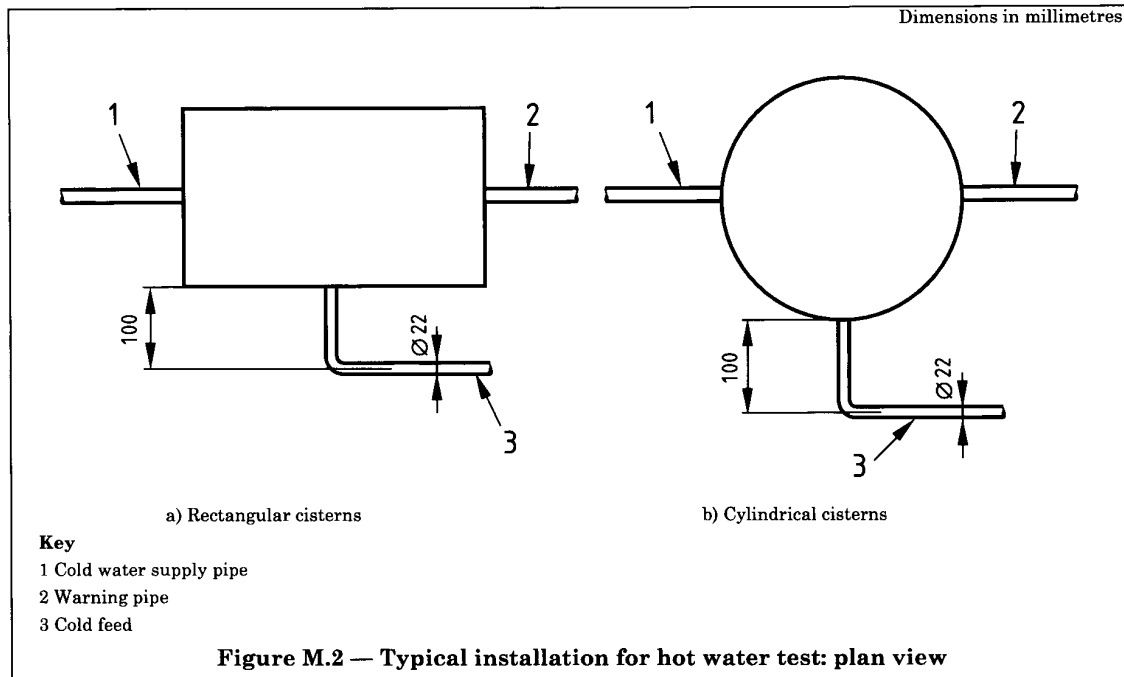

M.2 Procedure

M.2.1 Install the cistern in accordance with the manufacturer's instructions. Do not apply any insulation to the cistern or any of the pipework. If insulation has already been applied to the cistern, remove it carefully.

NOTE All pipework should be supported in accordance with good plumbing practice and with the cistern manufacturer's instructions.

M.2.2 Fill the installation with cold water to the water line and switch on the heater for a continuous period of $(500 \pm 1)_0^1$ h.

M.2.3 At the end of this time switch off the heater and allow a period of not less than $(120 \pm 15)_0^{15}$ h to elapse to permit cooling of the installation.

Annex N (normative)

Method of test for closeness of cover fitting

N.1 Apparatus

NOTE A typical arrangement of the apparatus is shown in Figure N.1.

N.1.1 *Single pulley*, capable of being supported above the cistern cover to apply the required force.

N.1.2 *Cord*, capable of supporting the applied force.

N.1.3 *Weights*, sufficient to apply the necessary force required to remove the lid of the cistern via the cord.

NOTE The weight normally has a mass of 6 kg for each square metre of cover horizontal area, or 1.5 times the cover weight, whichever is the greater.

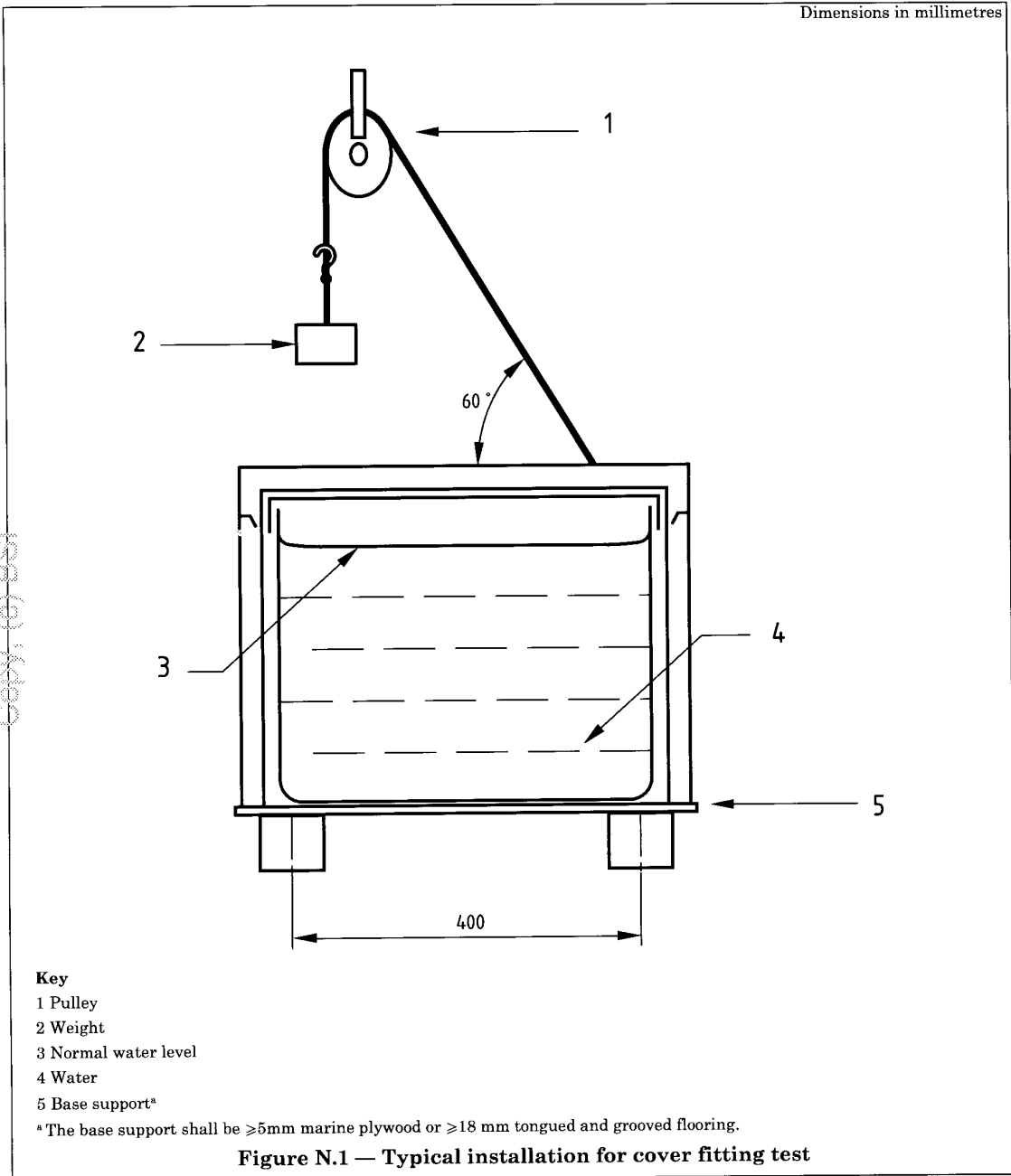

N.2 Procedure

N.2.1 Fill the cistern with water to the water line and fit the cover as recommended by the manufacturer.

N.2.2 Position a free-running pulley (N.1.1) at a height that enables a cord (N.1.2) passing over the pulley to make an angle of 60° with the horizontal, and to be remote from the edges of the cover.

N.2.3 Apply a weight (N.1.3) to the other end of the cord, for a period of 30 s.

N.2.4 For rectangular cisterns, repeat the test on all four sides in the direction of each side of a rectangular cistern. For circular cisterns, apply the test in four directions progressively, each at 90° to the previous position. Observe whether the cover is detached during the test.

Annex O (normative)

Method of test for the assessment of ingress of particles

O.1 Apparatus

NOTE A typical installation is shown in Figure O.1.

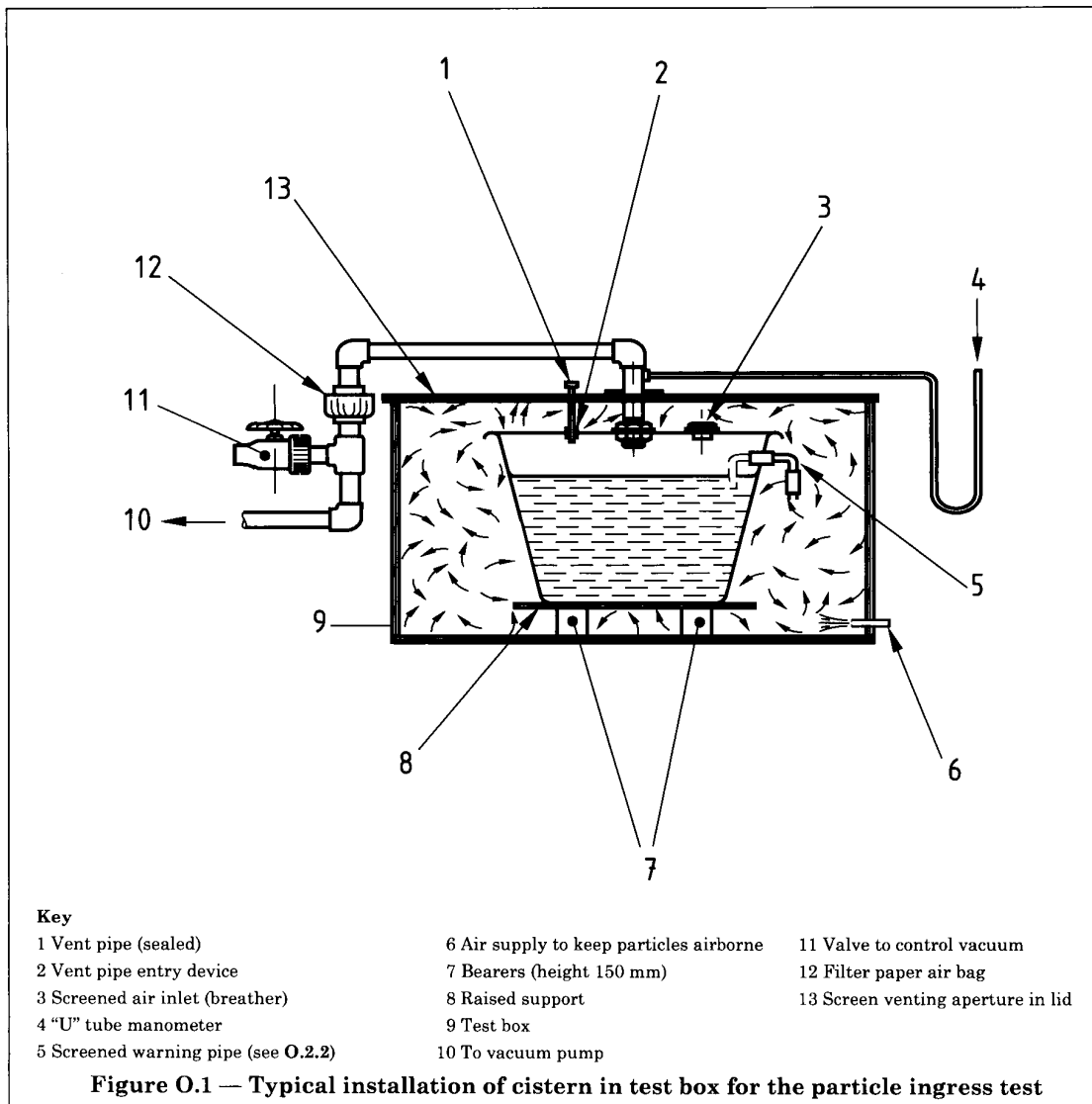

O.1.1 Test box, with a removable cover fitted with an inlet to allow entry of an air line and with a connection for the vacuum pump at the top. The test box dimensions shall be such that there is a gap of at least 150 mm between the box and the cistern to permit a free flow of air when installed.

O.1.2 Polyethylene particles measuring 0.5 mm to 1.00 mm.

O.1.3 Vacuum pump and connection fitted with a filter paper or other bag capable of retaining the polyethylene particles. The vacuum pump shall be capable of maintaining a partial vacuum of (50 ± 10) mm water gauge. A relief valve vented to atmosphere shall be fitted for control of vacuum.

O.1.4 U-tube manometer to measure partial vacuum applied to the cistern.

O.2 Procedure

O.2.1 Remove the cover from the test box.

O.2.2 Install the cistern, cover and fittings to be evaluated in the test box (**O.1.1**) and place the cistern on the raised support base. (When testing an additional fitting kit, the screened breather, vent pipe entry device and warning pipe termination assembly shall be tested on one size of the cistern and cover only.) Remove the turn-down on the warning pipe or adjust it so that it is not below the water level. Seal the vent pipe.

O.2.3 Partly fill the test box with polyethylene particles (**O.1.2**) to a height not less than 75 mm above the base.

O.2.4 Fill the cistern with water at a temperature of (20 ± 5) °C to the water line and fit the cover to the cistern in accordance with the manufacturer's instructions.

O.2.5 Replace the cover on the test box and ensure that it is airtight.

O.2.6 Activate the air supply so that the particles remain airborne.

O.2.7 Activate the vacuum pump (**O.1.3**) leaving the relief valve fully open to atmosphere. Gradually close the relief valve until the manometer (**O.1.4**) indicates that a partial vacuum of (50 ± 10) mm water gauge is being applied to the cistern. Maintain this partial vacuum for $5 \text{ min} \pm 10 \text{ s}$.

O.2.8 At the end of the test, shut off the equipment, examine the filter paper or bag in the vacuum pump line and measure any particles found.

Annex P (normative)

Method of test for determining the impact resistance of covers

P.1 Support the cover on a cistern of the appropriate dimensions and maintain it at a temperature of (23 ± 2) °C for a period of not less than 1 h prior to the commencement of the test.

P.2 Strike the cover with a 25 mm diameter hemispherical-ended striker of mass 2.5 kg falling freely from a height of 0.5 m. The shape of the striker shall be such that only the surface of the specimen hemisphere comes into contact with the cover under the initial blow. Arrange the striker so that it hits the cover at its midpoint. Make three other impacts as close to the edge or corners as is practical.

Annex Q (normative)

Method of test for thermal insulation

Q.1 General

The test shall be conducted within a room or other enclosed area equipped with facilities to maintain a constant ambient temperature ± 2 °C between 10 °C and 25 °C and to monitor ambient temperature throughout the test period.

All thermometer and sensor readings shall be recorded to an accuracy of 0.5 °C.

Q.2 Apparatus

NOTE A typical installation is shown in Figure Q.1.

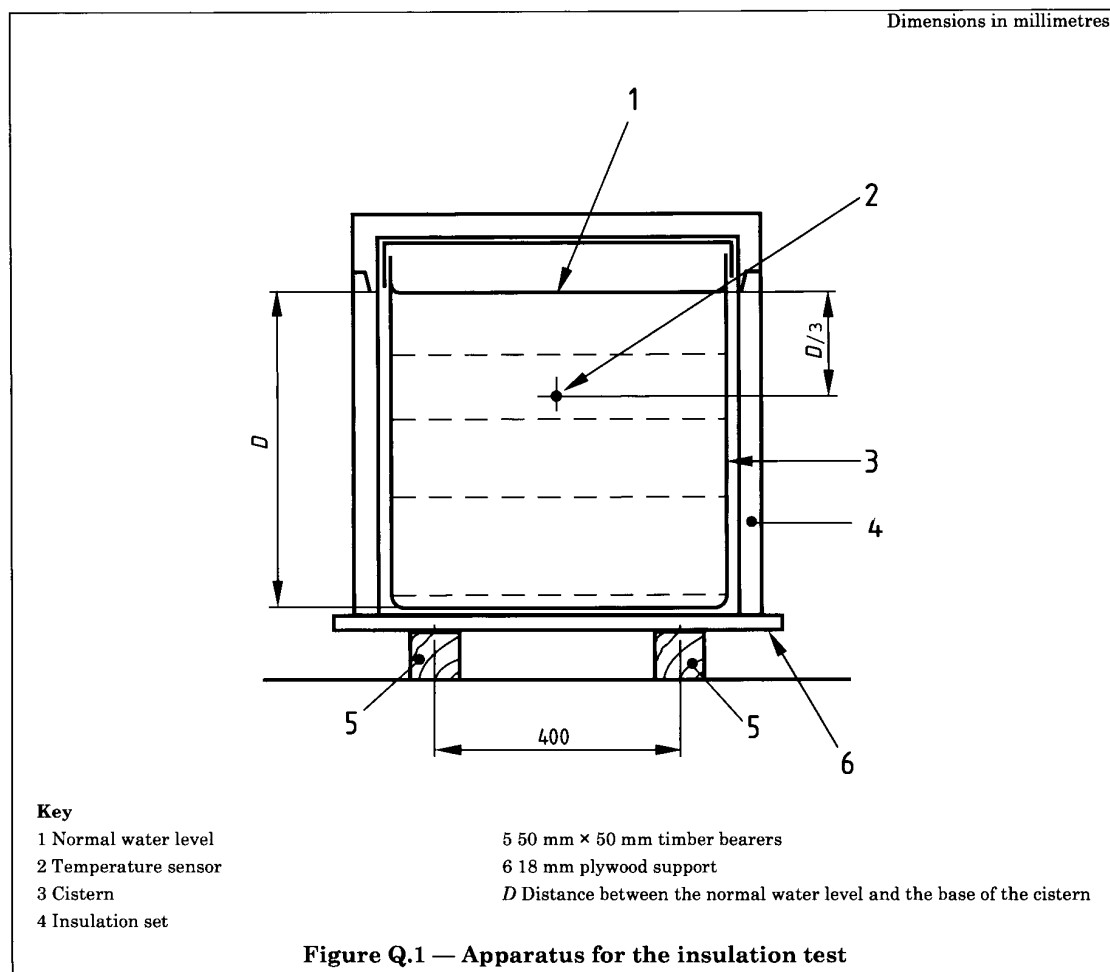

Q.2.1 25.1 gallon (114 l) capacity cistern (or the next largest in the manufacturer's range), together with an insulation set of the relevant size.

Q.2.2 Test bed comprising a sheet of 18 mm plywood, at least as large as the plan area of the insulation set to be tested, mounted on transverse 50 mm × 50 mm timber bearers at 400 mm centres.

Q.2.3 Vent pipe to discharge 100 mm from the sides of the cistern but not over the float-operated valve or float.

Q.3 Procedure

Q.3.1 Arrange the cistern, excluding the cover, on the test bed.

Q.3.2 Fit the insulation in accordance with the manufacturer's instructions but without the top insulation.

Q.3.3 If a lid is fitted, cut a hole to prevent any discharge from the vent pipe from entering the cistern.

Q.3.4 Position the temperature sensor, using the stand and/or fixings, at the centre of the cistern plan area at a depth below the normal water level at one-third of the distance between the normal water level and the base of the cistern (see *D* in Figure Q.1).

Q.3.5 Record the ambient room temperature, which shall be between 10 °C and 25 °C (see Q.1). If the thermometer is not of the constant recording type, re-record the ambient temperature at the commencement of the test period and at (60 ± 10) min intervals throughout the test period.

NOTE In determining the ambient temperature to be applied, the characteristics and properties of the cistern material should be taken into account.

Q.3.6 Fill the cistern to the normal water level with water at a temperature not less than (25 ± 0.5) °C above the recorded ambient temperature.

Q.3.7 Leave the apparatus to stand with agitation at the beginning, middle and end of the test, until the sensor registers (20 ± 0.5) °C above the recorded ambient temperature.

Q.3.8 Fit the cistern cover and top insulation.

Q.3.9 Commence the test period.

Q.3.10 After a period of $18 \text{ h} \pm 15 \text{ min}$, remove the top insulation and cistern cover and record the sensor reading.

~ Bibliography

Standards publications

BS 1212-2:1990, *Float operated valves — Part 2: Specification for diaphragm type float operated valves (copper alloy body) (excluding floats)*.

BS 1968:1953, *Specification for floats for ballvalves (copper)*.

Other publications

- [1] GREAT BRITAIN. Water Supply (Water Quality) Regulations 2001. London: The Stationery Office.
- [2] GREAT BRITAIN. Water Supply (Water Quality) (Scotland) Regulations 2001. London: The Stationery Office.³⁾
- [3] GREAT BRITAIN. Water Supply (Water Quality) Regulations (Northern Ireland) 2002. London: The Stationery Office.⁴⁾
- [4] EUROPEAN COMMUNITIES. 98/83/EC. Council Directive on the quality of water intended for human consumption. Luxembourg: Office for Official Publications of the European Communities, 1998.

³⁾ As amended by the Water Supply (Water Quality) (Scotland) Amendment Regulations 2001.

⁴⁾ As amended by the Water Supply (Water Quality) (Amendment) Regulations (Northern Ireland) 2003.

BSI — British Standards Institution

BSI is the independent national body responsible for preparing British Standards. It presents the UK view on standards in Europe and at the international level. It is incorporated by Royal Charter.

Revisions

British Standards are updated by amendment or revision. Users of British Standards should make sure that they possess the latest amendments or editions.

It is the constant aim of BSI to improve the quality of our products and services. We would be grateful if anyone finding an inaccuracy or ambiguity while using this British Standard would inform the Secretary of the technical committee responsible, the identity of which can be found on the inside front cover. Tel: +44 (0)20 8996 9000. Fax: +44 (0)20 8996 7400.

BSI offers members an individual updating service called PLUS which ensures that subscribers automatically receive the latest editions of standards.

Buying standards

Orders for all BSI, international and foreign standards publications should be addressed to Customer Services. Tel: +44 (0)20 8996 9001. Fax: +44 (0)20 8996 7001. Email: orders@bsi-global.com. Standards are also available from the BSI website at <http://www.bsi-global.com>.

In response to orders for international standards, it is BSI policy to supply the BSI implementation of those that have been published as British Standards, unless otherwise requested.

Information on standards

BSI provides a wide range of information on national, European and international standards through its Library and its Technical Help to Exporters Service. Various BSI electronic information services are also available which give details on all its products and services. Contact the Information Centre. Tel: +44 (0)20 8996 7111. Fax: +44 (0)20 8996 7048. Email: info@bsi-global.com.

Subscribing members of BSI are kept up to date with standards developments and receive substantial discounts on the purchase price of standards. For details of these and other benefits contact Membership Administration. Tel: +44 (0)20 8996 7002. Fax: +44 (0)20 8996 7001. Email: membership@bsi-global.com.

Information regarding online access to British Standards via British Standards Online can be found at <http://www.bsi-global.com/bsonline>.

Further information about BSI is available on the BSI website at <http://www.bsi-global.com>.

Copyright

Copyright subsists in all BSI publications. BSI also holds the copyright, in the UK, of the publications of the international standardization bodies. Except as permitted under the Copyright, Designs and Patents Act 1988 no extract may be reproduced, stored in a retrieval system or transmitted in any form or by any means – electronic, photocopying, recording or otherwise – without prior written permission from BSI.

This does not preclude the free use, in the course of implementing the standard, of necessary details such as symbols, and size, type or grade designations. If these details are to be used for any other purpose than implementation then the prior written permission of BSI must be obtained.

Details and advice can be obtained from the Copyright & Licensing Manager. Tel: +44 (0)20 8996 7070. Fax: +44 (0)20 8996 7553. Email: copyright@bsi-global.com.

BSI
389 Chiswick High Road
London
W4 4AL

Draft for comments only — Not to be cited as East African Standard