



## **EAST AFRICAN STANDARD**

---

**Plastics piping systems for water supply and for buried and above-ground drainage and sewerage under pressure — Unplasticized poly(vinyl chloride) (PVC-U) — Part 2: Pipes**

**EAST AFRICAN COMMUNITY**

---

## Foreword

Development of the East African Standards has been necessitated by the need for harmonizing requirements governing quality of products and services in East Africa. It is envisaged that through harmonized standardization, trade barriers which are encountered when goods and services are exchanged within the Community will be removed.

In order to meet the above objectives, the EAC Partner States have enacted an East African Standardization, Quality Assurance, Metrology and Test Act, 2006 (EAC SQMT Act, 2006) to make provisions for ensuring standardization, quality assurance, metrology and testing of products produced or originating in a third country and traded in the Community in order to facilitate industrial development and trade as well as helping to protect the health and safety of society and the environment in the Community.

East African Standards are formulated in accordance with the procedures established by the East African Standards Committee. The East African Standards Committee is established under the provisions of Article 4 of the EAC SQMT Act, 2006. The Committee is composed of representatives of the National Standards Bodies in Partner States, together with the representatives from the private sectors and consumer organizations. Draft East African Standards are circulated to stakeholders through the National Standards Bodies in the Partner States. The comments received are discussed and incorporated before finalization of standards, in accordance with the procedures of the Community.

Article 15(1) of the EAC SQMT Act, 2006 provides that "Within six months of the declaration of an East African Standard, the Partner States shall adopt, without deviation from the approved text of the standard, the East African Standard as a national standard and withdraw any existing national standard with similar scope and purpose".

East African Standards are subject to review, to keep pace with technological advances. Users of the East African Standards are therefore expected to ensure that they always have the latest versions of the standards they are implementing.

© East African Community 2010 — All rights reserved\*

East African Community

P O Box 1096

**Arusha**

Tanzania

Tel: 255 27 2504253/8

Fax: 255-27-2504481/2504255

E-Mail: [eac@eachq.org](mailto:eac@eachq.org)

Web: [www.each.int](http://www.each.int)

## Introduction

In the preparation of this East African Standard, the following source was consulted extensively:

ISO 1452-2:2009, *Plastics piping systems for water supply and for buried and above-ground drainage and sewerage under pressure — Unplasticized poly(vinyl chloride) (PVC-U) — Part 2: Pipes*

Assistance derived from this source and others inadvertently not mentioned is hereby acknowledged.

Draft for comments only — Not to be cited as East African Standard

---

---

**Plastics piping systems for water supply  
and for buried and above-ground  
drainage and sewerage under pressure —  
Unplasticized poly(vinyl chloride)  
(PVC-U) —**

**Part 2:  
Pipes**

*Systèmes de canalisations en plastique pour l'alimentation en eau, pour  
branchements et collecteurs d'assainissement enterrés et aériens avec  
pression — Poly(chlorure de vinyle) non plastifié (PVC-U) —*

*Partie 2: Tubes*



**PDF disclaimer**

This PDF file may contain embedded typefaces. In accordance with Adobe's licensing policy, this file may be printed or viewed but shall not be edited unless the typefaces which are embedded are licensed to and installed on the computer performing the editing. In downloading this file, parties accept therein the responsibility of not infringing Adobe's licensing policy. The ISO Central Secretariat accepts no liability in this area.

Adobe is a trademark of Adobe Systems Incorporated.

Details of the software products used to create this PDF file can be found in the General Info relative to the file; the PDF-creation parameters were optimized for printing. Every care has been taken to ensure that the file is suitable for use by ISO member bodies. In the unlikely event that a problem relating to it is found, please inform the Central Secretariat at the address given below.



**COPYRIGHT PROTECTED DOCUMENT**

© ISO 2009

All rights reserved. Unless otherwise specified, no part of this publication may be reproduced or utilized in any form or by any means, electronic or mechanical, including photocopying and microfilm, without permission in writing from either ISO at the address below or ISO's member body in the country of the requester.

ISO copyright office  
Case postale 56 • CH-1211 Geneva 20  
Tel. + 41 22 749 01 11  
Fax + 41 22 749 09 47  
E-mail [copyright@iso.org](mailto:copyright@iso.org)  
Web [www.iso.org](http://www.iso.org)

Published in Switzerland

# Contents

Page

Foreword .....	iv
Introduction.....	v
<b>1 Scope .....</b>	<b>1</b>
<b>2 Normative references .....</b>	<b>1</b>
<b>3 Terms, definitions, symbols and abbreviated terms .....</b>	<b>2</b>
<b>4 Material .....</b>	<b>3</b>
4.1 Pipe material .....	3
4.2 Density .....	3
4.3 MRS-value .....	3
<b>5 General characteristics .....</b>	<b>3</b>
5.1 Appearance .....	3
5.2 Colour .....	3
5.3 Opacity of pipes intended for the above-ground conveyance of water .....	3
<b>6 Geometrical characteristics .....</b>	<b>3</b>
6.1 Measurement of dimensions .....	3
6.2 Nominal outside diameters.....	3
6.3 Mean outside diameters and their tolerances .....	4
6.4 Wall thickness and their tolerances .....	5
6.5 Length of pipe.....	6
6.6 Pipes with sockets .....	7
6.7 Pipe ends for ring seal or solvent cement joints .....	11
<b>7 Classification and selection of pipes .....</b>	<b>11</b>
7.1 Classification .....	11
7.2 Selection of nominal pressure and pipe series S for water up to and including 25 °C .....	11
7.3 Determination of the allowable operating pressure for water up to 45 °C .....	11
<b>8 Mechanical characteristics.....</b>	<b>11</b>
8.1 Impact strength.....	11
8.2 Resistance to internal pressure.....	12
<b>9 Physical characteristics.....</b>	<b>13</b>
<b>10 Sealing rings .....</b>	<b>14</b>
<b>11 Adhesives.....</b>	<b>14</b>
<b>12 Performance requirements.....</b>	<b>14</b>
<b>13 Marking .....</b>	<b>14</b>
13.1 General .....	14
13.2 Minimum required marking .....	14
13.3 Additional marking .....	15
<b>Annex A (normative) Allowable operating pressures .....</b>	<b>16</b>
<b>Annex B (normative) Imperial (inch)-sized pipes .....</b>	<b>18</b>
<b>Bibliography.....</b>	<b>23</b>

## Foreword

ISO (the International Organization for Standardization) is a worldwide federation of national standards bodies (ISO member bodies). The work of preparing International Standards is normally carried out through ISO technical committees. Each member body interested in a subject for which a technical committee has been established has the right to be represented on that committee. International organizations, governmental and non-governmental, in liaison with ISO, also take part in the work. ISO collaborates closely with the International Electrotechnical Commission (IEC) on all matters of electrotechnical standardization.

International Standards are drafted in accordance with the rules given in the ISO/IEC Directives, Part 2.

The main task of technical committees is to prepare International Standards. Draft International Standards adopted by the technical committees are circulated to the member bodies for voting. Publication as an International Standard requires approval by at least 75 % of the member bodies casting a vote.

Attention is drawn to the possibility that some of the elements of this document may be the subject of patent rights. ISO shall not be held responsible for identifying any or all such patent rights.

ISO 1452-2 was prepared by the European Committee for Standardization (CEN) Technical Committee CEN/TC 155, *Plastics piping systems and ducting systems*, in collaboration with ISO Technical Committee ISO/TC 138, *Plastics pipes, fittings and valves for the transport of fluids*, Subcommittee SC 2, *Plastics pipes and fittings for water supplies*, in accordance with the Agreement on technical cooperation between ISO and CEN (Vienna Agreement).

This first edition cancels and replaces ISO 4422-2:1996 and ISO 2045, which have been technically revised.

ISO 1452 consists of the following parts, under the general title *Plastics piping systems for water supply and for buried and above-ground drainage and sewerage under pressure — Unplasticized poly(vinyl chloride) (PVC-U)*:

- *Part 1: General*
- *Part 2: Pipes*
- *Part 3: Fittings*
- *Part 4: Valves*
- *Part 5: Fitness for purpose of the system*

Guidance for the assessment of conformity is to form the subject of a part 7.

## Introduction

The System Standard, of which this is Part 2, specifies the requirements for a piping system and its components made from unplasticized poly(vinyl chloride) (PVC-U). The piping system is intended to be used for water supply and for buried and above-ground drainage and sewerage under pressure.

In respect of potential adverse effects on the quality of water intended for human consumption, caused by the products covered by this part of ISO 1452, the following are relevant.

- a) This part of ISO 1452 provides no information as to whether or not the products can be used without restriction.
- b) Existing national regulations concerning the use and/or the characteristics of these products remain in force.

Requirements and test methods for material and components, other than pipes, are specified in ISO 1452-1, ISO 1452-3 and ISO 1452-4. Characteristics for fitness for purpose (mainly for joints) are established in ISO 1452-5.

This part of ISO 1452 specifies the characteristics of pipes.

Guidance for installation is given in ISO/TR 4191<sup>[1]</sup>.

Guidance for assessment of conformity is provided in ENV 1452-7<sup>[2]</sup>.

*Draft for comments only — Not to be cited as East African Standard*

# Plastics piping systems for water supply and for buried and above-ground drainage and sewerage under pressure — Unplasticized poly(vinyl chloride) (PVC-U) —

## Part 2: Pipes

### 1 Scope

This part of ISO 1452 specifies the characteristics of solid-wall pipes made from unplasticized poly(vinyl chloride) (PVC-U) for piping systems intended for water supply and for buried and above-ground drainage and sewerage under pressure.

It also specifies the test parameters for the test methods referred to in this part of ISO 1452.

In conjunction with ISO 1452-1 and ISO 1452-5, it is applicable to extruded PVC-U pipes without a socket and pipes with a socket (integral or not), intended to be used for the following:

- a) water mains and services buried in the ground;
- b) conveyance of water above ground for both outside and inside buildings;
- c) buried and above-ground drainage and sewerage under pressure.

It is applicable to piping systems intended for the supply of water under pressure up to and including 25 °C (cold water) intended for human consumption and for general purposes as well as for waste water under pressure.

This part of ISO 1452 specifies pipes for the conveyance of water and waste water up to and including 45 °C. For temperatures between 25 °C and 45 °C, Figure A.1 applies.

NOTE 1 The producer and the end-user can come to agreement on the possibilities of use for temperatures above 45 °C on a case-by-case basis.

This part of ISO 1452 specifies a range of pipe sizes and pressure classes, and gives requirements concerning colours.

NOTE 2 It is the responsibility of the purchaser or specifier to make the appropriate selections from these aspects, taking into account their particular requirements and any relevant national regulations and installation practices or codes.

### 2 Normative references

The following referenced documents are indispensable for the application of this document. For dated references, only the edition cited applies. For undated references, the latest edition of the referenced document (including any amendments) applies.

ISO 1167-1, *Thermoplastics pipes, fittings and assemblies for the conveyance of fluids — Determination of the resistance to internal pressure — Part 1: General method*

ISO 1167-2, *Thermoplastics pipes, fittings and assemblies for the conveyance of fluids — Determination of the resistance to internal pressure — Part 2: Preparation of pipe test pieces*

ISO 1183-1:2004, *Plastics — Methods for determining the density of non-cellular plastics — Part 1: Immersion method, liquid pycnometer method and titration method*

ISO 1452-1:2009, *Plastics piping systems for water supply and for buried and above-ground drainage and sewerage under pressure — Unplasticized poly(vinyl chloride) (PVC U) — Part 1: General*

ISO 1452-5, *Plastics piping systems for water supply and for buried and above-ground drainage and sewerage under pressure — Unplasticized poly(vinyl chloride) (PVC U) — Part 5: Fitness for purpose of the system*

ISO 2505, *Thermoplastics pipes — Longitudinal reversion — Test method and parameters*

ISO 2507-1:1995, *Thermoplastics pipes and fittings — Vicat softening temperature — Part 1: General test method*

ISO 3126, *Plastics piping systems — Plastics components — Determination of dimensions*

ISO 6259-1, *Thermoplastics pipes — Determination of tensile properties — Part 1: General test method*

ISO 6259-2, *Thermoplastics pipes — Determination of tensile properties — Part 2: Pipes made of unplasticized poly(vinyl chloride) (PVC-U), chlorinated poly(vinyl chloride) (PVC-C) and high-impact poly(vinyl chloride) (PVC-HI)*

ISO 7387-1, *Adhesives with solvents for assembly of PVC-U pipe elements — Characterization — Part 1: Basic test methods*

ISO 7686, *Plastics pipes and fittings — Determination of opacity*

ISO 9311-1, *Adhesives for thermoplastic piping systems — Part 1: Determination of film properties*

ISO 9852, *Unplasticized poly(vinyl chloride) (PVC-U) pipes — Dichloromethane resistance at specified temperature (DCMT) — Test method*

ISO 18373-1, *Rigid PVC pipes — Differential scanning calorimetry (DSC) method — Part 1: Measurement of the processing temperature*

EN 681-1:1996, *Elastomeric seals — Materials requirements for pipe joint seals used in water and drainage applications — Part 1: Vulcanized rubber*

EN 744:1995, *Plastics piping and ducting systems — Thermoplastics pipes — Test method for resistance to external blows by the round-the-clock method*

### 3 Terms, definitions, symbols and abbreviated terms

For the purposes of this document, the terms, definitions, symbols and abbreviated terms given in ISO 1452-1 and the following apply:

- L* length of socket
- m* depth of engagement

## 4 Material

### 4.1 Pipe material

The material to be used shall conform to ISO 1452-1 and to the requirements given in 4.2 and 4.3.

### 4.2 Density

The density,  $\rho$ , at 23 °C of the pipe, when measured in accordance with ISO 1183-1, shall be within the following limits:

$$1\,350 \text{ kg/m}^3 \leq \rho \leq 1\,460 \text{ kg/m}^3$$

### 4.3 MRS-value

The pipe material shall have a minimum required strength, MRS, as defined in ISO 1452-1:2009, 4.4.1, of at least 25 MPa.

The manufacturer of the compound or formulation shall confirm the MRS by testing as described in ISO 1452-1:2009, 4.4.1 or 4.4.2, respectively.

## 5 General characteristics

### 5.1 Appearance

When viewed without magnification the internal and external surfaces of pipes shall be smooth, clean and free from scoring, cavities and other surface defects to an extent that would prevent conformity to this part of ISO 1452. The material shall not contain any impurities visible without magnification. The ends of the pipe shall be cut cleanly and square to the axis of the pipe.

### 5.2 Colour

The colour of the pipes shall be either grey, blue or cream for water supply, and grey or brown for drainage and sewerage under pressure. The colour of the pipes shall be uniform throughout the wall.

NOTE Attention is drawn to the fact that the colouring of pipes for the supply of water for human consumption can be part of national regulation.

### 5.3 Opacity of pipes intended for the above-ground conveyance of water

The wall of the pipe shall be opaque and shall not transmit more than 0,2 % of visible light when measured in accordance with ISO 7686.

## 6 Geometrical characteristics

### 6.1 Measurement of dimensions

Dimensions shall be measured in accordance with ISO 3126.

### 6.2 Nominal outside diameters

The nominal outside diameter,  $d_n$ , of a pipe shall conform to Table 1.

6.3 Mean outside diameters and their tolerances

The mean outside diameter,  $d_{em}$ , of a pipe shall conform to the applicable nominal outside diameter,  $d_n$ , within the tolerance given in Table 1.

The tolerance for out-of-roundness shall conform to Table 1.

Table 1 — Nominal outside diameters and tolerances

Dimensions in millimetres

Nominal outside diameter $d_n$	Tolerance for mean outside diameter, $d_{em}$ <sup>a</sup> $x$	Tolerance for out-of-roundness <sup>b</sup>	
		S 20 to S 16 <sup>c</sup>	S 12,5 to S 5 <sup>d</sup>
12	0,2	—	0,5
16	0,2	—	0,5
20	0,2	—	0,5
25	0,2	—	0,5
32	0,2	—	0,5
40	0,2	1,4	0,5
50	0,2	1,4	0,6
63	0,3	1,5	0,8
75	0,3	1,6	0,9
90	0,3	1,8	1,1
110	0,4	2,2	1,4
125	0,4	2,5	1,5
140	0,5	2,8	1,7
160	0,5	3,2	2,0
180	0,6	3,6	2,2
200	0,6	4,0	2,4
225	0,7	4,5	2,7
250	0,8	5,0	3,0
280	0,9	6,8	3,4
315	1,0	7,6	3,8
355	1,1	8,6	4,3
400	1,2	9,6	4,8
450	1,4	10,8	5,4
500	1,5	12,0	6,0
560	1,7	13,5	6,8
630	1,9	15,2	7,6
710	2,0	17,1	8,6
800	2,0	19,2	9,6
900	2,0	21,6	—
1 000	2,0	24,0	—

<sup>a</sup> The tolerance conforms to grade D of ISO 11922-1<sup>[3]</sup> for  $d_n \leq 50$  and to grade C for  $d_n > 50$ . The tolerance is expressed in the form  $^{+x}_0$  mm, where  $x$  is the value of the tolerance.

<sup>b</sup> The tolerance is expressed as the difference between the largest and the smallest outside diameter in a cross-section of the pipe (i.e.  $d_{e, max} - d_{e, min}$ ).

<sup>c</sup> For  $d_n \leq 250$ , the tolerance conforms to grade N of ISO 11922-1<sup>[3]</sup>.

For  $d_n > 250$ , the tolerance conforms to grade M of ISO 11922-1<sup>[3]</sup>. The requirement for out-of-roundness is only applicable prior to storage.

<sup>d</sup> For a  $d_n$  of 12 to 1 000, the tolerance conforms to 0,5 grade M of ISO 11922-1<sup>[3]</sup>. The requirement for out-of-roundness is only applicable prior to the pipe leaving the manufacturer's premises.

## 6.4 Wall thickness and their tolerances

The nominal wall thickness,  $e_n$ , is classified with the pipe series S. The nominal wall thickness corresponds to the minimum allowable wall thickness.

The nominal wall thickness shall conform to Table 2, as appropriate to the pipe series.

The tolerance for wall thickness,  $e$ , shall conform to Table 3.

**Table 2 — Nominal (minimum) wall thicknesses**

Nominal outside diameter, $d_n$	Pipe series S						
	Nominal (minimum) wall thickness						
	S 20 (SDR 41)	S 16 (SDR 33)	S 12,5 (SDR 26)	S 10 (SDR 21)	S 8 (SDR 17)	S 6,3 (SDR 13,6)	S 5 (SDR 11)
	Nominal pressure PN based on design coefficient $C = 2,5$						
	PN 6	PN 8	PN 10	PN 12,5	PN 16	PN 20	
12	—	—	—	—	—	—	1,5
16	—	—	—	—	—	—	1,5
20	—	—	—	—	—	1,5	1,9
25	—	—	—	—	1,5	1,9	2,3
32	—	1,5	1,6	1,6	1,9	2,4	2,9
40	1,5	1,6	1,9	1,9	2,4	3,0	3,7
50	1,6	2,0	2,4	2,4	3,0	3,7	4,6
63	2,0	2,5	3,0	3,0	3,8	4,7	5,8
75	2,3	2,9	3,6	3,6	4,5	5,6	6,8
90	2,8	3,5	4,3	4,3	5,4	6,7	8,2
	Nominal pressure PN based on design coefficient $C = 2,0^a$						
	PN 6	PN 8	PN 10	PN 12,5	PN 16	PN 20	PN 25
110	2,7	3,4	4,2	5,3	6,6	8,1	10,0
125	3,1	3,9	4,8	6,0	7,4	9,2	11,4
140	3,5	4,3	5,4	6,7	8,3	10,3	12,7
160	4,0	4,9	6,2	7,7	9,5	11,8	14,6
180	4,4	5,5	6,9	8,6	10,7	13,3	16,4
200	4,9	6,2	7,7	9,6	11,9	14,7	18,2
225	5,5	6,9	8,6	10,8	13,4	16,6	—
250	6,2	7,7	9,6	11,9	14,8	18,4	—
280	6,9	8,6	10,7	13,4	16,6	20,6	—
315	7,7	9,7	12,1	15,0	18,7	23,2	—
355	8,7	10,9	13,6	16,9	21,1	26,1	—
400	9,8	12,3	15,3	19,1	23,7	29,4	—
450	11,0	13,8	17,2	21,5	26,7	33,1	—
500	12,3	15,3	19,1	23,9	29,7	36,8	—
560	13,7	17,2	21,4	26,7	—	—	—
630	15,4	19,3	24,1	30,0	—	—	—
710	17,4	21,8	27,2	—	—	—	—
800	19,6	24,5	30,6	—	—	—	—
900	22,0	27,6	—	—	—	—	—
1 000	24,5	30,6	—	—	—	—	—

<sup>a</sup> To apply a design coefficient of 2,5 (instead of 2,0) for pipes with nominal diameters above 90 mm, the next higher pressure rating, PN, shall be chosen.

NOTE 1 The nominal wall thicknesses conform to ISO 4065<sup>[4]</sup>.

NOTE 2 The PN 6 values for S 20 and S 16 are calculated with the preferred number 6,3.

Table 3 — Tolerance on wall thicknesses at any point

Dimensions in millimetres

Nominal (minimum) wall thickness $e_n$		Tolerance for wall thickness $x$	Nominal (minimum) wall thickness $e_n$		Tolerance for wall thickness $x$
>	≤		>	≤	
1,0	2,0	0,4	21,0	22,0	2,4
2,0	3,0	0,5	22,0	23,0	2,5
3,0	4,0	0,6	23,0	24,0	2,6
4,0	5,0	0,7	24,0	25,0	2,7
5,0	6,0	0,8	25,0	26,0	2,8
6,0	7,0	0,9	26,0	27,0	2,9
7,0	8,0	1,0	27,0	28,0	3,0
8,0	9,0	1,1	28,0	29,0	3,1
9,0	10,0	1,2	29,0	30,0	3,2
10,0	11,0	1,3	30,0	31,0	3,3
11,0	12,0	1,4	31,0	32,0	3,4
12,0	13,0	1,5	32,0	33,0	3,5
13,0	14,0	1,6	33,0	34,0	3,6
14,0	15,0	1,7	34,0	35,0	3,7
15,0	16,0	1,8	35,0	36,0	3,8
16,0	17,0	1,9	36,0	37,0	3,9
17,0	18,0	2,0	37,0	38,0	4,0
18,0	19,0	2,1			
19,0	20,0	2,2			
20,0	21,0	2,3			

NOTE 1 The tolerance applies to the nominal (minimum) wall thickness and is expressed in the form  $^{+x}_0$  mm, where  $x$  is the value of tolerance for the mean wall thickness,  $e_m$ .

NOTE 2 The tolerance for wall thickness,  $e$ , at any point, conforms to grade W of ISO 11922-1<sup>[3]</sup>.

6.5 Length of pipe

The nominal pipe length,  $l$ , shall be a minimum length which does not include the depth of the socketed portions, as shown in Figure 1.

NOTE The preferred nominal length of pipe is 6 m. Other lengths are subject to agreement between the manufacturer and the purchaser.

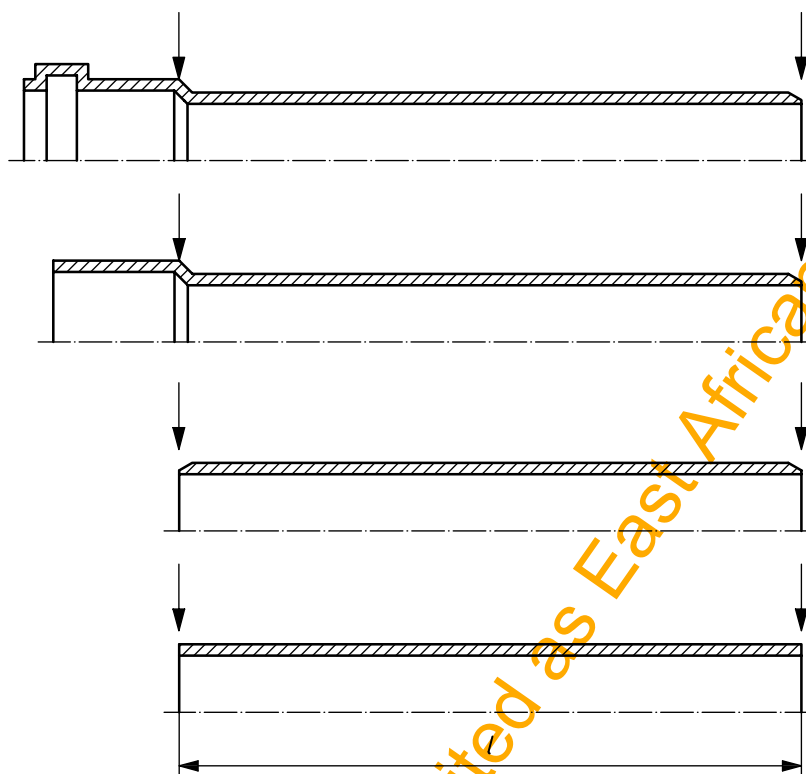

Figure 1 — Points of measurement for nominal pipe lengths

## 6.6 Pipes with sockets

### 6.6.1 Sockets for solvent cementing

The dimensions of sockets for solvent cementing are given in Figure 2. They shall conform to Table 4.

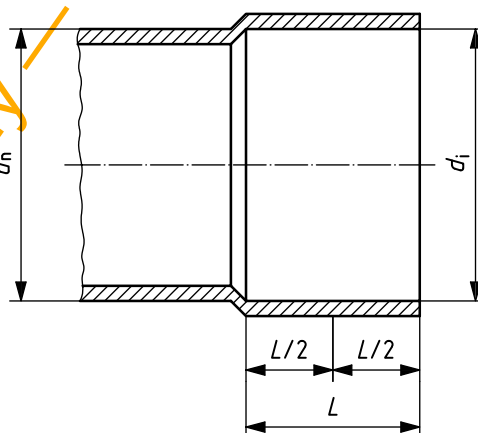

Figure 2 — Socket for solvent cementing

The nominal inside diameter of a socket shall be equal to the nominal outside diameter,  $d_n$ , of the pipe.

The maximum included internal angle of the socketed portion shall not exceed  $0^{\circ}30'$  (30 min).

The requirements for mean inside diameters,  $d_{im}$ , of sockets shall apply at the midpoint of the socket length.

Table 4 — Dimensions of sockets for solvent cementing

Dimensions in millimetres

Nominal inside diameter of socket $d_n$	Mean inside diameter of socket		Maximum out-of-roundness for $d_i$ a	Minimum socket length $L_{min}^b$
	$d_{im, min}$	$d_{im, max}$		
12	12,1	12,3	0,25	12,0
16	16,1	16,3	0,25	14,0
20	20,1	20,3	0,25	16,0
25	25,1	25,3	0,25	18,5
32	32,1	32,3	0,25	22,0
40	40,1	40,3	0,25	26,0
50	50,1	50,3	0,3	31,0
63	63,1	63,3	0,4	37,5
75	75,1	75,3	0,5	43,5
90	90,1	90,3	0,6	51,0
110	110,1	110,4	0,7	61,0
125	125,1	125,4	0,8	68,5
140	140,2	140,5	0,9	76,0
160	160,2	160,5	1,0	86,0
180	180,2	180,6	1,1	96,0
200	200,2	200,6	1,2	106,0
225	225,3	225,7	1,4	118,5
250	250,3	250,8	1,5	131,0
280	280,3	280,9	1,7	146,0
315	315,4	316,0	1,9	163,5
355	355,4	356,1	2,0	183,5
400	400,4	401,2	2,0	206,0

a The out-of-roundness tolerances are rounded values of 0,25 grade M to ISO 11922-1<sup>[3]</sup>.

b The minimum socket lengths are equal to  $(0,5d_n + 6 \text{ mm})$  or 12 mm if  $(0,5d_n + 6 \text{ mm}) \leq 12 \text{ mm}$ .

### 6.6.2 Sockets for elastomeric ring seal type joints

The minimum depth of engagement,  $m_{min}$ , of single sockets with elastomeric ring seal joints (see Figure 3) is based on pipe lengths up to 12 m and shall conform to Table 5.

The wall thickness of the sockets at any point, except the sealing ring groove, shall not be less than the minimum wall thickness of the connecting pipe. The wall thickness of the sealing ring groove shall not be less than 0,8 times the minimum wall thickness of the connecting pipe.

The requirements for mean inside diameters,  $d_{im}$ , of sockets shall apply at the midpoint of the depth of engagement,  $m$ .

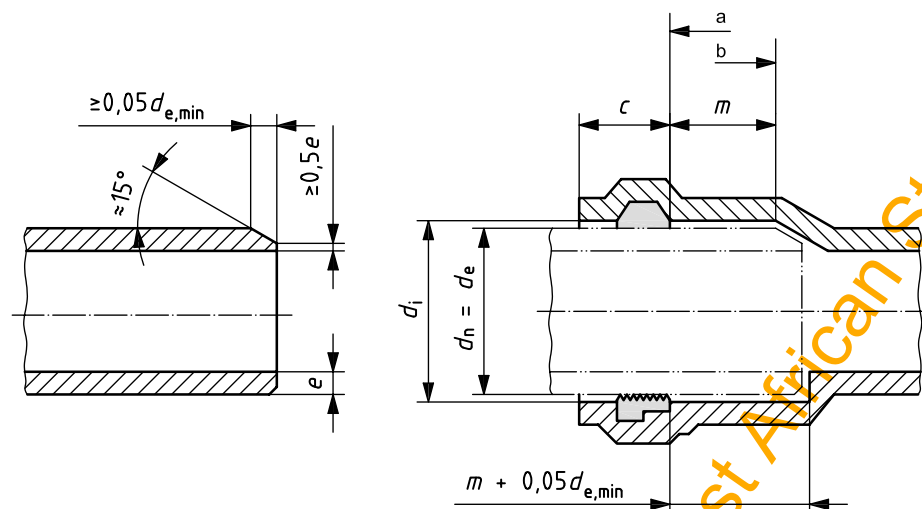
**Key**

- a Start of sealing area.
- b End of cylindrical part of socket and pipe.

**Figure 3 — Socket and spigot end for pipes with elastomeric sealing**

Figure 3 shows the engagement if the spigot end is pushed to the socket bottom.

NOTE For assembly instructions, see ISO/TR 4191 [1].

Table 5 — Dimensions of sockets for elastomeric ring seal joints

Dimensions in millimetres

Nominal inside diameter of socket $d_n$	Minimum mean inside diameter of socket $d_{im, min}^a$	Maximum permissible out-of-roundness for $d_1^b$		Minimum depth of engagement $m_{min}^c$	Length of socket entrance and sealing area $c^d$
		S 20 to S 16	S 12,5 to S 5		
20	20,3	—	0,3	55	27
25	25,3	—	0,3	55	27
32	32,3	0,6	0,3	55	27
40	40,3	0,8	0,4	55	28
50	50,3	0,9	0,5	56	30
63	63,4	1,2	0,6	58	32
75	75,4	1,2	0,7	60	34
90	90,4	1,4	0,9	61	36
110	110,5	1,7	1,1	64	40
125	125,5	1,9	1,2	66	42
140	140,6	2,1	1,3	68	44
160	160,6	2,4	1,5	71	48
180	180,7	2,7	1,7	73	51
200	200,7	3,0	1,8	75	54
225	225,8	3,4	2,1	78	58
250	250,9	3,8	2,3	81	62
280	281,0	5,1	2,6	85	67
315	316,1	5,7	2,9	88	72
355	356,2	6,5	3,3	90	79
400	401,3	7,2	3,6	92	86
450	451,5	8,1	4,1	95	94
500	501,6	9,0	4,5	97	102
560	561,8	10,2	5,1	101	112
630	632,0	11,4	5,7	105	123
710	712,3	12,9	6,5	109	136

<sup>a</sup>  $d_{im, min}$  is measured in the middle of the engagement,  $m$ , and is calculated using the applicable Equation (1), (2) or (3):

$$d_{im, min} = d_n + 0,3 \text{ mm} \tag{1}$$

when  $d_n \leq 50$ ;

$$d_{im, min} = d_n + 0,4 \text{ mm} \tag{2}$$

when  $63 \leq d_n \leq 90$ ;

$$d_{im, min} = 1,003 d_n + 0,1 \text{ mm} \tag{3}$$

when  $d_n \geq 110$ .

The values obtained shall be rounded to the next greater 0,1 mm.

<sup>b</sup> The out-of-roundness tolerances are rounded values of 0,75 grades to ISO 11922-1<sup>[3]</sup> for S 20 to S 16 as follows:

0,75 grade M for  $32 \leq d_n \leq 50$ ;

0,75 grade N for  $63 \leq d_n \leq 250$ ;

0,75 grade M for  $280 \leq d_n \leq 710$ .

For pipe series S 12,5 to S 5: 0,375 grade M, except 0,3 grade M for  $d_n \leq 32$ .

<sup>c</sup> The value of  $m_{min}$  is calculated from the applicable Equation (4) or (5):

$$m_{min} = 50 \text{ mm} + 0,22d_n - 2e \text{ (S 10)}, \tag{4}$$

when  $d_n \leq 280$ ;

$$m_{min} = 70 \text{ mm} + 0,15d_n - 2e \text{ (S 10)}, \tag{5}$$

when  $d_n > 280$ .

The values obtained shall be rounded to the next greater 1,0 mm.

<sup>d</sup> The value of  $c$  is calculated using the following equation:  $c = 22 + 0,16d_n$  and  $c$  is given only for guidance in calculating minimum spigot lengths. The manufacturer shall state the  $c$ -values in his catalogue.

## 6.7 Pipe ends for ring seal or solvent cement joints

Pipes with plain ends intended to be used with elastomeric ring seal sockets shall be chamfered as shown in Figure 3. Pipes with plain ends intended to be used for solvent cement joints shall have all the sharp edges removed.

## 7 Classification and selection of pipes

### 7.1 Classification

Pipes shall be classified according to their nominal pressure, PN, and the pipe series S.

### 7.2 Selection of nominal pressure and pipe series S for water up to and including 25 °C

The nominal pressure, PN, the pipe series S and the design stress,  $\sigma_s$ , are connected by the relationship in Equation (6):

$$PN = \frac{10\sigma_s}{S} \quad (6)$$

The applicable pipe series shall be taken from Table 2.

### 7.3 Determination of the allowable operating pressure for water up to 45 °C

The allowable operating pressure, PFA, for temperatures up to and including 25 °C shall be equal to the nominal pressure, PN.

To determine the allowable operating pressure, PFA, for temperatures between 25 °C and 45 °C, a supplementary derating factor,  $f_T$ , shall be applied to the nominal pressure, PN, as given in Equation (7):

$$PFA = f_T \times PN \quad (7)$$

This factor is given in Figure A.1.

NOTE Another derating factor,  $f_A$ , can be used, taking account of the application. Normally  $f_A$  equals 1. For other values, see related installation documents, e.g. ISO/TR 4191<sup>[1]</sup>.

## 8 Mechanical characteristics

### 8.1 Impact strength

Pipes with a nominal wall thickness of 14,9 mm or less, if tested for resistance to external blows at 0 °C in accordance with EN 744 shall have a true impact rate (TIR) of not more than 10 % when tested at the levels given in Table 6.

Pipes in the series S 5 to S 10 shall be tested at the medium level M and pipes in the series S 12,5 to S 20 shall be tested at the high level H.

The type of the striker shall be as given in EN 744:1995, Table 2, depending on the mass of the falling weight.

The sampling procedure shall conform to EN 744.

NOTE For practical reasons, this test cannot be applied for pipes with  $d_n < 20$  mm.

Table 6 — Requirements for the falling weight impact test

Nominal outside diameter $d_n$ mm	Medium level M			High level H		
	Mass of falling weight kg	Fall height m	Impact energy <sup>ab</sup> Nm	Mass of falling weight kg	Fall height m	Impact energy <sup>ab</sup> Nm
20	0,5	0,4	2	0,5	0,4	2
25	0,5	0,5	2,5	0,5	0,5	2,5
32	0,5	0,6	3	0,5	0,6	3
40	0,5	0,8	4	0,5	0,8	4
50	0,5	1,0	5	0,5	1,0	5
63	0,8	1,0	8	0,8	1,0	8
75	0,8	1,0	8	0,8	1,2	9,5
90	0,8	1,2	9,5	1,0	2,0	20
110	1,0	1,6	16	1,6	2,0	31
125	1,25	2,0	25	2,5	2,0	49
140	1,6	1,8	28	3,2	1,8	57
160	1,6	2,0	31	3,2	2,0	63
180	2,0	1,8	35	4,0	1,8	71
200	2,0	2,0	39	4,0	2,0	78
225	2,5	1,8	44	5,0	1,8	88
250	2,5	2,0	49	5,0	2,0	98
280	3,2	1,8	57	6,3	1,8	111
≥315	3,2	2,0	63	6,3	2,0	124

<sup>a</sup> Based on  $g = 9,81 \text{ m/s}^2$ .

<sup>b</sup> For less than 10, rounded off to 0,5; for greater than 10, rounded off to integers.

8.2 Resistance to internal pressure

Pipes shall withstand, without bursting or leakage, the hydrostatic stress induced by internal hydrostatic pressure when tested in accordance with ISO 1167-1, using the test conditions specified in Table 7.

For this test, end caps type A or B in accordance with ISO 1167-1 may be used. In case of dispute, end caps type A shall be used.

Table 7 — Pressure test requirements for pipes

Characteristic	Requirement	Test parameters					Test method
		Temp. °C	Circumferential stress MPa	Time h	Type of test	Number of test pieces <sup>a</sup>	
Short- and long-term strength	No failure during the test	20	42,0	1	Water in water	3	ISO 1167-1 and ISO 1167-2
		60	12,5 <sup>b</sup>	1 000			

<sup>a</sup> The number of test pieces given indicates the number required to establish a value for the characteristic described in the table. The number of test pieces required for factory production control and process control should be listed in the manufacturer's quality plan.

<sup>b</sup> If tested with the circumferential stress of 12,5 MPa, due to statistical spread of the test results, test times less than 1 000 h can be achieved. In this case, a retest procedure with a circumferential stress of 12,5 MPa or 10,0 MPa shall be performed with pipes of the same production batch and double sampling. If the retest results are positive, the requirement of the minimum reference curve for PVC-U 250, given in ISO 1452-1:2009, 4.4.2, is deemed to be verified.

Integral sockets shall be tested in accordance with ISO 1167-1, using the test parameters given in Table 8. For this test, end caps type B in accordance with ISO 1167-1 may be used and the socket entrance may be externally reinforced to prevent a displacement of the sealing ring.

**Table 8 — Pressure test requirements for all types of integral sockets on pipes**

Characteristic	Requirement	Test parameters						Test method
		Nominal diameter $d_n$	Temp. °C	Pressure bar	Time h	Type of test	Number of test pieces <sup>a</sup>	
Short-term strength	No failure during the test	≤ 90 mm	20	4,2 × PN	1	Water in water	3	ISO 1167-1 and ISO 1167-2
		> 90 mm	20	3,36 × PN	1		3	

<sup>a</sup> The number of test pieces given indicates the number required to establish a value for the characteristic described in the table. The number of test pieces required for factory production control and process control should be listed in the manufacturer's quality plan.

## 9 Physical characteristics

When tested in accordance with the test methods as specified in Table 9 using the indicated parameters, the pipe shall have physical characteristics conforming to the requirements given in Table 9.

**Table 9 — Physical characteristics**

Characteristic	Requirement	Test parameters		Test method
Vicat softening temperature (VST)	≥ 80 °C	Shall conform to ISO 2507-1 Number of test pieces <sup>a</sup> : 3		ISO 2507-1
Longitudinal reversion	Maximum 5 %	Test temperature:	(150 ± 2) °C	ISO 2505, Method: liquid bath <sup>b</sup>
		Number of test pieces <sup>a</sup>	3	
		Test period for:	15 min 30 min	
		$e \leq 8$ mm		
		$e > 8$ mm		
		or		
		Test temperature	(150 ± 2) °C	ISO 2505, Method: hot air oven
		Number of test pieces <sup>a</sup>	3	
		Test period for:	60 min 120 min 240 min	
		$e \leq 8$ mm		
		8 mm < $e \leq 16$ mm		
		$e > 16$ mm		
Resistance to dichloromethane at a specific temperature (Degree of gelation)	No attack at any part of the surface of the test piece	Temperature of bath	(15 ± 1) °C	ISO 9852
		Number of test pieces <sup>a</sup>	1	
		Immersion time	30 min	
		Min. wall thickness	1,5 mm	
Uniaxial tensile test (Alternative test method. In case of dispute resistance to dichloromethane shall be used)	Maximum stress ≥ 45 MPa Strain at break ≥ 80 %	Test speed	5 ± 1 mm/min	ISO 6259-1 and ISO 6259-2
		Test temperature	(23 ± 2) °C	
DSC (Alternative test method to resistance to dichloromethane) <sup>c</sup>	B onset temperature ≥ 185 °C	Shall conform to ISO 18373-1 Number of test pieces: 4		ISO 18373-1

<sup>a</sup> The number of test pieces given indicates the number required to establish a value for the characteristic described in the table. The number of test pieces required for factory production control and process control should be listed in the manufacturer's quality plan.

<sup>b</sup> In case of dispute, the liquid bath method shall be used.

<sup>c</sup> This test is not intended to be used for factory production control. In case of dispute, the resistance to dichloromethane shall be used.

## 10 Sealing rings

The material of the elastomeric sealing ring used in joint assemblies for pipes shall be chosen from EN 681-1 and shall conform to the appropriate class.

The sealing ring shall have no detrimental effect on the properties of the pipe and shall not cause the test assembly to fail the functional requirements of ISO 1452-5.

## 11 Adhesives

The adhesive(s) shall have no detrimental effects on the pipe and shall not cause the test assembly to fail to conform to ISO 1452-5.

The adhesives shall be identified in accordance with ISO 7387-1 and their properties shall conform to ISO 9311-1.

## 12 Performance requirements

When pipes conforming to this part of ISO 1452 are jointed to each other or to components conforming to other parts of ISO 1452, the pipes and the joints shall conform to ISO 1452-5.

## 13 Marking

### 13.1 General

The marking elements shall be printed or formed directly on the pipe with a maximum interval of 1 m in such a way that after storage, weathering, handling and installation, legibility is maintained during the use of the products.

NOTE The manufacturer is not responsible for marking being illegible due to actions caused by installation and use such as painting, scratching, covering of the pipes or by use of detergents on the pipe.

Marking shall not initiate cracks or other types of defects which would impair conformity to the requirements of this part of ISO 1452.

If printing is used, the colouring of the printed information shall differ from the basic colouring of the pipe.

The size of the marking shall be such that the marking is legible without magnification.

### 13.2 Minimum required marking

The minimum required marking on pipes shall conform to Table 10.

Table 10 — Minimum required marking on pipes

Aspects	Mark or symbol
<ul style="list-style-type: none"> <li>– Number of this International Standard</li> <li>– Manufacturer's name and/or trademark</li> <li>– Material</li> <li>– Nominal outside diameter <math>d_n</math> × wall thickness <math>e_n</math></li> <li>– Nominal pressure PN<sup>a</sup></li> <li>– Manufacturer's information<sup>b</sup></li> <li>– Intended use<sup>c</sup></li> </ul>	ISO 1452 xyz PVC-U e.g. 110 × 6,6 e.g. PN 16 e.g. 90.06.14 e.g. W/P
<p><sup>a</sup> The marking of the pipe series S may be included, e.g. PN 16/S 8.</p> <p><sup>b</sup> To provide traceability, the following details shall be given:</p> <ul style="list-style-type: none"> <li>— the production period, the year, in figures or in code;</li> <li>— a name or code for the production site, if the manufacturer is producing in different sites, nationally and/or internationally;</li> <li>— identification of the extrusion line, if relevant.</li> </ul> <p><sup>c</sup> For information on abbreviations, see CEN/TR 15438<sup>[5]</sup> and/or national rules.</p>	

### 13.3 Additional marking

Pipes conforming to this part of ISO 1452 and also conforming to other standard(s) may be marked additionally with the number(s) of the other standard(s), together with the minimum required marking in accordance with the other standard(s).

Pipes conforming to this part of ISO 1452, which are third party certified, may be marked accordingly.

## Annex A (normative)

### Allowable operating pressures

#### A.1 Nominal pressures of pipes

The nominal pressure, PN, of a pipe shall be designated in accordance with Table A.1, depending on the diameter of the pipe and the pipe series S.

Table A.1 — Nominal pressures of pipes

Nominal diameter $d_n$	Nominal pressures						
	Pipe series						
	S 20 (SDR 41)	S 16 (SDR 33)	S 12,5 (SDR 26)	S 10 (SDR 21)	S 8 (SDR 17)	S 6,3 (SDR 13,6)	S 5 (SDR 11)
$\leq 90$	—	PN 6	PN 8	PN 10	PN 12,5	PN 16	PN 20
$> 90$	PN 6	PN 8	PN 10	PN 12,5	PN 16	PN 20	PN 25

#### A.2 Nominal pressures of the system

All system components conforming to this part of ISO 1452 shall be classified and marked with PN and optionally with the pipe series S. Every component can be used at a temperature up to and including 25 °C for an operating pressure in bar equal to or less than the indicated PN.

This means that fittings and valves may be used in combination with pipes marked with the same or lower PN.

The whole system allows the operating pressure to be equal to or less than that of the component having the lowest pressure rating.

#### A.3 Derating factor for service temperatures between 25 °C and 45 °C

The derating factor,  $f_T$ , for service temperatures between 25 °C up to 45 °C shall be taken from Figure A.1. The derating factor is based on long-term experience and test results.

**EXAMPLE** Consider a pipe with PN 12,5 to be applied for water at 40 °C. From Figure A.1 the derating factor at 40 °C is 0,71. Therefore the maximum allowable operating pressure at 40 °C in continuous use is:  $0,71 \times 12,5 \text{ bar} = 8,88 \text{ bar}$ .

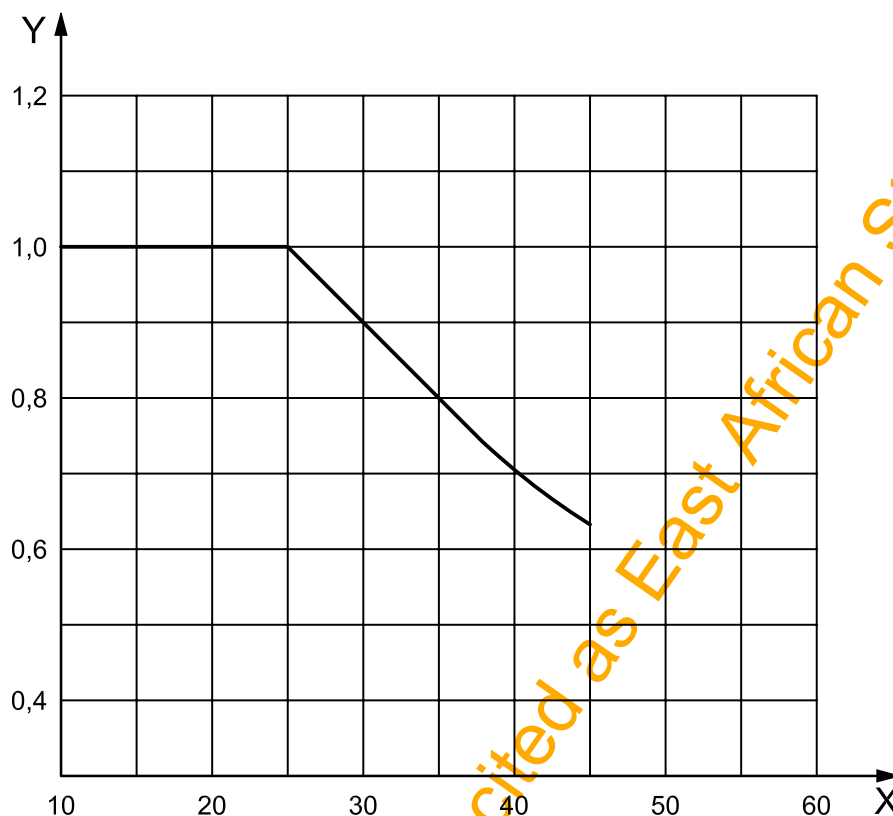
**Key**

- X service temperature, in degrees Celsius  
 Y derating factor,  $f_T$

**Figure A.1 — Derating factor,  $f_T$ , for service temperatures up to 45 °C**

#### A.4 Derating factor related to application of the system

For applications which need additional derating factors, e.g. more safety than included in the overall service (design) coefficient of 2,0 or 2,5, an additional factor,  $f_A$ , shall be chosen at the design stage.

The allowable operating pressure, PFA, in continuous use shall be calculated using Equation (A.1):

$$PFA = f_T \times f_A \times PN \quad (A.1)$$

where:

PFA is the allowable operating pressure;

$f_T$  is the derating factor for service temperatures between 25 °C and 45 °C;

$f_A$  is the derating factor related to the application;

PN is the nominal pressure.

NOTE 1 PFA and PN are expressed in the same unit of pressure, preferably in bars.

NOTE 2 Where there is no specific requirement,  $f_A = 1$ .

## Annex B (normative)

### Imperial (inch)-sized pipes

#### B.1 General

All clauses of this part of ISO 1452 shall apply, together with the following clauses. The specifications given in this annex are for the requirements which differ from those given in Clauses 1 to 13.

#### B.2 Geometrical characteristics

##### B.2.1 Mean outside diameters and their tolerances

For the purposes of 6.3, Table B.1 shall apply in place of Table 1.

**Table B.1 — Mean outside diameters and tolerances**

Dimensions in millimetres

Nominal size in	Mean outside diameter		Tolerance for out-of-roundness
	$d_{em, min}$	$d_{em, max}$	
3/8	17,0	17,3	0,3
1/2	21,2	21,5	0,3
3/4	26,6	26,9	0,3
1	33,4	33,7	0,5
1 1/4	42,1	42,4	0,5
1 1/2	48,1	48,4	0,5
2	60,2	60,5	0,7
3	88,7	89,1	1,0
4	114,1	114,5	1,2
6	168,0	168,5	1,7
8	218,8	219,4	2,2
10	272,6	273,4	2,8
12	323,4	324,3	3,3
16	405,9	406,9	4,2
18	456,7	457,7	4,6
20	507,5	508,5	5,2
24	609,1	610,1	6,2

##### B.2.2 Wall thicknesses and their tolerances

For the purposes of 6.4, the following shall apply.

The nominal wall thicknesses,  $e_n$ , shall be classified according to the PN rating of the pipe, as given in Table B.2.

The tolerances on the wall thickness at any point shall conform to Table B.3.

Table B.2 — Nominal wall thicknesses

Dimensions in millimetres

Nominal size	Nominal wall thickness <i>e</i>		
	in	PN 9	PN 12
3/8	—	—	1,5
1/2	—	—	1,7
3/4	—	—	1,9
1	—	—	2,2
1 1/4	—	2,2	2,7
1 1/2	—	2,5	3,1
2	2,5	3,1	3,9
3	3,5	4,6	5,7
4	4,5	6,0	7,3
6	6,6	8,8	10,8
8	7,8	10,3	12,6
10	9,7	12,8	15,7
12	11,5	15,2	18,7
16	14,5	19,0	23,4
18	16,3	21,4	—
20	18,1	—	—
24	21,7	—	—

Table B.3 — Tolerance on wall thickness at any point

Dimensions in millimetres

Nominal size	Tolerance <i>x</i> on wall thickness <sup>a</sup>		
	in	PN 9	PN 12
3/8	—	—	0,4
1/2	—	—	0,4
3/4	—	—	0,6
1	—	—	0,6
1 1/4	—	0,5	0,6
1 1/2	—	0,5	0,6
2	0,5	0,6	0,6
3	0,6	0,7	0,9
4	0,7	0,9	1,1
6	1,0	1,4	1,7
8	1,2	1,6	1,9
10	1,5	2,0	2,4
12	1,8	2,3	2,9
16	2,2	2,9	3,6
18	2,5	3,3	—
20	2,8	—	—
24	3,3	—	—

<sup>a</sup> The tolerance is expressed in the form of  ${}^{+x}_0$  mm, where *x* is the value of the tolerance on the minimum wall thickness.

**B.2.3 Pipes with sockets**

**B.2.3.1 Sockets for solvent cementing**

For the purposes of 6.6.1, the following shall apply.

The dimensions of sockets for solvent cementing are shown in Figure B.1. They shall conform to the values given in Table B.4.

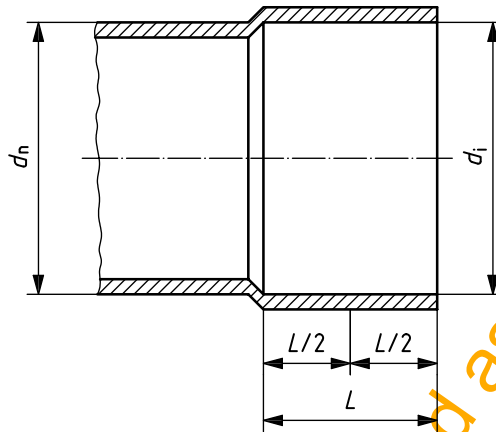

**Figure B.1 — Socket on pipe end for solvent cementing**

At no point shall the inside diameter of the socket be greater than the mouth inside diameter of the associated socket. The mean inside diameter of the socket may decrease from mouth to root by the following maximum total included angle of taper:

3/8" to 2" nominal size: 0°40';

3" nominal size and greater: 0°30'.

An out-of-roundness tolerance of  $\pm 0,2\%$  is allowed on the mean inside diameter of the socket at the midpoint of the socket length.

**Table B.4 — Dimensions of sockets for solvent cementing**

Dimensions in millimetres

Nominal size in	Socket length $L_{min}$	Mean inside diameter of socket at midpoint of socket length	
		$d_{im, min}$	$d_{im, max}$
3/8	14,5	17,1	17,3
1/2	16,5	21,3	21,5
3/4	19,5	26,7	26,9
1	22,5	33,5	33,7
1 1/4	27,0	42,2	42,4
1 1/2	30,0	48,2	48,4
2	36,0	60,3	60,5
3	50,5	88,8	89,1
4	63,0	114,2	114,5
6	90,0	168,2	168,5
8	115,5	219,0	219,4
10	142,5	272,8	273,4
12	168,0	323,7	324,3

NOTE The minimum socket lengths,  $L_{min}$ , are calculated using Equation (B.1):  

$$L_{min} = 0,5 d_{em, min} + 6 \text{ mm} \quad (B.1)$$
 where  $d_{em, min}$  is the minimum mean outside diameter of the corresponding pipe (see ISO 1452-1).

### B.2.3.2 Sockets for elastomeric ring seal joints

For the purposes of 6.6.2, the following shall apply.

The depth of engagement,  $m$ , of single sockets with elastomeric sealing ring type joints are shown in Figure B.2. The minimum value for  $m$  shall conform to the applicable value given in Table B.5.

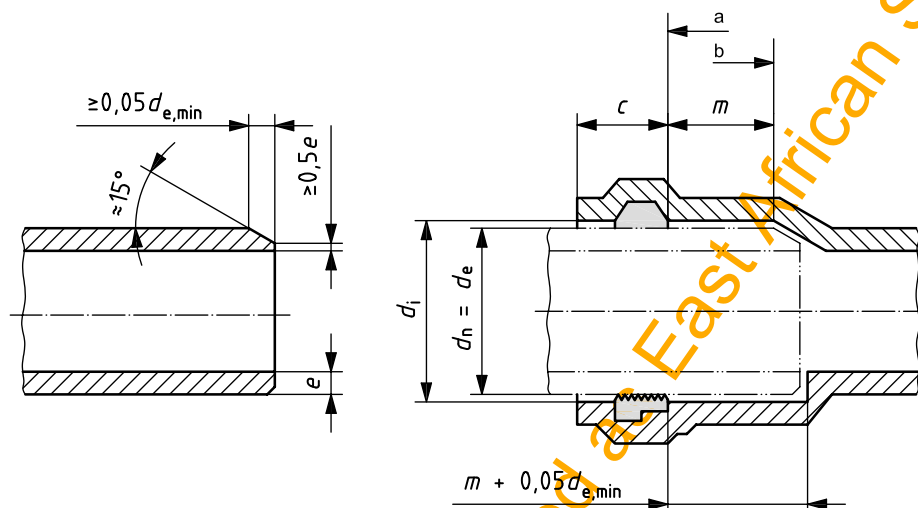

#### Key

- a Start of sealing area.
- b End of cylindrical part of socket and pipe.

**Figure B.2 — Socket and spigot end for pipes with elastomeric sealing ring**

NOTE 1 Figure B.2 shows the engagement if the spigot end is pushed to the socket bottom.

NOTE 2 For assembly instructions, see ISO/TR 4191<sup>[1]</sup>.

**Table B.5 — Dimensions of sockets for elastomeric ring seal joints**

Dimensions in millimetres

Nominal size in	Minimum depth of engagement $m_{\min}$	
	Single socket	Double socket
2	67	39
3	70	43
4	75	47
6	87	55
8	98	63
10	110	71
12	121	78
16	139	91
18	150	98
20	171	106
24	183	121

### **B.3 Classification and choice of pipes**

For classification and selection, 7.1 and 7.2 shall not apply to imperial (inch)-sized pipes.

### **B.4 Physical characteristics**

The characteristics given in Table 9 shall be applied to imperial-sized pipes.

*Draft for comments only — Not to be cited as East African Standard*

## Bibliography

- [1] ISO/TR 4191, *Unplasticized polyvinyl chloride (PVC-U) pipes for water supply — Recommended practices for laying*
- [2] ENV 1452-7, *Plastics piping systems for water supply — Unplasticized poly(vinyl chloride) (PVC-U) — Part 7: Guidance for the assessment of conformity*
- [3] ISO 11922-1, *Thermoplastics pipes for the conveyance of fluids — Dimensions and tolerances — Part 1: Metric series*
- [4] ISO 4065, *Thermoplastics pipes — Universal wall thickness table*
- [5] CEN/TR 15438, *Plastics piping systems — Guidance for coding of products and their intended uses*

Draft for comments only — Not to be cited as East African Standard

---

---

**ICS 23.040.20; 23.040.45; 91.140.60; 93.025**

Price based on 23 pages

*Draft for comments only — Not to be cited as East African Standard*