



CD/K/017:2008
ICS 43.040.60

EAST AFRICAN STANDARD

Uniform provisions concerning the approval of vehicles with regard to the seats, their anchorages and any head restraints

EAST AFRICAN COMMUNITY

Foreword

Development of the East African Standards has been necessitated by the need for harmonizing requirements governing quality of products and services in East Africa. It is envisaged that through harmonized standardization, trade barriers which are encountered when goods and services are exchanged within the Community will be removed.

In order to meet the above objectives, the EAC Partner States have enacted an East African Standardization, Quality Assurance, Metrology and Test Act, 2006 (EAC SQMT Act, 2006) to make provisions for ensuring standardization, quality assurance, metrology and testing of products produced or originating in a third country and traded in the Community in order to facilitate industrial development and trade as well as helping to protect the health and safety of society and the environment in the Community.

East African Standards are formulated in accordance with the procedures established by the East African Standards Committee. The East African Standards Committee is established under the provisions of Article 4 of the EAC SQMT Act, 2006. The Committee is composed of representatives of the National Standards Bodies in Partner States, together with the representatives from the private sectors and consumer organizations. Draft East African Standards are circulated to stakeholders through the National Standards Bodies in the Partner States. The comments received are discussed and incorporated before finalization of standards, in accordance with the procedures of the Community.

Article 15(1) of the EAC SQMT Act, 2006 provides that "Within six months of the declaration of an East African Standard, the Partner States shall adopt, without deviation from the approved text of the standard, the East African Standard as a national standard and withdraw any existing national standard with similar scope and purpose".

East African Standards are subject to review, to keep pace with technological advances. Users of the East African Standards are therefore expected to ensure that they always have the latest versions of the standards they are implementing.

© East African Community 2010 — All rights reserved*

East African Community

P O Box 1096

Arusha

Tanzania

Tel: 255 27 2504253/8

Fax: 255-27-2504481/2504255

E-Mail: eac@eachq.org

Web: www.each.int

* © 2010 EAC — All rights of exploitation in any form and by any means reserved worldwide for EAC Partner States' NSBs.

Contents

1	Scope	1
2	Definitions	1
3	Application for approval	3
4	Approval	4
5	Requirements	5
6	Tests	10
7	Conformity of production	13
8	Penalties for non-conformity of production	13
9	Modifications of the vehicle type and extension of approval with respect to the seats, their anchorages and/or their head restraints	14
10	Production definitely discontinued	14
11	Instructions for use	14
12	Names and addresses of technical services responsible for conducting approval tests and of administrative departments	14
13	Transitional provisions	14
	Annex 1 Communication	16
	Annex 2 Arrangements of approval marks	18
	Annex 3 Procedure for determining the “H” point and the actual torso angle for seating positions in motor vehicles	22
	Annex 4 Determination of the height and width of head restraints	32
	Annex 5 Details of lines and measurements taken during tests	34
	Annex 6 Test procedure for checking energy dissipation	35
	Annex 7 Method for testing the strength of seat anchorages and their adjustments, locking and displacement systems	37
	Annex 8 Determination of dimension “a” of head restraint gaps	38
	Annex 9 Test procedure for devices intended to protect the occupants against displacement of luggage	40

Uniform provisions concerning the approval of vehicles with regard to the seats, their anchorages and any head restraints

1 Scope

This Regulation applies to the strength of seats, to their anchorages and to their head restraints, of vehicles of categories M1 and N, and to the strength of seats, to their anchorages and to their head restraints, of vehicles of categories M2 and M3, not covered by CD/K/31:2007, *Road vehicles — Strength of seats and their anchorages of large passenger buses*.^{1/ 2/}

It also applies to the design of the rear parts of seat-backs^{2/} and to devices intended to protect the occupants from the danger resulting from the displacement of luggage in a frontal impact, of vehicles of category M1.

It does not apply to folding, side-facing or rearward-facing seats, or to any head restraint fitted to these seats.

2 Definitions

For the purposes of this Regulation

2.1

"Approval of a vehicle"

means the approval of a vehicle type with regard to the strength of the seats and their anchorages, the design of the rear parts of the seat-backs and the characteristics of their head restraints;

2.2

"Vehicle type"

means a category of motor vehicles which do not differ in such essential respects as:

2.2.1

the structure, shape, dimensions, materials and the mass of the seats, although the seats may differ in covering and colour; differences not exceeding 5 per cent in the mass of the approved seat type shall not be considered significant;

2.2.2

the type and dimensions of the adjustment, displacement and locking systems of the seat-back and seats and their parts;

2.2.3

the type and dimensions of the seat anchorages;

2.2.4

the dimensions, frame, materials and padding of head restraints, although they may differ in colour and covering;

2.2.5

the type and dimensions of the attachments of the head restraint and the characteristics of the part of the vehicle to which the head restraint is attached, in the case of a separate head restraint;

^{1/} As defined in the Consolidated Resolution on the Construction of Vehicles (R.E.3.), annex 7 (document TRANS/WP.29/78/Rev.1/Amend.2).

^{2/} The rear parts of seat-backs of vehicles of category M1 are considered to comply with the provisions of paragraphs 5.1.3. and 5.1.4. of this Regulation provided they comply with the provisions of Regulation No. 21 "Uniform Provisions concerning the Approval of Vehicles with regard to their Interior Fittings" (E/ECE/324-E/ECE/TRANS/505/Rev.1/Add.20/Rev.2).

CD/K/017:2008

2.3

"Seat"

means a structure which may or may not be integral with the vehicle structure complete with trim, intended to seat one adult person. The term covers both an individual seat or part of a bench seat intended to seat one person;

2.4

"Bench seat"

means a structure complete with trim, intended to seat more than one adult person;

2.5

"Anchorage"

means the system by which the seat assembly is secured to the vehicle structure, including the affected parts of the vehicle structure;

2.6

"Adjustment system"

means the device by which the seat or its parts can be adjusted to a position suited to the morphology of the seated occupant. This device may, in particular, permit:

2.6.1

longitudinal displacement;

2.6.2

vertical displacement;

2.6.3

angular displacement;

2.7

"Displacement system"

means a device by which the seat or one of its parts can be displaced and/or rotated, without a fixed intermediate position, to permit easy access of occupants to the space behind the seat concerned;

2.8

"Locking system"

means a device ensuring that the seat and its parts are maintained in the position of use;

2.9

"Folding seat"

means an auxiliary seat intended for occasional use and normally folded;

2.10

"Transverse plane"

means a vertical plane perpendicular to the median longitudinal plane of the vehicle;

2.11

"Longitudinal plane"

means a plane parallel to the median longitudinal plane of the vehicle;

2.12

"Head restraint"

means a device whose purpose is to limit the rearward displacement of an adult occupant's head in relation to his torso in order to reduce the danger of injury to the cervical vertebrae in the event of an accident;

2.12.1

"Integrated head restraint"

means a head restraint formed by the upper part of the seat-back. Head restraints meeting the definitions of paragraphs 2.12.2 or 2.12.3 below but which can only be detached from the seat or the

vehicle structure by the use of tools or by partial or complete removal of the seat covering, meet the present definition;

2.12.2

"Detachable head restraint"

means a head restraint consisting of a component separable from the seat designed for insertion and positive retention in the seat-back structure;

2.12.3

"Separate head restraint"

means a head restraint consisting of a component separate from the seat, designed for insertion and/or positive retention in the structure of the vehicle;

2.13

"R point"

means the seating reference point as defined in annex 3 to this Regulation;

2.14

"Reference line"

means the line on the manikin reproduced in annex 3, appendix 1, figure 1, to this Regulation.

2.15

"Partitioning system"

means parts or devices which, in addition to the seat-backs, are intended to protect the occupants from displaced luggage; in particular, a partitioning system may be constituted by netting or wire mesh located above the level of the seat-backs in their upright or folded down position. Head restraints fitted as standard equipment for vehicles equipped with such parts or devices shall be considered as part of the partitioning system. However, a seat equipped with a head restraint shall not be considered as being on its own a partitioning system.

3 Application for approval

3.1 The application for approval of a vehicle type shall be submitted by the vehicle manufacturer or by his duly accredited representative.

3.2 It shall be accompanied by the following documents in triplicate and the following particulars:

3.2.1 A detailed description of the vehicle type with regard to the design of the seats, their anchorages, and their adjustment, displacement and locking systems;

3.2.1.1 A detailed description and/or drawings of the partitioning system, if applicable.

3.2.2 Drawings, on an appropriate scale and in sufficient detail, of the seats, their anchorages on the vehicle, and their adjustment, displacement and locking systems.

3.2.3 In the case of a seat with a detachable head restraint:

3.2.3.1 A detailed description of the head restraint, specifying in particular the nature of the padding material or materials;

3.2.3.2 A detailed description of the location, the type of support and the attachments for mounting the head restraint on the seat.

3.2.4 In the case of a separate head restraint:

3.2.4.1 A detailed description of the head restraint, specifying in particular the nature of the padding material or materials;

3.2.4.2 A detailed description of the location, and the attachments for fitting the head restraint to the structure of the vehicle.

3.3 The following shall be submitted to the technical service responsible for the approval tests:

3.3.1 A vehicle representative of the vehicle type to be approved or the parts of the vehicle which the technical service deems necessary for approval tests;

3.3.2 An additional set of the seats with which the vehicle is equipped, with their anchorages.

3.3.3 For vehicles with seats fitted or capable of being fitted with head restraints, in addition to the requirements set out in 3.3.1 and 3.3.2:

3.3.3.1 in the case of detachable head restraints: an additional set of seats, fitted with head restraints, with which the vehicle is equipped, together with their anchorages.

3.3.3.2 In the case of separate head restraints: an additional set of the seats with which the vehicle is equipped, with their anchorages, an additional set of the corresponding head restraints and the part of the vehicle structure to which the head restraint is fitted, or a complete structure.

4 Approval

4.1 If the vehicle submitted for approval pursuant to this Regulation meets the relevant requirements (seats fitted with head restraints or capable of being fitted with head restraints), approval of the vehicle type shall be granted.

4.2 An approval number shall be assigned to each type approved. Its first two digits (at present 07, corresponding to the 07 series of amendments) shall indicate the series of amendments incorporating the most recent major technical amendments made to the Regulation at the time of issue of the approval. The same Contracting Party may not assign the same number either to the same vehicle type equipped with other types of seats or head restraints or with seats anchored differently on the vehicle (this applies both to seats with and to those without head restraints) or to another vehicle type.

4.3 Notice of approval or extension or refusal of approval of a vehicle type pursuant to this Regulation shall be communicated to the Parties to the Agreement applying this Regulation by means of a form conforming to the model in annex 1 to this Regulation.

4.4 There shall be affixed, conspicuously and in a readily accessible place specified on the approval form, to every vehicle conforming to a vehicle type approved under this Regulation, an international approval mark consisting of:

4.4.1 A circle surrounding the letter "E" followed by the distinguishing number of the country which has granted approval;^{3/}

4.4.2 The number of this Regulation, followed by the letter "R", a dash and the approval number, to the right of the circle prescribed in 4.4.1.

^{3/} 1 for Germany, 2 for France, 3 for Italy, 4 for the Netherlands, 5 for Sweden, 6 for Belgium, 7 for Hungary, 8 for the Czech Republic, 9 for Spain, 10 for Yugoslavia, 11 for the United Kingdom, 12 for Austria, 13 for Luxembourg, 14 for Switzerland, 15 (vacant), 16 for Norway, 17 for Finland, 18 for Denmark, 19 for Romania, 20 for Poland, 21 for Portugal, 22 for the Russian Federation, 23 for Greece, 24 for Ireland, 25 for Croatia, 26 for Slovenia, 27 for Slovakia, 28 for Belarus, 29 for Estonia, 30 (vacant), 31 for Bosnia and Herzegovina, 32 for Latvia, 33 (vacant), 34 for Bulgaria, 35 (vacant), 36 for Lithuania, 37 for Turkey, 38 (vacant), 39 for Azerbaijan, 40 for The former Yugoslav Republic of Macedonia, 41 (vacant), 42 for the European Community (Approvals are granted by its Member States using their respective ECE symbol), 43 for Japan, 44 (vacant), 45 for Australia, 46 for Ukraine, 47 for South Africa and 48 for New Zealand. Subsequent numbers shall be assigned to other countries in the chronological order in which they ratify or accede to the Agreement Concerning the Adoption of Uniform Technical Prescriptions for Wheeled Vehicles, Equipment and Parts which can be Fitted and/or be Used on Wheeled Vehicles and the Conditions for Reciprocal Recognition of Approvals Granted on the Basis of these Prescriptions, and the numbers thus assigned shall be communicated by the Secretary-General of the United Nations to the Contracting Parties to the Agreement.

4.4.3 However, if the vehicle is equipped with one or more seats fitted or capable of being fitted with head restraints, approved as meeting the requirements under paragraphs 5.1 and 5.2 below, the number of this Regulation shall be followed by the letters "RA". The form conforming to the model in annex 1 to this Regulation shall indicate which seat(s) of the vehicle is (are) fitted or capable of being fitted with head restraints. The marking shall also indicate that any remaining seats in the vehicle, not fitted or capable of being fitted with head restraints, are approved and meet the requirements of paragraph 5.1 below of this Regulation.

4.5 If the vehicle conforms to a vehicle type approved under one or more other Regulations annexed to the Agreement in the country which has granted approval under this Regulation, the symbol prescribed in paragraph 4.4.1 need not be repeated; in such a case the Regulation and approval numbers and the additional symbols of all the Regulations under which approval has been granted in the country which has granted approval under this Regulation shall be placed in vertical columns to the right of the symbol prescribed in 4.4.1.

4.6 The approval mark shall be clearly legible and be indelible.

4.7 The approval mark shall be placed close to or on the vehicle data plate affixed by the manufacturer.

4.8 Examples of arrangements of approval marks are given in annex 2 to this Regulation.

5 Requirements

5.1 General requirements applicable to all seats of vehicles of category M1^{4/}

5.1.1 Every adjustment and displacement system provided shall incorporate a locking system, which shall operate automatically. Locking systems for armrests or other comfort devices are not necessary unless the presence of such devices will cause additional risk of injury to the occupants of a vehicle in the event of a collision.

5.1.2 The unlocking control for a device as referred to in paragraph 2.7 shall be placed on the outside of the seat close to the door. It shall be easily accessible, even to the occupant of the seat immediately behind the seat concerned.

5.1.3 The rear parts of seats situated in area 1, defined in paragraph 6.8.1.1 shall pass the energy dissipation test in accordance with the requirements of annex 6 to this Regulation.

5.1.3.1 This requirement is deemed to be met if in the tests carried out by the procedure specified in annex 6 the deceleration of the headform does not exceed 80 g continuously for more than 3 ms. Moreover, no dangerous edge shall occur during or remain after the test.

5.1.3.2 The requirements of paragraph 5.1.3 shall not apply to rearmost seats or to back-to-back seats.

5.1.4 The surface of the rear parts of seats shall exhibit no dangerous roughness or sharp edges likely to increase the risk of severity of injury to the occupants. This requirement is considered as satisfied if the surface of the rear parts of seats tested in the conditions specified in paragraph 6.1 exhibit radii of curvature not less than:

- 2.5 mm in area 1,
- 5.0 mm in area 2,
- 3.2 mm in area 3.

These areas are defined in paragraph 6.8.1.

5.1.4.1 This requirement does not apply to:

^{4/} Vehicles of category M2, which are approved to this Regulation as an alternative to Regulation No. 80 (in line with paragraph 1.2. to that Regulation) shall also meet the requirements of this paragraph.

5.1.4.1.1 The parts of the different areas exhibiting a projection of less than 3.2 mm from the surrounding surface, which shall exhibit blunted edges, provided that the height of the projection is not more than half its width;

5.1.4.1.2 Rearmost seats and back-to-back seats;

5.1.4.1.3 Rear parts of seats situated below a horizontal plane passing through the lowest R point in each row of seats. (Where rows of seats have different heights, starting from the rear, the plane shall be turned up or down forming a vertical step passing through the R point of the row of seats immediately in front);

5.1.4.1.4 Parts such as "flexible wire mesh".

5.1.4.2 In area 2, defined in paragraph 6.8.1.2, surfaces may exhibit radii less than 5 mm, but not less than 2.5 mm provided that they pass the energy-dissipation test prescribed in annex 6 to this Regulation. Moreover, these surfaces must be padded to avoid direct contact of the head with the seat frame structure.

5.1.4.3 If the areas defined above contain parts covered with material softer than 50 Shore A hardness, the above requirements, with the exception of those relating to the energy-dissipation test in accordance with the requirements of annex 6, shall apply only to the rigid parts.

5.1.5 No failure shall be shown in the seat frame or in the seat anchorage, the adjustment and displacement systems or their locking devices during or after the tests prescribed in paragraphs 6.2 and 6.3. Permanent deformations, including ruptures, may be accepted, provided that these do not increase the risk of injury in the event of a collision and the prescribed loads were sustained.

5.1.6 No release of the locking systems shall occur during the tests described in paragraph 6.3 and in annex 9, paragraph 2.1.

5.1.7. After the tests, the displacement systems intended for permitting or facilitating the access of occupants must be in working order; they must be capable, at least once, of being unlocked and must permit the displacement of the seat or the part of the seat for which they are intended.

Any other displacement systems, as well as adjustment systems and their locking systems are not required to be in working order.

In the case of seats provided with head restraints, the strength of the seat-back and of its locking devices is deemed to meet the requirements set out in paragraph 6.2 when, after testing in accordance with paragraph 6.4.3.6, no breakage of the seat or seat-back has occurred: otherwise, it must be shown that the seat is capable of meeting the test requirements set out in paragraph 6.2.

In the case of seats (benches) with more places to sit than head restraints, the test described in paragraph 6.2 shall be carried out.

5.2 General specifications applicable to seats of vehicles of categories N1, N2 and N3 and to seats of vehicles of categories M2 and M3 not covered by Regulation No. 80

5.2.1 Seats and bench seats must be firmly attached to the vehicle.

5.2.2 Sliding seats and bench seats must be automatically lockable in all the positions provided.

5.2.3 Adjustable seat-backs must be lockable in all the positions provided.

5.2.4 All seats which can be tipped forward or have fold-on backs must lock automatically in the normal position.

5.3 Mounting of head restraints

5.3.1 A head restraint shall be mounted on every outboard front seat in every vehicle of category M1. Seats fitted with head restraints, intended for fitment in other seating positions and in other categories of vehicles may also be approved to this Regulation.

5.3.2 A head restraint shall be mounted on every outboard front seat in every vehicle of category M2 with a maximum mass not exceeding 3500 kg and of category N1; head restraints mounted in such vehicles shall comply with the requirements of Regulation No. 25, as amended by the 03 series of amendments.

5.4 Special requirements for seats fitted or capable of being fitted with head restraints

5.4.1 The presence of the head restraint must not be an additional cause of danger to occupants of the vehicle. In particular, it shall not in any position of use exhibit any dangerous roughness or sharp edge liable to increase the risk or seriousness of injury to the occupants.

5.4.2 Parts of the front and rear faces of the head restraints situated in area 1, as defined in paragraph 6.8.1.1.3 below shall pass the energy absorption test.

5.4.2.1 This requirement is deemed to be met if in the tests carried out by the procedure specified in annex 6 the deceleration of the headform does not exceed 80 g continuously for more than 3 ms. Moreover, no dangerous edge shall occur during or remain after the test.

5.4.3 Parts of the front and rear faces of head restraints situated in area 2, as defined in paragraph 6.8.1.2.2 below, shall be so padded as to prevent any direct contact of the head with the components of the structure and shall meet the requirements of paragraph 5.1.4 above applicable to the rear parts of seats situated in area 2.

5.4.4 The requirements of paragraphs 5.4.2 and 5.4.3 above, shall not apply to parts of rear faces of head restraints designed to be fitted to seats behind which no seat is provided.

5.4.5 The head restraint shall be secured to the seat or to the vehicle structure in such a way that no rigid and dangerous parts project from the padding of the head restraint or from its attachment to the seat-back as a result of the pressure exerted by the headform during the test.

5.4.6 In the case of a seat fitted with a head restraint, the provisions of paragraph 5.1.3 may, after agreement of the technical service, be considered to be met if the seat fitted with its head restraint complies with the provisions of paragraph 5.4.2 above.

5.5 Height of head restraints

5.5.1 The height of head restraints shall be measured as described in paragraph 6.5 below.

5.5.2 For head restraints not adjustable for height, the height shall be not less than 800 mm in the case of front seats and 750 mm in the case of other seats.

5.5.3 For head restraints adjustable for height:

5.5.3.1 The height shall be not less than 800 mm in the case of front seats and 750 mm in the case of other seats; this value shall be obtained in a position between the highest and lowest positions to which adjustment is possible;

5.5.3.2 There shall be no "use position" resulting in a height of less than 750 mm;

5.5.3.3 In the case of seats other than the front seats the head restraints may be such that they can be displaced to a position resulting in a height of less than 750 mm, provided that such position is clearly recognizable to the occupant as not being included for the use of the head restraint;

5.5.3.4 In the case of front seats head restraints may be such that they can be automatically displaced when the seat is not occupied, to a position resulting in a height of less than 750 mm, provided that they automatically return to the position of use when the seat is occupied.

5.5.4 The dimensions mentioned in paragraphs 5.5.2 and 5.5.3.1 above may be less than 800 mm in the case of front seats and 750 mm in the case of other seats to leave adequate clearance between the head restraint and the interior surface of the roof, the windows or any part of the vehicle structure; however, the clearance shall not exceed 25 mm. In the case of seats fitted with displacement and/or adjustment systems, this shall apply to all seat positions. Furthermore, by derogation to paragraph 5.5.3.2 above, there shall not be any "use position" resulting in a height lower than 700 mm.

5.5.5 By derogation to the height requirements mentioned in paragraphs 5.5.2 and 5.5.3.1 above, the height of any head restraint designed to be provided in rear centre seats or seating positions shall be not less than 700 mm.

5.6 In the case of a seat capable of being fitted with a head restraint, the provisions of paragraphs 5.1.3 and 5.4.2 above shall be verified.

5.6.1 The height of the part of the device on which the head rests, measured as described in 6.5 below, shall in the case of a head restraint adjustable for height be not less than 100 mm.

5.7 There shall be no gap of more than 60 mm between the seat-back and the head restraint in the case of a device not adjustable for height. If the head restraint is adjustable for height it shall, in its lowest position, be not more than 25 mm from the top of the seat-back. In the case of seats or bench seats adjustable in height provided with separate head restraints, this requirement shall be verified for all the positions of the seat or bench seat.

5.8 In the case of head restraints integral with the seat-back, the area to be considered is above a plane perpendicular to the reference line at 540 mm from the R point.

Between two vertical longitudinal planes passing at 85 mm on either side of the reference line. In this area, one or more gaps which regardless of their shape can show a distance "a" of more than 60 mm when measured as described in 6.7 below, are permitted provided that, after the additional test under 6.4.3.3.2 below, the requirements of paragraph 5.11 below are still met.

5.9 In the case of head restraints adjustable for height one or more gaps, which regardless of their shape can show a distance "a" of more than 60 mm when measured as described in 6.7 below, are permitted on the part of the device serving as a head restraint provided that, after the additional test under 6.4.3.3.2 below, the requirements of paragraph 5.11 below are still met.

5.10 The width of the head restraint shall be such as to provide appropriate support for the head of a person normally seated. As determined according to the procedure described in 6.6 below, the head restraint shall cover an area extending not less than 85 mm to each side of the vertical median plane of the seat for which the head restraint is intended.

5.11 The head restraint and its anchorage shall be such that the maximum backward displacement X of the head permitted by the head restraint and measured in conformity with the static procedure laid down in 6.4.3 below, is less than 102 mm.

5.12 The head restraint and its anchorage shall be strong enough to bear without breakage the load specified in 6.4.3.6 below. In the case of head restraints integral with the seat-back, the requirements of this paragraph shall apply to the part of the seat-back structure situated above a plane perpendicular to the reference line at 540 mm from the R point.

5.13 If the head restraint is adjustable, it shall not be possible to raise it beyond the maximum operational height except by deliberate action on the part of the user distinct from any act necessary for its adjustment.

5.14 The strength of the seat-back and of its locking devices is deemed to meet the requirements set out in 6.2 below when, after testing in accordance with 6.4.3.6 below, no breakage of the seat or seat-back has occurred; otherwise, it shall be shown that the seat is capable of meeting the test requirements set out in 6.2 below.

5.15 Special requirements regarding the protection of occupants from displaced luggage

5.15.1 Seat-backs

Seat-backs and/or head restraints located such that they constitute the forward boundary of the luggage compartment, all seats being in place and in the normal position of use as indicated by the manufacturer, shall have sufficient strength to protect the occupants from displaced luggage in a frontal impact. This requirement is deemed to be met if, during and after the test described in annex 9, the seat-backs remain in position and the locking mechanisms remain in place. However, the deformation of the seat-backs and their fastenings during the test is permitted, provided that the forward contour of the parts of the tested seat-back and/or head restraints, that are harder than 50 Shore A, does not move forward of a transverse vertical plane which passes through:

- (a) a point of 150 mm forward of the R point of the seat in question, for the parts of the head restraint;
- (b) a point of 100 mm forward of the R point of the seat in question, for parts of the seat-back;

excluding the rebound phases of the test blocks.

For integrated head restraints, the limit between the head restraint and the seat-back is defined by the plane perpendicular to the reference line 540 mm from the R point.

All measurements shall be taken in the longitudinal median plane of the corresponding seat or seating position for each seating position constituting the forward boundary of the luggage compartment.

During the test described in annex 9, the test blocks shall remain behind the seat-back(s) in question.

5.15.2 Partitioning systems

At the request of the vehicle manufacturer, the test described in annex 9 may be carried out with the partitioning systems in place, if these systems are fitted as standard equipment for the particular type of vehicle.

Partitioning systems, netting wire mesh located above the seat-backs in their normal position of use, shall be tested according to 2.2 of annex 9.

This requirement is deemed to be met if, during the test, the partitioning systems remain in position. However, the deformation of the partitioning systems during the test is permitted, provided that the forward contour of the partitioning (including parts of the tested seat-back(s) and/or head restraint(s) that are harder than 50 Shore A does not move forward of a transverse vertical plane which passes through:

- (a) a point of 150 mm forward of the R point of the seat in question, for parts of the head restraint;
- (b) a point of 100 mm forward of the R point of the seat in question, for parts of the seat-back and part of the partitioning system others than the head restraint.

For integrated head restraint, the limit between the head restraint and the seat-back is the one defined in paragraph 5.15.1.

All measurements shall be taken in the longitudinal median plane of the corresponding seat or seating position for each seating position constituting the forward boundary of the luggage compartment.

After the test, no sharp or rough edges likely to increase the danger or severity of injuries of the occupants shall be present.

5.15.3 The requirements mentioned in 5.13.1 and 5.13.2 above shall not apply to luggage retention systems which are activated automatically in case of an impact. The manufacturer shall demonstrate to the satisfaction of the technical service that the protection offered by such systems is equivalent to that described in paragraphs 5.15.1 and 5.15.2.

6 Tests

6.1 General specifications applicable to all tests

6.1.1 The seat-back, if adjustable, shall be locked in a position corresponding to a rearward inclination as close as possible to 25° from the vertical of the torso reference line of the manikin described in annex 3, unless otherwise specified by the manufacturer.

6.1.2 When a seat, its locking mechanism and its installation are identical or symmetrical with respect to another seat on the vehicle, the technical service may test only one such seat.

6.1.3 In the case of seats with adjustable head restraints, the tests shall be conducted with the head restraints placed in the most unfavourable position (generally, the highest position) allowed by its adjusting system.

6.2 Test of strength of the seat-back and its adjustment systems

6.2.1 A force producing a moment of 53 daNm in relation to the R point shall be applied longitudinally and rearwards to the upper part of the seat-back frame through a component simulating the back of the manikin shown in annex 3 to this Regulation. In the case of a bench seat, where part or all of the supporting frame (including that of the head restraints) is common to more than one seating position, the test shall be conducted simultaneously for all those seating positions.

6.3 Test of strength of the seat anchorage and the adjustment, locking and displacement systems

6.3.1 A longitudinal horizontal deceleration of not less than 20 g shall be applied for 30 milliseconds in the forward direction to the whole shell of the vehicle, in accordance with the requirements of annex 7, paragraph 1. At the request of the manufacturer the test pulse described in annex 9 - appendix, may be used alternatively.

6.3.2 A longitudinal deceleration in accordance with the requirements of paragraph 6.3.1 shall be applied in the rearward direction.

6.3.3 The requirements of paragraphs 6.3.1 and 6.3.2 above shall be verified for all positions of the seat. In the case of seats fitted with an adjustable head restraint, the test shall be conducted with the head restraints placed in the most unfavourable position (generally the highest position) allowed by its adjusting system. During the test the seat shall be so positioned that no external factor shall prevent the release of the locking systems.

These conditions shall be considered to be met if the seat is tested after being adjusted in the following positions:

- the longitudinal adjustment is fixed one notch or 10 mm rearward of the most forward normal driving position or position of use as indicated by the manufacturer (for seats with independent vertical adjustment, the cushion shall be placed in its highest position);
- the longitudinal adjustment is fixed one notch or 10 mm forward of the most rearward normal driving position or position of use as indicated by the manufacturer (for seats with independent vertical adjustment, the cushion shall be placed in its lowest position), and, where appropriate, in accordance with the requirements of paragraph 6.3.4 below.

6.3.4 In cases where the arrangement of the locking systems is such that, in a seat position other than those defined in paragraph 6.3.3 above, the distribution of the forces on the locking devices and seat anchorages would be less favourable than with either configuration defined in paragraph 6.3.3, the tests shall be conducted for that less favourable seating position.

6.3.5 The test conditions of 6.3.1 shall be considered to be satisfied if, at the request of the manufacturer, they are replaced by a collision test of the complete vehicle in running order against a rigid barrier as laid down in 2 of annex 7 to this Regulation. In this case, the seat shall be adjusted for the least favourable conditions of distribution of stresses in the anchorage system as provided for in 6.1.1, 6.3.3 and 6.3.4 above.

6.4 Test of the performance of the head restraint

6.4.1 If the head restraint is adjustable, it shall be placed in the most unfavourable position (generally the highest position) allowed by its adjustment system.

6.4.2 In the case of a bench seat, where part or all of the supporting frame (including that of the head restraints) is common to more than one seating position, the test shall be conducted simultaneously for all those seating positions.

6.4.3 Test

6.4.3.1 All lines, including the projections of the reference line, shall be drawn in the vertical median plane of the seat or seating position concerned (see annex 5 to this Regulation).

6.4.3.2 The displaced reference line is determined by applying to the part simulating the back of the manikin referred to in annex 3 to this Regulation an initial force producing a rearward moment of 37.3 daNm about the R point.

6.4.3.3 By means of a spherical headform 165 mm in diameter an initial force producing a moment of 37.3 daNm about the R point is applied at right angles to the displaced reference line at a distance of 65 mm below the top of the head restraint, the reference line being kept in its displaced position in accordance with paragraph 6.4.3.2.

6.4.3.3.1 If the presence of gaps prevents the application of the force prescribed in paragraph 6.4.3.3 at 65 mm from the top of the head restraint, the distance may be reduced so that the axis of the force passes through the centre line of the frame element nearest to the gap.

6.4.3.3.2 In the cases described in paragraphs 5.8 and 5.9 above, the test shall be repeated by applying to each gap, using a sphere of 165 mm in diameter, a force:

- passing through the centre of gravity of the smallest of the sections of the gap, along transversal planes parallel to the reference line, and
- reproducing a moment of 37.3 daNm about the R point.

6.4.3.4 The tangent Y to the spherical headform, parallel to the displaced reference line, is determined.

6.4.3.5 The distance X, provided for in paragraph 5.11 above, between the tangent Y and the displaced reference line is measured.

6.4.3.6 To check the effectiveness of the head restraint, the initial load specified in paragraphs 6.4.3.3 and 6.4.3.3.2 is increased to 89 daN unless the breakage of the seat or seat-back occurs earlier.

6.5 Determination of the height of the head restraint

6.5.1 All lines, including the projection of the reference line, shall be drawn in the vertical median plane of the seat or seating position concerned, the intersection of such plane with the seat determining the contour of the head restraint and of the seat-back (see figure 1 of annex 4 to this Regulation).

6.5.2 The manikin described in annex 3 to this Regulation shall be placed in a normal position on the seat.

6.5.3 The projection of the reference line of the manikin shown in annex 3 to this Regulation is then, in the seat concerned, drawn in the plane specified in paragraph 6.4.3.1 above.

The tangent S to the top of the head restraint is drawn perpendicular to the reference line.

6.5.4 The distance "h" from the R point to the tangent S is the height to be taken into consideration in implementing the requirements of paragraph 5.5 above.

6.6 Determination of the width of the head restraint (see figure 2 of annex 4 to this Regulation)

6.6.1 The plane S1, perpendicular to the reference line and situated 65 mm below the tangent S defined in paragraph 6.5.3 above, determines a section in the head restraint bounded by the outline C.

6.6.2 The width of the head restraint to be taken into consideration in implementing the requirements of paragraph 5.10 above, is the distance "L" measured in the plane S1 between the vertical longitudinal planes P and P'.

6.6.3 The width of the head restraint shall if necessary also be determined in the plane perpendicular to the reference line 635 mm above the R point of the seat, this distance being measured along the reference line.

6.7 Determination of distance "a" of head restraint gaps (see annex 8 to this Regulation)

6.7.1 The distance "a" shall be determined for each gap and in relation to the front face of the head restraint, by means of a sphere having a diameter of 165 mm.

6.7.2 The sphere shall be put into contact with the gap in a point of the gap area which allows the maximum sphere intrusion, considering no load is to be applied.

6.7.3 The distance between the two points of contact of the sphere with the gap will constitute the distance "a" to be considered for the evaluation of the provisions under paragraphs 5.8 and 5.9 above.

6.8 Tests for checking energy dissipation on the seat-back and head restraint

6.8.1 The surfaces of the rear parts of seats to be checked are those situated in the areas defined below which can be contacted by a 165 mm diameter sphere when the seat is mounted in the vehicle.

6.8.1.1 Area 1

6.8.1.1.1 In the case of separate seats without head restraints, this area shall include the rear part of the seat-back between the longitudinal vertical planes situated at 100 mm on either side of the longitudinal median plane of the seat centre line, and above a plane perpendicular to the reference line 100 mm below the top of the seat-back.

6.8.1.1.2 In the case of bench seats without head restraints, this area shall extend between the longitudinal vertical planes situated at 100 mm on either side of the longitudinal median plane of each

designated outboard seating position defined by the manufacturer and above a plane perpendicular to the reference line 100 mm below the top of the seat-back.

6.8.1.1.3 In the case of seats or bench seats with head restraints, this area shall extend between the longitudinal vertical planes, on either side of and 70 mm from the longitudinal median plane of the seat or of the seating position concerned and situated above the plane perpendicular to the reference line 635 mm from the R point. For the test, the head restraint, if adjustable shall be placed in the most unfavourable position (generally the highest) permitted by its adjustment system.

6.8.1.2 Area 2

6.8.1.2.1 In the case of seats or bench seats without head restraints and seats or bench seats with detachable or separate head restraints, area 2 shall extend above a plane perpendicular to the reference line 100 mm distant from the top of the seat-back, other than parts of area 1.

6.8.1.2.2 In the case of seats or bench seats with integrated head restraints, area 2 shall extend above a plane perpendicular to the reference line 440 mm distant from the R point of the seat or of the seating position concerned, other than parts of area 1.

6.8.1.3 Area 3

6.8.1.3.1 Area 3 is defined as the part of the back of the seat or the bench seats situated above the horizontal planes defined in paragraph 5.1.4.1.3 above, excluding parts situated in area 1 and area 2.

6.9 Equivalent test methods

If a test method other than those specified in paragraphs 6.2, 6.3, 6.4 above and annex 6 is used, its equivalence shall be proved.

7 Conformity of production

The conformity of production procedures shall comply with those set out in the Agreement, appendix 2 (E/ECE/324-E/ECE/TRANS/505/Rev.2), with the following requirements:

7.1 Every vehicle approved pursuant to this Regulation shall be so manufactured as to conform to the type approved by meeting the requirements set out in paragraph 5 above. However, in the case of head restraints as defined in paragraph 2.12.2 and 2.12.3 above, nothing shall prevent the vehicle from conforming to the vehicle type approved, even if it is marketed with seats not fitted with head restraints.

7.2 The competent authority which granted type approval may at any time verify the conformity control methods applied for each production unit. The authority may also carry out random checks on serially-manufactured vehicles in respect to the requirements set out in paragraph 5 above.

8 Penalties for non-conformity of production

8.1 The approval granted in respect of a vehicle type pursuant to this Regulation may be withdrawn if the requirements laid down in paragraph 7.1 above are not complied with or if the vehicles fail in the checks prescribed in paragraph 7 above.

8.2 If a Party to the Agreement applying this Regulation withdraws an approval it has previously granted, it shall forthwith so notify the other Contracting Parties applying this Regulation by means of a communication form conforming to the model in annex 1 to this Regulation.

9 Modifications of the vehicle type and extension of approval with respect to the seats, their anchorages and/or their head restraints

9.1 Every modification of the vehicle type with respect to the seats, their anchorages and/or their head restraints shall be notified to the administrative department which approved the vehicle type. The department may then either:

9.1.1 Consider that the modifications made are unlikely to have an appreciable adverse effect, and that in any event the vehicle still complies with the requirements; or

9.1.2 Consider that the modifications are sufficiently unimportant for the results specified in paragraph 6.2, 6.3 and 6.4 above to be verified by calculations based on the approval test results; or

9.1.3 Require a further report from the technical service responsible for conducting the tests.

9.2 Confirmation or refusal of approval, specifying the modifications, shall be communicated to the Parties to the Agreement applying this Regulation by means of the procedure laid down in paragraph 4.3 above.

9.3 The competent authority issuing the extension of approval shall assign a series number for such an extension and inform thereof the other Parties to the 1958 Agreement applying this Regulation by means of a communication form conforming to the model in annex 1 to this Regulation.

10 Production definitely discontinued

10.1 If the holder of the approval completely ceases to manufacture a device approved in accordance with this Regulation, he shall so inform the authority which granted the approval. Upon receiving the relevant communication that authority shall inform thereof the other Parties to the 1958 Agreement applying this Regulation by means of a communication form conforming to the model in annex 1 to this Regulation.

11 Instructions for use

11.1 For seats fitted with adjustable head restraints, the manufacturers shall provide instructions on how to operate, adjust, lock and, where applicable, remove the head restraints.

12 Names and addresses of technical services responsible for conducting approval tests and of administrative departments

The Parties to the Agreement applying this Regulation shall communicate to the United Nations Secretariat the names and addresses of the technical services responsible for conducting approval tests and of the administrative departments which grant approval and to which forms certifying approval or extension or refusal or withdrawal of approval, issued in other countries, are to be sent.

13 Transitional provisions

13.1 As from the official date of entry into force of the 06 series of amendments, no Contracting Party applying this Regulation shall refuse to grant ECE approvals under this Regulation as amended by the 06 series of amendments.

13.2 As from 1 October 1999, Contracting Parties applying this Regulation shall grant ECE approvals only if the requirements of this Regulation, as amended by the 06 series of amendments, are satisfied.

13.3 As from 1 October 2001, Contracting Parties applying this Regulation may refuse to recognize approvals which were not granted in accordance with the 06 series of amendments to this Regulation.

13.4 As from the official date of entry into force of the 07 series of amendments, no Contracting Party applying this Regulation shall refuse to grant ECE approvals under this Regulation as amended by the 07 series of amendments.

13.5 As from 24 months after the date of entry into force of the 07 series of amendments, Contracting Parties applying this Regulation shall grant ECE approval only if the vehicle type to be approved complies with the requirements of this Regulation as amended by the 07 series of amendments.

13.6 As from 48 months after the date of entry into force of the 07 series of amendments, existing approvals to this Regulation shall cease to be valid, except in the case of vehicle types which comply with the requirements of this Regulation as amended by the 07 series of amendments.

Annex 1

Communication

(maximum format: A4 (210 x 297 mm))

issued by: Name of administration:
.....
.....
.....



concerning: 2/ APPROVAL GRANTED
APPROVAL EXTENDED
APPROVAL REFUSED
APPROVAL WITHDRAWN
PRODUCTION DEFINITELY DISCONTINUED

of a vehicle type with regard to the strength of the seats and their anchorages, in the case either of seats fitted or capable of being fitted with head restraints or of seats not capable of being fitted with such devices and the characteristics of head restraints pursuant to Regulation No. 17

Approval No. Extension No.

- 1. Trade name or mark of the motor vehicle
2. Vehicle type
3. Manufacturer's name and address
4. If applicable, name and address of the manufacturer's representative
.....
5. Description of seats
6. Number of seats fitted or capable of being fitted with head restraints, adjustable or not adjustable
.....
7. Description of the adjustment, displacement and locking systems of the seat or of its parts and a description of occupant protection system against displacement of luggage
.....
8. Description of seat anchorage
9. Longitudinal position of the seats during the tests
10. Vehicle submitted for approval on
11. Technical service responsible for conducting approval tests
12. Date of report issued by that service
13. No. of report issued by that service

- 14. Remarks
- 15. Approval is granted/refused/extended/withdrawn 2/
- 16. Reason(s) of extension (if applicable)
- 17. Position of approval mark on the vehicle
- 18. Place
- 19. Date
- 20. Signature
- 21. The following documents, bearing the approval number shown above, are annexed to this communication:
 - ... drawings, diagrams and plans of the seats, their anchorage on the vehicle, the adjustment and displacement systems of the seats and their parts, and their locking devices;
 - ... photographs of the seats, their anchorages, the adjustment and displacement systems of the seats and their parts, and their locking devices, and of additional occupant protection system against displacement of luggage.

NOTE In the case of seats fitted with head restraints as defined in paragraphs 2.12.2 and 2.12.3 of this Regulation, the head restraint shall be shown on all drawings, diagrams and photographs.

1/ Distinguishing number of the country which has/granted/extended/ refused/withdrawn approval (see approval provisions in the Regulation).

2/ Strike out what does not apply.

Annex 2

Arrangements of approval marks

Model A

(see paragraphs 4.4., 4.4.1., 4.4.2. and 4.4.3. of this Regulation)

Vehicle with at least one seat fitted or capable of being fitted with a head restraint



$a = 8 \text{ mm min}$

The above approval mark when affixed to a vehicle shows that the vehicle type concerned, with regard to the strength of the seats fitted or capable of being fitted with head restraints and with regard to characteristics of the head restraints, has been approved in the Netherlands (E4) pursuant to Regulation No. 17, under the approval number 072439. The first two digits of the approval number indicate that the Regulation already contained the 07 series of amendments at the time of approval. The above approval mark also shows that the vehicle type was approved pursuant to Regulation No. 17 with regard to the strength of any seats on the vehicle which are not fitted or capable of being fitted with head restraints.

Model B

(see paragraphs 4.4.; 4.4.1. and 4.4.2. of this Regulation)

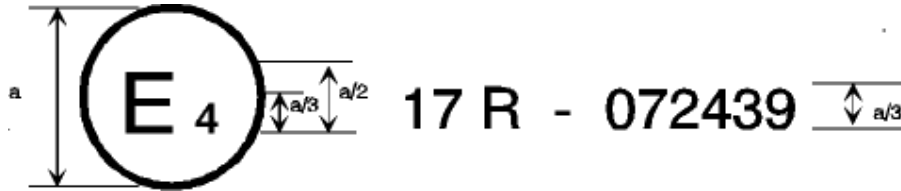
Vehicle with seats not fitted or not capable
of being fitted with head restraints

a = 8 mm min

The above approval mark when affixed to a vehicle shows that the vehicle type has seats not fitted or capable of being fitted with head restraints, and has, with regard to the strength of the seats and their anchorages, been approved in the Netherlands (E4) pursuant to Regulation No. 17 under the approval number 072439. The first two digits of the approval number indicate that the Regulation already contained the 07 series of amendments at the time of approval.

Model C

(see paragraph 4.5. of this Regulation)

Vehicle with at least one seat fitted or capable of being fitted with a head restraint

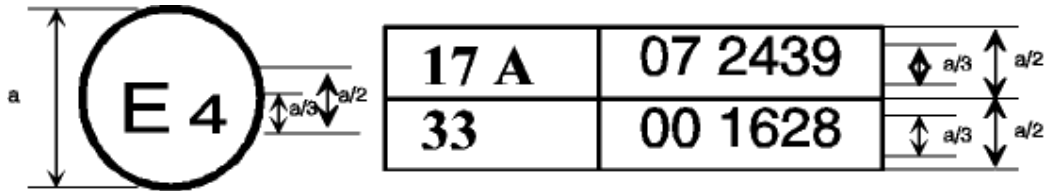

a = 8 mm min.

The above approval mark when affixed to a vehicle shows that the vehicle type has at least one seat fitted or capable of being fitted with a head restraint, and was approved in the Netherlands (E4) pursuant to Regulations Nos. 17 and 33. 1/

The approval numbers indicate that, on the dates when approval was granted, Regulation No. 17 included the 07 series of amendments but Regulation No. 33 was still in its original form. The above approval mark also shows that the vehicle type was approved pursuant to Regulation No. 17 with regard to the strength of any seats on the vehicle which are not fitted or capable of being fitted with head restraints.

Model D

(see paragraph 4.5. of this Regulation)

Vehicle with seats not fitted or not capable
of being fitted with head restraints

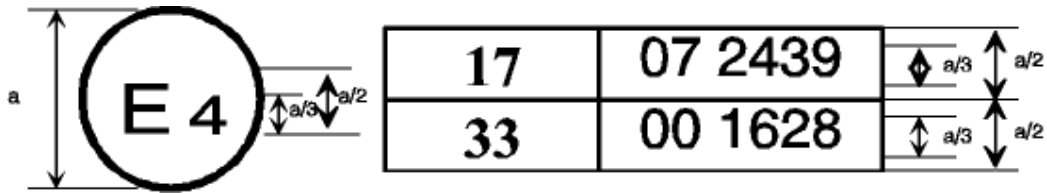

a = 8 mm min

The above approval mark when affixed to a vehicle shows that the vehicle type has seats not fitted or capable of being fitted with head restraints, and was approved in the Netherlands (E4) pursuant to Regulations Nos. 17 and 33. ^{1/} The approval numbers indicate that, on the dates when approval was granted, Regulation No. 17 included the 07 series of amendments but Regulation No. 33 was still in its original form.

^{1/} The second number is given merely as an example.

Annex 3

Procedure for determining the "H" point and the actual torso angle for seating positions in motor vehicles

1 Purpose

The procedure described in this annex is used to establish the "H" point location and the actual torso angle for one or several seating positions in a motor vehicle and to verify the relationship of measured data to design specifications given by the vehicle manufacturer. ^{5/}

2 Definitions

For the purposes of this annex:

2.1

"Reference data"

means one or several of the following characteristics of a seating position:

2.1.1

the "H" point and the "R" point and their relationship,

2.1.2

the actual torso angle and the design torso angle and their relationship.

2.2

"Three-dimensional 'H' point machine" (3-D H machine)

means the device used for the determination of "H" points and actual torso angles. This device is described in appendix 1 to this annex;

2.3

"'H' point"

means the pivot centre of the torso and thigh of the 3-D H machine installed in the vehicle seat in accordance with paragraph 4 below. The "H" point is located in the centre of the centreline of the device which is between the "H" point sight buttons on either side of the 3-D H machine. The "H" point corresponds theoretically to the "R" point (for tolerances see paragraph 3.2.2 below). Once determined in accordance with the procedure described in paragraph 4., the "H" point is considered fixed in relation to the seat-cushion structure and to move with it when the seat is adjusted;

2.4

"'R' point" or "seating reference point"

means a design point defined by the vehicle manufacturer for each seating position and established with respect to the three-dimensional reference system;

2.5

"Torso-line"

means the centreline of the probe of the 3-D H machine with the probe in the fully rearward position;

2.6

"Actual torso angle"

means the angle measured between a vertical line through the "H" point and the torso line using the back angle quadrant on the 3-D H machine. The actual torso angle corresponds theoretically to the design torso angle (for tolerances see paragraph 3.2.2. below);

^{5/} In any seating position other than front seats where the "H" point cannot be determined using the "three-dimensional 'H' point machine" or procedures, the "R" point indicated by the manufacturer may be taken as a reference at the discretion of the competent authority.

2.7**"Design torso angle"**

means the angle measured between a vertical line through the "R" point and the torso line in a position which corresponds to the design position of the seat-back established by the vehicle manufacturer;

2.8**"Centre plane of occupant" (C/LO)**

means the median plane of the 3-D H machine positioned in each designated seating position; it is represented by the co-ordinate of the "H" point on the "Y" axis. For individual seats, the centre plane of the seat coincides with the centre plane of the occupant. For other seats, the centre plane of the occupant is specified by the manufacturer;

2.9**"Three dimensional reference system"**

means a system as described in appendix 2 to this annex;

2.10**"Fiducial marks"**

are physical points (holes, surfaces, marks or indentations) on the vehicle body as defined by the manufacturer;

2.11**"Vehicle measuring attitude"**

means the position of the vehicle as defined by the co-ordinates of fiducial marks in the three-dimensional reference system.

3 Requirements**3.1 Data presentation**

For each seating position where reference data are required in order to demonstrate compliance with the provisions of the present Regulation, all or an appropriate selection of the following data shall be presented in the form indicated in appendix 3 to this annex:

3.1.1 The co-ordinates of the "R" point relative to the three-dimensional reference system;

3.1.2 The design torso angle;

3.1.3 All indications necessary to adjust the seat (if it is adjustable) to the measuring position set out in paragraph 4.3 below.

3.2 Relationship between measured data and design specifications

3.2.1 The co-ordinates of the "H" point and the value of the actual torso angle obtained by the procedure set out in paragraph 4. below shall be compared, respectively, with the co-ordinates of the "R" point and the value of the design torso angle indicated by the vehicle manufacturer.

3.2.2 The relative positions of the "R" point and the "H" point and the relationship between the design torso angle and the actual torso angle shall be considered satisfactory for the seating position in question if the "H" point, as defined by its co-ordinates, lies within a square of 50 mm side length with horizontal and vertical sides whose diagonals intersect at the "R" point, and if the actual torso angle is within 5 degree of the design torso angle.

3.2.3 If these conditions are met, the "R" point and the design torso angle, shall be used to demonstrate compliance with the provisions of this Regulation.

3.2.4 If the "H" point or the actual torso angle does not satisfy the requirements of paragraph 3.2.2 above, the "H" point and the actual torso angle shall be determined twice more (three times in all). If

the results of two of these three operations satisfy the requirements, the conditions of paragraph 3.2.3 above shall apply.

3.2.5 If the results of at least two of the three operations described in paragraph 3.2.4. above do not satisfy the requirements of paragraph 3.2.2. above, or if the verification cannot take place because the vehicle manufacturer has failed to supply information regarding the position of the "R" point or regarding the design torso angle, the centroid of the three measured points or the average of the three measured angles shall be used and be regarded as applicable in all cases where the "R" point or the design torso angle is referred to in this Regulation.

4 Procedure for "H" point and actual torso angle determination

4.1 The vehicle shall be preconditioned at the manufacturer's discretion, at a temperature of 20 ± 10 °C to ensure that the seat material reaches room temperature. If the seat to be checked has never been sat upon, a 70 to 80 kg person or device shall sit on the seat twice for one minute to flex the cushion and back. At the manufacturer's request, all seat assemblies shall remain unloaded for a minimum period of 30 minutes prior to installation of the 3-D H machine.

4.2 The vehicle shall be at the measuring attitude defined in paragraph 2.11 above.

4.3 The seat, if it is adjustable, shall be adjusted first to the rearmost normal driving or riding position, as indicated by the vehicle manufacturer, taking into consideration only the longitudinal adjustment of the seat, excluding seat travel used for purposes other than normal driving or riding positions. Where other modes of seat adjustment exist (vertical, angular, seat-back, etc.) these will be then adjusted to the position specified by the vehicle manufacturer. For suspension seats, the vertical position shall be rigidly fixed corresponding to a normal driving position as specified by the manufacturer.

4.4 The area of the seating position contacted by the 3-D H machine shall be covered by a muslin cotton, of sufficient size and appropriate texture, described as a plain cotton fabric having 18.9 threads per cm² and weighing 0.228 kg m² or knitted or non-woven fabric having equivalent characteristics.

If the test is run on a seat outside the vehicle, the floor on which the seat is placed shall have the same essential characteristics^{6/} as the floor of the vehicle in which the seat is intended to be used.

4.5 Place the seat and back assembly of the 3-D H machine so that the centre plane of the occupant (C/LO) coincides with the centre plane of the 3-D H machine. At the manufacturer's request, the 3-D H machine may be moved inboard with respect to the C/LO if the 3-D H machine is located so far outboard that the seat edge will not permit levelling of the 3-D H machine.

4.6 Attach the foot and lower leg assemblies to the seat pan assembly, either individually or by using the T-bar and lower leg assembly. A line through the "H" point sight buttons shall be parallel to the ground and perpendicular to the longitudinal centre plane of the seat.

4.7 Adjust the feet and leg positions of the 3-D H machine as follows:

4.7.1 Designated seating position: driver and outside front passenger.

4.7.1.1 Both feet and leg assemblies shall be moved forward in such a way that the feet take up natural positions on the floor, between the operating pedals if necessary. Where possible the left foot shall be located approximately the same distance to the left of the centre plane of the 3-D H machine as the right foot is to the right. The spirit level verifying the transverse orientation of the 3-D H machine is brought to the horizontal by readjustment of the seat pan if necessary, or by adjusting the leg and foot assemblies towards the rear. The line passing through the "H" point sight buttons shall be maintained perpendicular to the longitudinal centre plane of the seat.

^{6/} Tilt angle, height difference with a seat mounting, surface texture, etc.

4.7.1.2 If the left leg cannot be kept parallel to the right leg and the left foot cannot be supported by the structure, move the left foot until it is supported. The alignment of the sight buttons shall be maintained.

4.7.2 Designated seating position: outboard rear

For rear seats or auxiliary seats, the legs are located as specified by the manufacturer. If the feet then rest on parts of the floor which are at different levels, the foot which first comes into contact with the front seat shall serve as a reference and the other foot shall be so arranged that the spirit level giving the transverse orientation of the seat of the device indicates the horizontal.

4.7.3 Other designated seating positions:

The general procedure indicated in paragraph 4.7.1 above shall be followed except that the feet shall be placed as specified by the vehicle manufacturer.

4.8 Apply lower leg and thigh weights and level the 3-D H machine.

4.9 Tilt the back pan forward against the forward stop and draw the 3-D H machine away from the seat-back using the T-bar. Reposition the 3-D H machine on the seat by one of the following methods:

4.9.1 If the 3-D H machine tends to slide rearward, use the following procedure. Allow the 3-D H machine to slide rearward until a forward horizontal restraining load on the T-bar is no longer required i.e. until the seat pan contacts the seat-back. If necessary, reposition the lower leg.

4.9.2 If the 3-D H machine does not tend to slide rearward, use the following procedure. Slide the 3-D H machine rearwards by applying a horizontal rearward load to the T-bar until the seat pan contacts the seat-back (see figure 2 of appendix 1 to this annex).

4.10 Apply a 100 ± 10 N load to the back and pan assembly of the 3-D H machine at the intersection of the hip angle quadrant and the T-bar housing. The direction of load application shall be maintained along a line passing by the above intersection to a point just above the thigh bar housing (see figure 2 of appendix 1 to this annex). Then carefully return the back pan to the seat-back. Care must be exercised throughout the remainder of the procedure to prevent the 3-D H machine from sliding forward.

4.11 Install the right and left buttock weights and then, alternately, the eight torso weights. Maintain the 3-D H machine level.

4.12 Tilt the back pan forward to release the tension on the seat-back. Rock the 3-D H machine from side to side through 10 degrees arc (5 degrees to each side of the vertical centre plane) for three complete cycles to release any accumulated friction between the 3-D H machine and the seat.

During the rocking action, the T-bar of the 3-D H machine may tend to diverge from the specified horizontal and vertical alignment. The T-bar must therefore be restrained by applying an appropriate lateral load during the rocking motions. Care shall be exercised in holding the T-bar and rocking the 3-D H machine to ensure that no inadvertent exterior loads are applied in a vertical or fore and aft direction.

The feet of the 3-D H machine are not to be restrained or held during this step. If the feet change position, they should be allowed to remain in that attitude for the moment.

Carefully return the back pan to the seat-back and check the two spirit levels for zero position. If any movement of the feet has occurred during the rocking operation of the 3-D H machine, they must be repositioned as follows:

Alternately, lift each foot off the floor the minimum necessary amount until no additional foot movement is obtained. During this lifting, the feet are to be free to rotate; and no forward or lateral loads are to be applied. When each foot is placed back in the down position, the heel is to be in contact with the structure designed for this.

CD/K/017:2008

Check the lateral spirit level for zero position; if necessary, apply a lateral load to the top of the back pan sufficient to level the 3-D H machine's seat pan on the seat.

4.13 Holding the T-bar to prevent the 3-D H machine from sliding forward on the seat cushion, proceed as follows:

- (a) return the back pan to the seat-back;
- (b) alternately apply and release a horizontal rearward load, not to exceed 25 N, to the back angle bar at a height approximately at the centre of the torso weights until the hip angle quadrant indicates that a stable position has been reached after load release. Care shall be exercised to ensure that no exterior downward or lateral loads are applied to the 3-D H machine. If another level adjustment of the 3-D H machine is necessary, rotate the back pan forward, re-level, and repeat the procedure from paragraph 4.12.

4.14 Take all measurements:

4.14.1 The co-ordinates of the "H" point are measured with respect to the three-dimensional reference system.

4.14.2 The actual torso angle is read at the back angle quadrant of the 3-D H machine with the probe in its fully rearward position.

4.15 If a re-run of the installation of the 3-D H machine is desired, the seat assembly should remain unloaded for a minimum period of 30 minutes prior to the re-run. The 3-D H machine should not be left loaded on the seat assembly longer than the time required to perform the test.

4.16 If the seats in the same row can be regarded as similar (bench seat, identical seats, etc.) only one "H" point and one "actual torso angle" shall be determined for each row of seats, the 3-D H machine described in appendix 1 to this annex being seated in a place regarded as representative for the row. This place shall be:

4.16.1 In the case of the front row, the driver's seat;

4.16.2 In the case of the rear row or rows, an outer seat.

Annex 3 - Appendix 1**Description of the three-dimensional "H" point machine ^{2/}**

(3-D H machine)

1 Back and seat pans

The back and seat pans are constructed of reinforced plastic and metal; they stimulate the human torso and thigh and are mechanically hinged at the "H" point. A quadrant is fastened to the probe hinged at the "H" point to measure the actual torso angle. An adjustable thigh bar, attached to the seat pan, establishes the thigh centreline and serves as a baseline for the hip angle quadrant.

2 Body and leg elements

Lower leg segments are connected to the seat pan assembly at the T-bar joining the knees, which is a lateral extension of the adjustable thigh bar. Quadrants are incorporated in the lower leg segments to measure knee angles. Shoe and foot assemblies are calibrated to measure the foot angle. Two spirit levels orient the device in space. Body element weights are placed at the corresponding centres of gravity to provide seat penetration equivalent to a 76 kg male. All joints of the 3-D H machine should be checked for free movement without encountering noticeable friction.

^{2/} For details of the construction of the 3-D H machine refer to Society of Automotive Engineers (SAE), 400 Commonwealth Drive, Warrendale, Pennsylvania 15096, United States of America.

The machine corresponds to that described in ISO Standard 6549 : 1980.

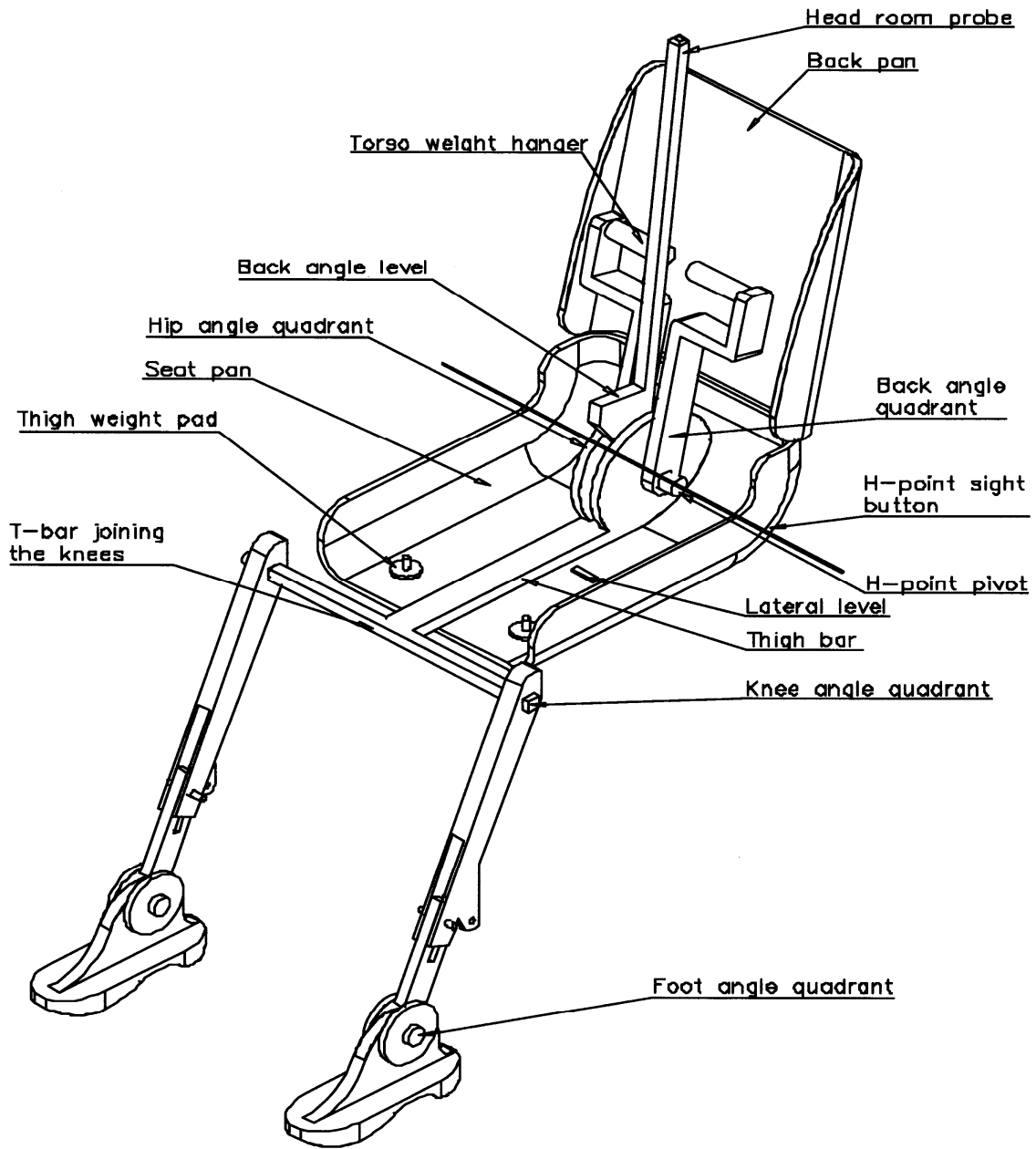

Figure 1 — 3-D H machine elements designation

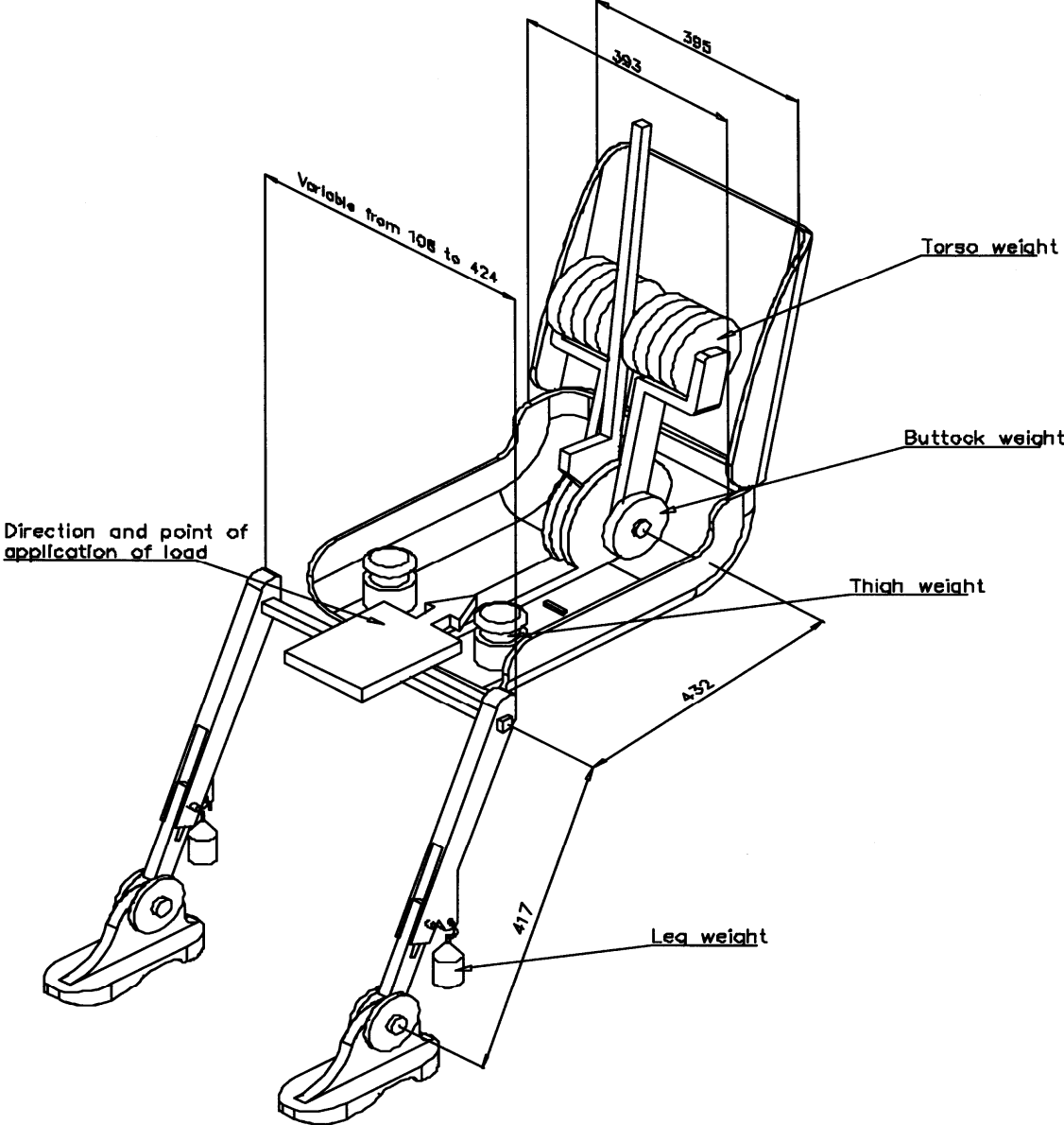

Figure 2 — Dimensions of the 3-D H machine elements and load distribution (Dimensions in millimeters)

Annex 3 - Appendix 2

Three-dimensional reference system

- 1 The three-dimensional reference system is defined by three orthogonal planes established by the vehicle manufacturer (see figure). ^{2/}
- 2 The vehicle measuring attitude is established by positioning the vehicle on the supporting surface such that the co-ordinates of the fiducial marks correspond to the values indicated by the manufacturer.
- 3 The co-ordinates of the "R" point and the "H" point are established in relation to the fiducial marks defined by the vehicle manufacturer.

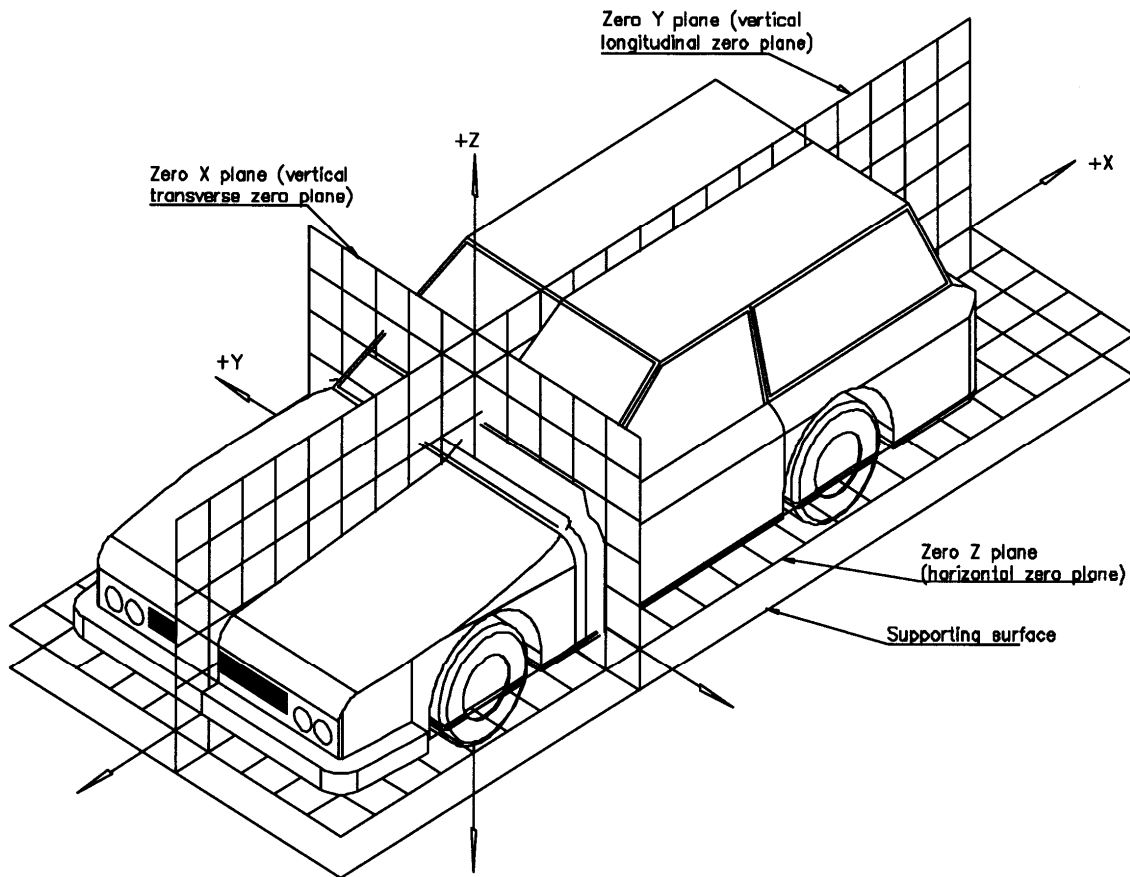

Figure — Three-dimensional reference system

^{2/} The reference system corresponds to ISO standard 4130 : 1978.

Annex 3 - Appendix 3**Reference data concerning seating positions****1 Coding of reference data**

Reference data are listed consecutively for each seating position. Seating positions are identified by a two-digit code. The first digit is an Arabic numeral and designates the row of seats, counting from the front to the rear of the vehicle. The second digit is a capital letter which designates the location of the seating position in a row, as viewed in the direction of forward motion of the vehicle; the following letters shall be used:

L = left
C = centre
R = right

2. Description of vehicle measuring attitude**2.1. Co-ordinates of fiducial marks**

X

Y

Z

3. List of reference data**3.1. Seating position:****3.1.1. Co-ordinates of "R" point**

X

Y

Z

3.1.2. Design torso angle:**3.1.3. Specification for seat adjustment ^{*/}**

horizontal:

vertical:

angular:

torso angle:

NOTE List reference data for further seating positions under 3.2., 3.3., etc.

^{*/} Strike out what does not apply.

Annex 4

Determination of the height and width of head restraints

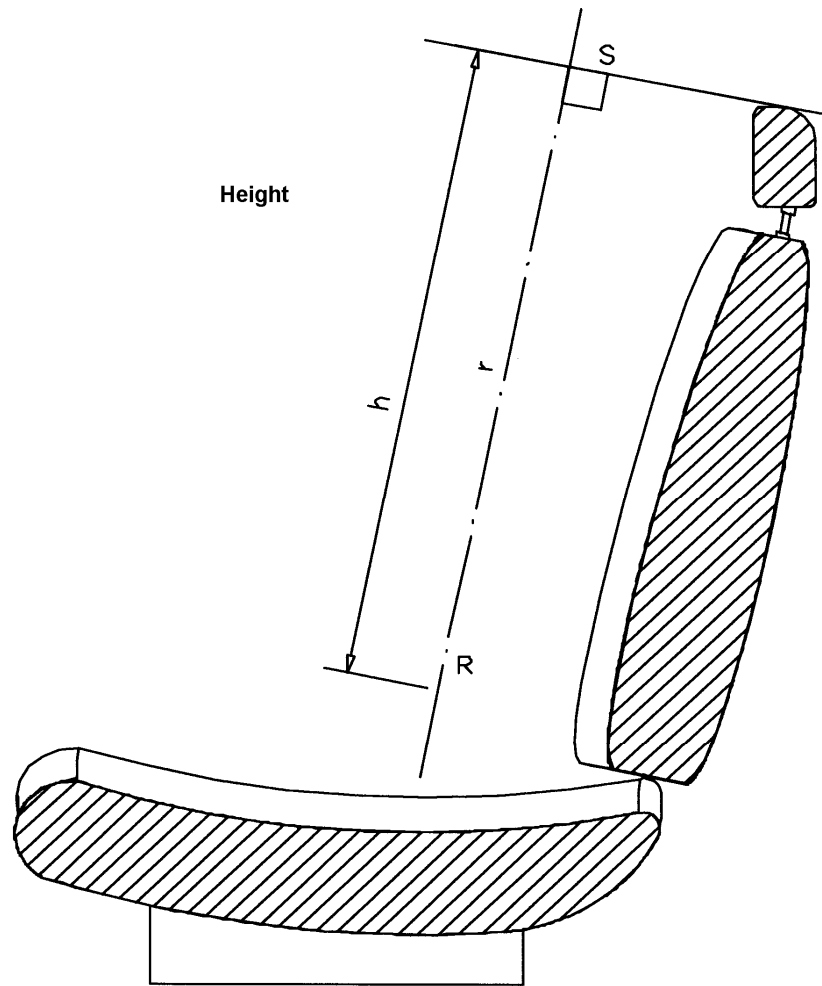

Figure 1

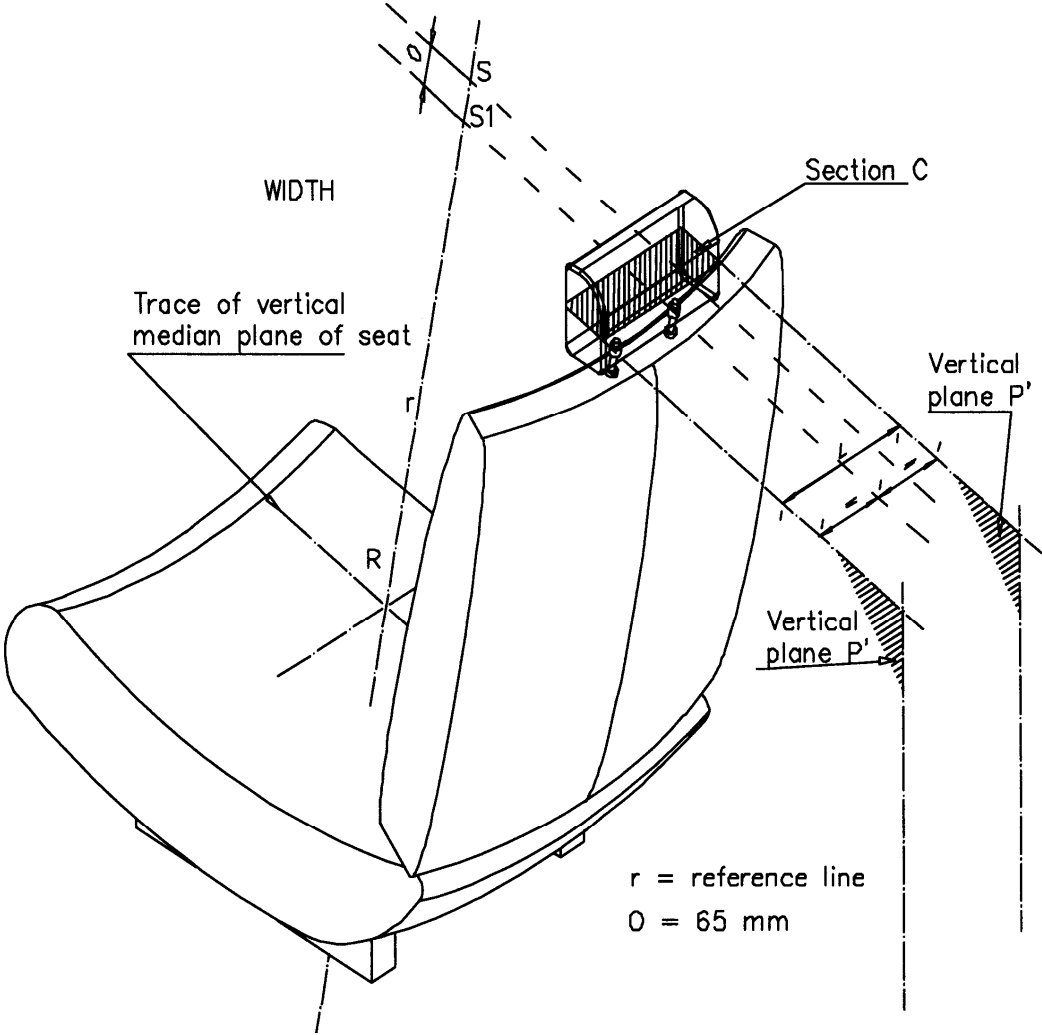
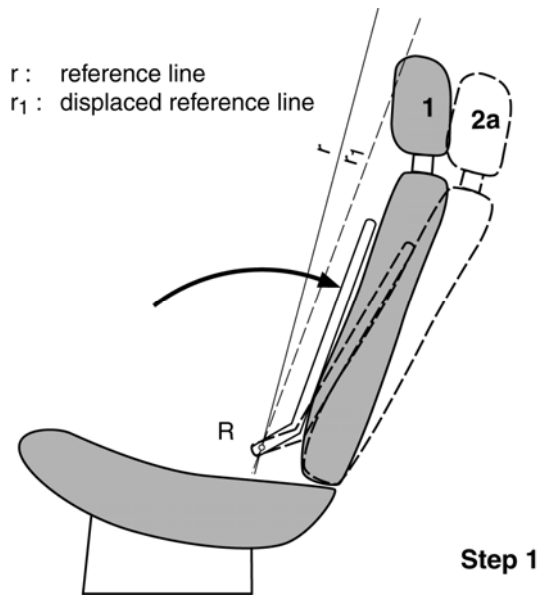

Figure 2

Annex 5

Details of lines and measurements taken during tests



1. Original unloaded position.
- 2a. Displaced position by applying to the manikin's back a moment of 373 Nm about the R point, defining the position of the displaced reference line r₁.
- 2b. Displaced position by applying to the 165 mm sphere a force F producing a moment of 373 Nm about the R point, keeping the displaced reference line r₁ in place.
3. Position after displacement by the force F increased to 890 N.

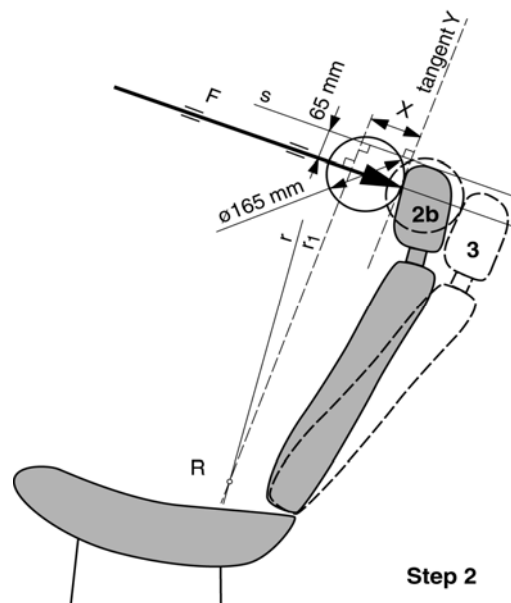

Annex 6

Test procedure for checking energy dissipation

1 Installation, test apparatus, recording instruments and procedure

1.1 Setting up

The seat, as mounted in the vehicle, shall be firmly secured to the test bench with the attachment parts provided by the manufacturer, so as to remain stationary when the impact is applied.

The seat-back, if adjustable, shall be locked in the position specified in paragraph 6.1.1 of this Regulation.

If the seat is fitted with a head restraint, the head restraint shall be mounted on the seat-back as in the vehicle. Where the head restraint is separate, it shall be secured to the part of the vehicle structure to which it is normally attached.

If the head restraint is adjustable, it shall be placed in the most unfavourable position allowed by its adjusting systems.

1.2 Test apparatus

1.2.1 This apparatus consists of a pendulum whose pivot is supported by ball-bearings and whose reduced mass ^{2/} at its centre of percussion is 6.8 kg. The lower extremity of the pendulum consists of a rigid headform 165 mm in diameter whose centre is identical with the centre of percussion of the pendulum.

1.2.2 The headform shall be fitted with two accelerometers and a speed-measuring device, all capable of measuring values in the direction of impact.

1.3 Recording instruments

The recording instruments used shall be such that measurements can be made with the following degrees of accuracy:

1.3.1 Acceleration:

- accuracy = ± 5 % of the actual value;
- frequency class of data channel: class 600 corresponding to ISO Standard 6487 (1980);
- cross-axis sensitivity = < 5 % of the lowest point on the scale.

1.3.2 Speed:

- accuracy: ± 2.5 % of the actual value;
- sensitivity: 0.5 km/h.

^{2/} The relationship of the reduced mass "m_r" of the pendulum to the total mass "m" of the pendulum at a distance "a" between the centre of percussion and the axis of rotation and at a distance "l" between the centre of gravity and the axis of rotation is given by the formula:

$$m_r = m \frac{l}{a}$$

1.3.3 Time recording:

- the instrumentation shall enable the action to be recorded throughout its duration and readings to be made to within one one-thousandth of a second;
- the beginning of the impact at the moment of first contact between the headform and the item being tested shall be detected on the recordings used for analysing the test.

1.4 Test procedure

1.4.1 Tests on the seat-back

With the seat installed as indicated in paragraph 1.1 of this annex, the direction of impact from the rear towards the front shall be situated in a longitudinal plane at an angle of 45° from the vertical.

The impact points shall be selected by the test laboratory in area 1 as defined in paragraph 6.8.1.1 of this Regulation, or if necessary in area 2 as defined in paragraph 6.8.1.2 of this Regulation, on surfaces exhibiting radii of curvature less than 5 mm.

1.4.2 Tests on the head restraint

The head restraint shall be fitted and adjusted as indicated in paragraph 1.1 of this annex. Impacts shall be performed on points selected by the test laboratory in area 1 as defined in paragraph 6.8.1.1 of this Regulation, and possibly in area 2 as defined in paragraph 6.8.1.2 of this Regulation, on surfaces exhibiting radii of curvature less than 5 mm.

1.4.2.1 For the rear face, the direction of impact from the rear towards the front shall be in a longitudinal plane at an angle of 45° from the vertical.

1.4.2.2 For the front face, the direction of impact from the front towards the rear shall be horizontal in a longitudinal plane.

1.4.2.3 The front and rear zones are respectively bounded by the horizontal plane tangential to the top of the head restraint as determined in paragraph 6.5. of this Regulation.

1.4.3 The headform shall strike the test item at a speed of 24.1 km/h: this speed shall be achieved either by the mere energy of propulsion or by using an additional impelling device.

2 Results

The deceleration rate shall be taken as the average of the readings on the two decelerometers.

3 Equivalent procedures (see paragraph 6.9. of this Regulation).

Annex 7

Method for testing the strength of seat anchorages and their adjustments, locking and displacement systems

1 Test of resistance to inertia effects

1.1 The seats to be tested shall be mounted on the vehicle body for which they are designed. This vehicle body shall be firmly anchored on a test trolley as prescribed in the following paragraphs.

1.2 The method used for anchoring the vehicle body on the test trolley shall not result in a reinforcement of the seat anchorages.

1.3 The seats and their parts shall be adjusted and locked as prescribed in paragraph 6.1.1 and in one of the positions described in paragraph 6.3.3 or 6.3.4 of this Regulation.

1.4 If the seats of a group do not present essential differences in the sense of paragraph 2.2 of this Regulation, the tests prescribed in paragraphs 6.3.1 and 6.3.2 of this Regulation may be carried out with one seat adjusted to its foremost position and the other seat adjusted to its rearmost position.

1.5 The trolley deceleration is measured with data channels of frequency class (CFC) 60 corresponding to the characteristics of International Standard ISO 6487 (1980).

2 Collision test of the complete vehicle against a rigid barrier

2.1 The barrier shall consist of a block of reinforced concrete of not less than 3 m width, not less than 1.5 m height and not less than 0.6 m thickness. The front face shall be perpendicular to the final part of the run-up track and shall be covered with plywood boards 19 ± 1 mm thick. At least 90 tonnes of earth shall be compressed behind the block of reinforced concrete. The barrier of reinforced concrete and earth may be replaced by obstacles having the same front surface, provided that they give equivalent results.

2.2 At the moment of impact the vehicle shall run free. It shall reach the obstacle on a course perpendicular to the collision wall; the maximum lateral misalignment allowed between the vertical median line of the front of the vehicle and the vertical median line of the collision wall shall be ± 30 cm; at the moment of impact the vehicle shall no longer be subjected to the action of any additional steering or propelling device. The speed on impact shall be between 48.3 km/h and 53.1 km/h.

2.3 The fuel feed system shall be filled to at least 90 per cent of its capacity with fuel or an equivalent liquid.

Annex 8

Determination of dimension “a” of head restraint gaps

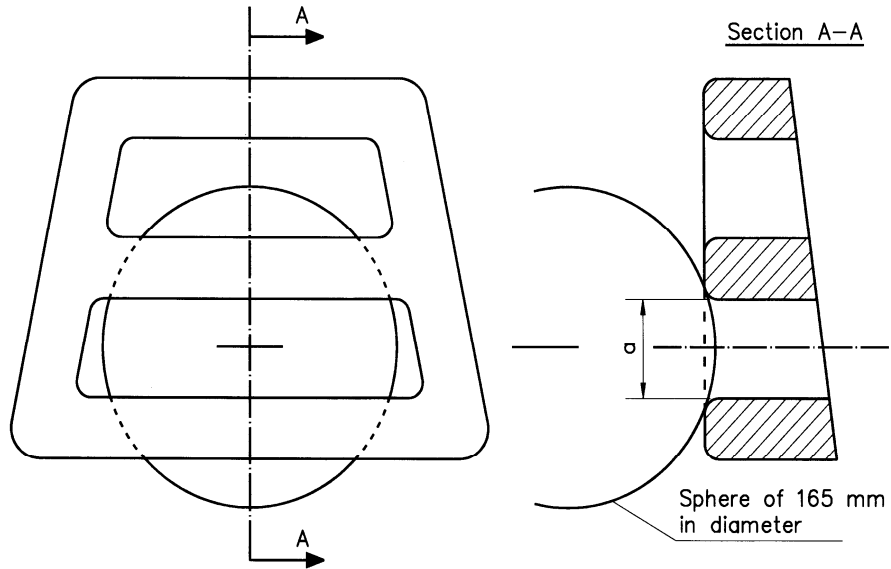

Figure 1 — Example of horizontal gaps

NOTE Section A-A is to be made in a point of the gap area which allows the maximum sphere intrusion, without exerting any load.

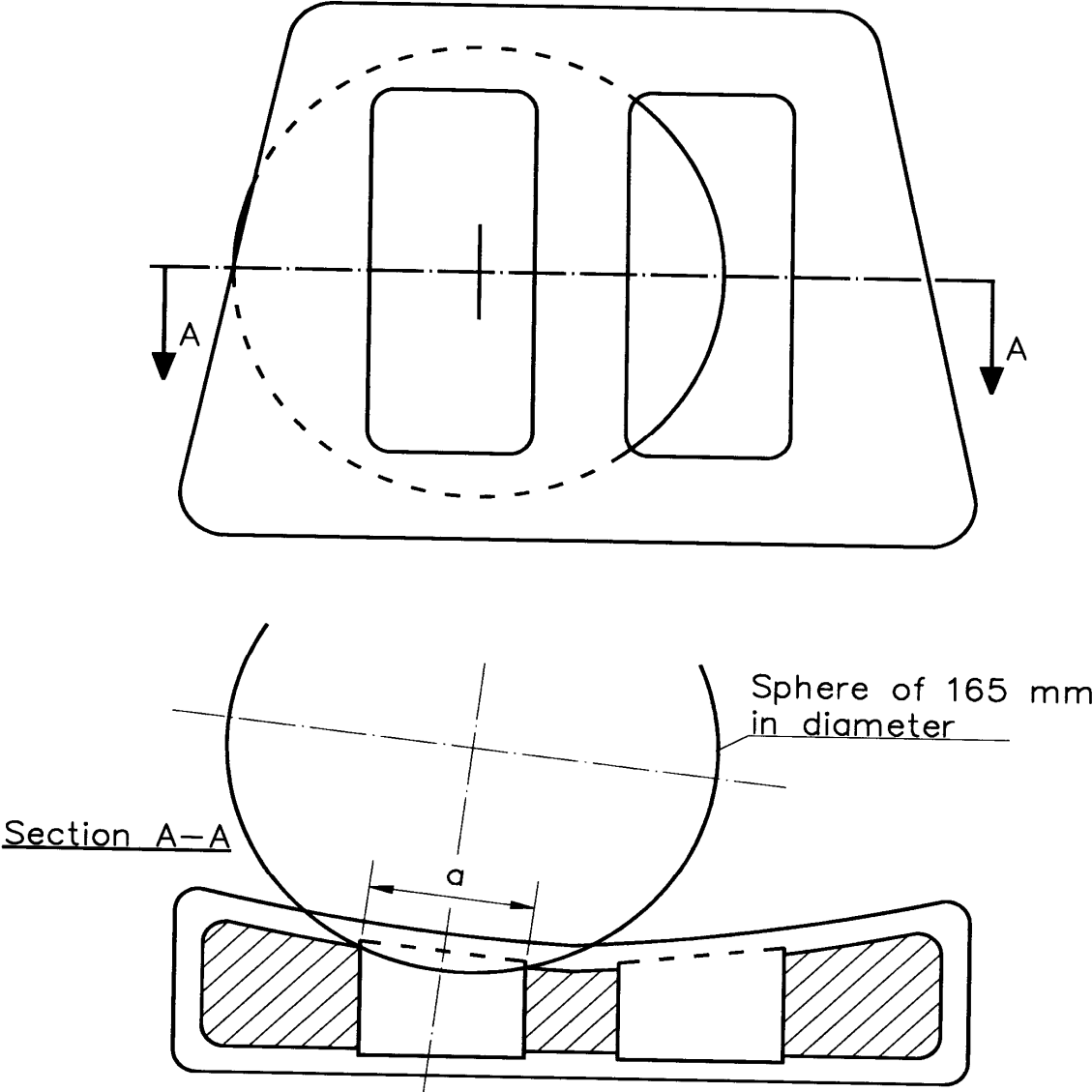

Figure 2 — Example of vertical gaps

NOTE Section A-A is to be made in a point of the gap area which allows the maximum sphere intrusion, without exerting any load.

Annex 9

Test procedure for devices intended to protect the occupants against displacement of luggage

1 Test blocks

Rigid blocks, with the centre of inertia in the geometric centre.

Type 1

Dimensions: 300 mm x 300 mm x 300 mm
all edges and corners rounded to 20 mm

Mass: 18 kg

Type 2

Dimensions: 500 mm x 350 mm x 125 mm
all edges and corners rounded to 20 mm

Mass: 10 kg

2 Test preparation

2.1 Test of seat-backs (see figure 1)

2.1.1 General requirements

2.1.1.1 At the option of the car manufacturer, parts whose hardness is lower than 50 Shore A can be removed from the tested seat and head restraint for the tests.

2.1.1.2 Two type 1 test blocks shall be placed on the floor of the luggage compartment. In order to determine the location of the test blocks in the longitudinal direction, they shall first be positioned such that their front side contacts that part of the vehicle which constitutes the forward boundary of the luggage compartment and that their lower side rests on the floor of the luggage compartment. They shall then be moved backwards and parallel to the longitudinal median plane of the vehicle until their geometrical centre has traversed a horizontal distance of 200 mm. If the dimensions of the luggage compartment do not allow a distance of 200 mm and if the rear seats are horizontally adjustable, these seats shall be moved forward to the limit of the adjustment range intended for normal occupant use, or to the position resulting in a distance of 200 mm, whichever is less. In other cases, the test blocks shall be placed as far as possible behind the rear seats. The distance between the longitudinal median plane of the vehicle and the inward facing side of each test block shall be 25 mm to obtain a distance of 50 mm between both blocks.

2.1.1.3 During the test, the seats must be adjusted to ensure that the locking system cannot be released by external factors. If applicable, the seats shall be adjusted as follows:

The longitudinal adjustment shall be secured one notch or 10 mm in front of the rearmost possible position of use specified by the manufacturer (for seats with independent vertical adjustment, the cushion shall be placed to its lowest possible position). The test shall be carried out with the seat-backs in their normal position of use.

2.1.1.4 If the seat-back is fitted with a head restraint, the test must be carried out with the head restraint placed in the highest position, if adjustable.

2.1.1.5 If the back(s) of the rear seat(s) can be folded down, they shall be secured in their upright normal position by the standard locking mechanism.

2.1.1.6 Seats behind which the type 1 blocks cannot be installed are exempted from this test

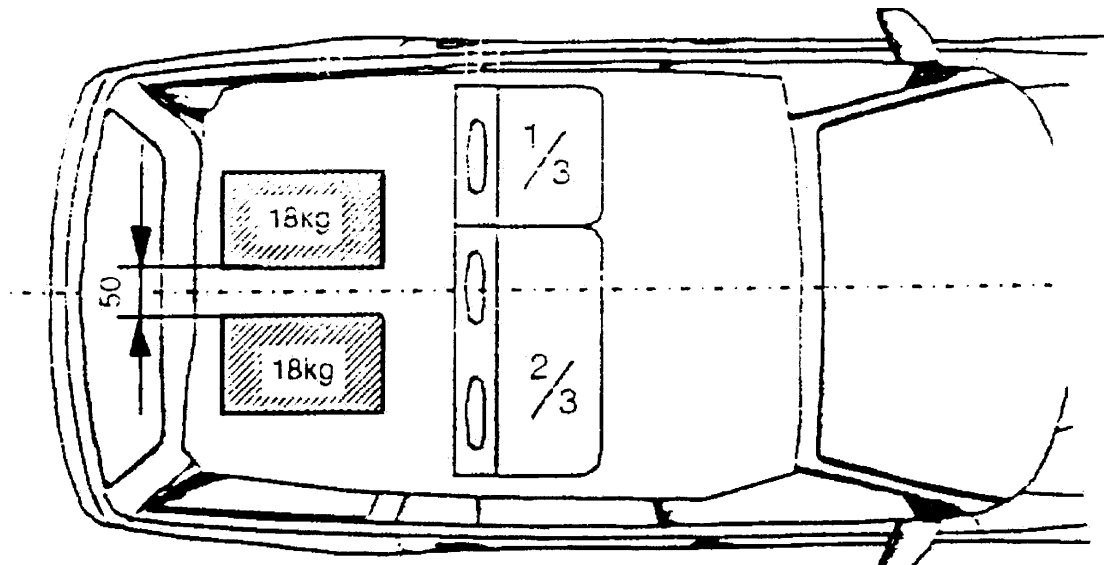

Figure 1 — Positions of test blocks before test of rear seat-backs

2.1.2 Vehicles with more than two rows of seats

2.1.2.1 If the rearmost row of seats is removable and/or can be folded down by the user according to the manufacturer's instructions in order to increase the luggage compartment area, then the seat row immediately in front of this rearmost row shall also be tested.

2.1.2.2 However, in this case, the Technical Service, after consultation with the manufacturer, may decide not to test one of the two rearmost rows of seats if the seats and their attachments are of similar design and if the test requirement of 200 mm is respected.

2.1.3 When there is a gap, allowing sliding of one type 1 block past the seats, then the test loads (two type 1 blocks) shall be installed behind the seats after agreement between the Technical Service and the manufacturer.

2.1.4 The exact test configuration shall be noted in the test report.

2.2 Test of partitioning systems

For the test of the partitioning systems above the seat-backs, the vehicle shall be fitted with a fixed raised test floor having a load surface that locates the centre of gravity of the test block centrally between the top edge of the bordering seat-back (without taking into account the head restraints) and the bottom edge of the roof lining. A type 2 test block is placed on the raised test floor with its largest surface 500 x 350 mm, centrally in relation to the longitudinal axis of the vehicle and with its surface 500 x 125 mm to the front. Partitioning systems behind which the type 2 test block cannot be installed are exempted from this test. The test block is placed directly in contact with the partitioning system. In addition, two type 1 test blocks are positioned in accordance with paragraph 2.1 in order to perform a simultaneous test on the seat-backs (see figure 2).

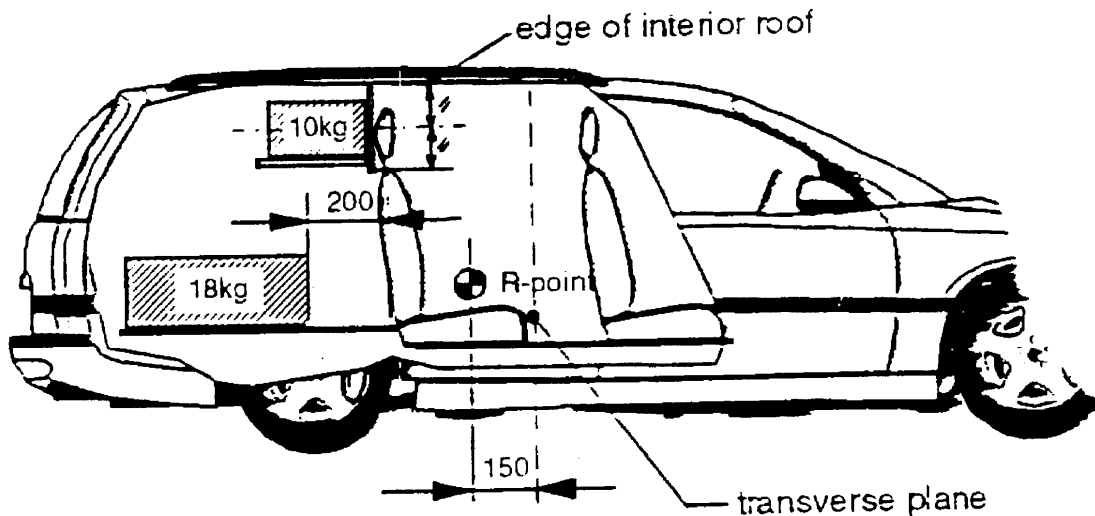

Figure 2 — Testing of a partitioning system above the backrest

2.2.1 If the seat-back is fitted with a head restraint, the test must be carried out with the head restraint placed in the highest position, if adjustable.

3 Dynamic testing of seat-backs and partitioning systems used as luggage restraint systems

3.1 The body of the passenger car shall be anchored securely to a test sled, and this anchorage shall not act as reinforcement for seat-backs and the partitioning system. After the installation of the test blocks as described in paragraph 2.1. or 2.2., the passenger car body shall be accelerated as shown in annex 9, appendix, so that at the moment of impact, its free running speed is 50 +0/-2 km/h. With the agreement of the manufacturer, the above described test pulse corridor can be used alternatively to fulfil the test of the seat strength according to paragraph 6.3.1.

Annex 9 — Appendix

Sled declaration corridor as a function of time (Frontal impact)

