



CD/K/014:2009
ICS 23.040.15

EAST AFRICAN STANDARD

Copper and copper alloys — Seamless, round copper tubes for water and gas in sanitary and heating applications

EAST AFRICAN COMMUNITY

Foreword

Development of the East African Standards has been necessitated by the need for harmonizing requirements governing quality of products and services in East Africa. It is envisaged that through harmonized standardization, trade barriers which are encountered when goods and services are exchanged within the Community will be removed.

In order to meet the above objectives, the EAC Partner States have enacted an East African Standardization, Quality Assurance, Metrology and Test Act, 2006 (EAC SQMT Act, 2006) to make provisions for ensuring standardization, quality assurance, metrology and testing of products produced or originating in a third country and traded in the Community in order to facilitate industrial development and trade as well as helping to protect the health and safety of society and the environment in the Community.

East African Standards are formulated in accordance with the procedures established by the East African Standards Committee. The East African Standards Committee is established under the provisions of Article 4 of the EAC SQMT Act, 2006. The Committee is composed of representatives of the National Standards Bodies in Partner States, together with the representatives from the private sectors and consumer organizations. Draft East African Standards are circulated to stakeholders through the National Standards Bodies in the Partner States. The comments received are discussed and incorporated before finalization of standards, in accordance with the procedures of the Community.

Article 15(1) of the EAC SQMT Act, 2006 provides that "Within six months of the declaration of an East African Standard, the Partner States shall adopt, without deviation from the approved text of the standard, the East African Standard as a national standard and withdraw any existing national standard with similar scope and purpose".

East African Standards are subject to review, to keep pace with technological advances. Users of the East African Standards are therefore expected to ensure that they always have the latest versions of the standards they are implementing.

© East African Community 2010 — All rights reserved*

East African Community

P O Box 1096

Arusha

Tanzania

Tel: 255 27 2504253/8

Fax: 255-27-2504481/2504255

E-Mail: eac@eachq.org

Web: www.each.int

Contents

1	Scope	1
2	Normative references.....	1
3	Terms and definitions.....	2
4	Designations.....	3
4.1	Material	3
4.2	Material condition	3
4.3	Product.....	3
5	Ordering information	4
6	Material characteristics	4
6.1	Safety in case of fire — Reaction to fire	4
6.2	Properties at high temperature	5
6.3	Weldability.....	5
7	Requirements	5
7.1	Composition	5
7.2	Mechanical properties	5
7.3	Dimensions and tolerances	7
7.4	Freedom from defects	9
7.5	Surface quality.....	9
7.6	Bending.....	10
7.7	Drift expanding	10
7.8	Flanging	10
8	Evaluation of conformity.....	11
8.1	General	11
8.2	Type testing.....	11
8.3	Factory production control (FPC).....	11
9	Sampling.....	13
10	Test methods.....	14
10.1	Analysis.....	14
10.2	Tensile test.....	14
10.3	Hardness test	14
10.4	Carbon content test.....	14
10.5	Carbon film test	14
10.6	Bending test.....	14
10.7	Drift-expanding test	15
10.8	Flanging test.....	15
10.9	Freedom from defects tests.....	15
10.10	Retests.....	15
11	Inspection documentation.....	15
12	Marking and form of delivery	15
12.1	Marking	15
12.2	Form of delivery.....	16
	Annex A (normative) Standardized dimensions for reconsideration at a future revision	17
	Annex B (normative) Carbon film test.....	18
	Annex C (normative) Freedom from defects tests	19
	Annex ZA (informative) Clauses of this European Standard addressing the provisions of the EU Construction Products Directive (CPD) 89/106/EEC	Error! Bookmark not defined.
	Annex ZB (informative) Relationship between this European Standard and the Essential Requirements of the EU Pressure Equipment Directive (PED) 97/23/EC	Error! Bookmark not defined.
	Bibliography	20

Introduction

This East African Standard provides the basis for the assessment of a manufacturer's production process for products manufactured in accordance with this East African Standard. The assessment could be based on initial and continuing surveillance of the factory production control system which could be concurrent with an assessment of the manufacturer's quality management system against ISO 9001.

Tubes having an outside diameter of not more than 108 mm are suitable for soldering, brazing or assembling by mechanical compression, collared, push-fit or press fittings. For tubes having an outside diameter of more than 108 mm, assembly should preferably be performed by welding or braze welding.

Reference can be made to this East African Standard for tubes intended for other applications or for the transportation of other fluids. In such cases special requirements (for specifications, conditioning or delivery conditions) can be agreed between the purchaser and the supplier.

NOTE Appropriate precautions should be taken if applying insulating/protecting material because it could be detrimental to the copper tube.

In the preparation of this East African Standard, the following source was consulted extensively:

BS EN 1057:2006, *Copper and copper alloys — Seamless, round copper tubes for water and gas in sanitary and heating applications*

Assistance derived from this source and others inadvertently not mentioned is hereby acknowledged.

Copper and copper alloys — Seamless, round copper tubes for water and gas in sanitary and heating applications

1 Scope

This East African Standard specifies the requirements, sampling, test methods and conditions of delivery for seamless round copper tubes.

It is applicable to tubes having an outside diameter from 6 mm up to and including 267 mm for:

- distributing networks for hot water and cold water;
- hot water heating systems, including panel heating systems (under-floor, wall, overhead);
- domestic gas and liquid fuel distribution;
- waste water sanitation.

It is also applicable to seamless round copper tubes intended to be pre-insulated before use for any of the above purposes.

2 Normative references

The following referenced documents are indispensable for the application of this document. For dated references, only the edition cited applies. For undated references, the latest edition of the referenced document (including any amendments) applies.

EN 723, *Copper and copper alloys — Combustion method for determination of carbon on the inner surface of copper tubes or fittings*

EN 1971, *Copper and copper alloys — Eddy current test for tubes*

EN 10002-1, *Metallic materials — Tensile testing — Part 1: Method of test at ambient temperature*

ISO 6892, *Metallic materials — Tensile testing at ambient temperature*

EN 10204:2004, *Metallic products — Types of inspection documents*

ISO 8491, *Metallic materials — Tube (in full section) — Bend test*

ISO 8493, *Metallic materials — Tube — Drift-expanding test*

ISO 8494, *Metallic materials — Tube — Flanging test*

ISO 6507-1, *Metallic materials — Vickers hardness test—Part 1: Test method*

ISO 9001, *Quality management systems — Requirements*

ISO 1553, *Unalloyed copper containing not less than 99.90 % of copper — Determination of copper content — Electrolytic method*

ISO 4741, *Copper and copper alloys — Determination of phosphorus content — Molybdovanadate spectrometric method*

NOTE Informative references to documents used in the preparation of this standard, and cited at the appropriate places in the text, are listed in the Bibliography.

3 Terms and definitions

For the purposes of this document, the following terms and definitions apply.

3.1

seamless round copper tube

hollow semi-finished product, circular in cross-section, made of copper, having a uniform wall thickness, which at all stages of production has a continuous periphery

3.2

soldering/brazing

joining process in which, during or after heating, molten filler metal is drawn into or retained in the space between closely adjacent surfaces of the parts to be joined by capillary attraction

3.2.1

soldering

soft soldering

joining process using filler metal with a liquidus temperature of 450 °C or less
[ISO 857-2:2005]

3.2.2

brazing

hard soldering

joining process using filler metal with a liquidus temperature above 450 °C

3.3

fusion welding

welding without application of outer force in which the facing surface(s) has (have) to be molten; usually, but not necessarily, molten filler metal is added

3.4

brazing

method of welding by using a filler metal that liquefies above 450 °C and below the solid state of the base metals. Unlike brazing, in braze welding, the filler metal is not distributed in the joint by capillary action

3.5

mean diameter

arithmetical mean of the maximum and minimum outside diameters through the same cross-section of the tube

3.6

deviation from circular form

difference between the maximum and minimum outside diameters measured at any one cross-section of the tube

3.7

deviation from concentricity

half of the difference between the maximum and minimum wall thicknesses at the same cross-section of the tube

3.8

production batch

definite quantity of products of the same form, the same material condition and the same cross-sectional dimensions manufactured during the same production sequence under uniform conditions

3.9

permanently marked

marked in such a way that the marking will remain readable up to the end of the life of the installation, e.g. by stamping, etching or engraving

3.10**durably marked**

marked in such a way that the marking will remain readable up to the time of commissioning of the installation

EXAMPLE ink marking

4 Designations**4.1 Material****4.1.1 General**

The material is designated either by symbol or number (see 7.1).

4.1.2 Symbol

The material symbol designation is based on the designation system given in ISO 1190-1.

4.1.3 Number

The material number designation is in accordance with the system given in EN 1412.

4.2 Material condition

For the purposes of this East African Standard, the following designation, which is in accordance with the system given in EN 1173, applies for the material condition (see Table 1):

R... Material condition designated by the minimum value of tensile strength requirement for the product with mandatory tensile strength and elongation requirements.

4.3 Product

The product designation provides a standardized pattern of designation from which a rapid and unequivocal description of a product is conveyed in communication. It provides mutual comprehension at the international level with regard to products which meet the requirements of the relevant European Standard.

The product designation is no substitute for the full content of the standard. The product designation for products to this East African Standard shall consist of:

- denomination (Copper tube);
- number of this East African Standard,
- material condition designation (see Table 1);
- nominal cross-sectional dimensions in millimetres: outside diameter x wall thickness.

The derivation of a product designation is shown in the following example.

EXAMPLE Copper tube conforming to this East African Standard, material condition R220 (annealed), nominal outside diameter 12 mm, nominal wall thickness 1,0 mm, shall be designated as follows:

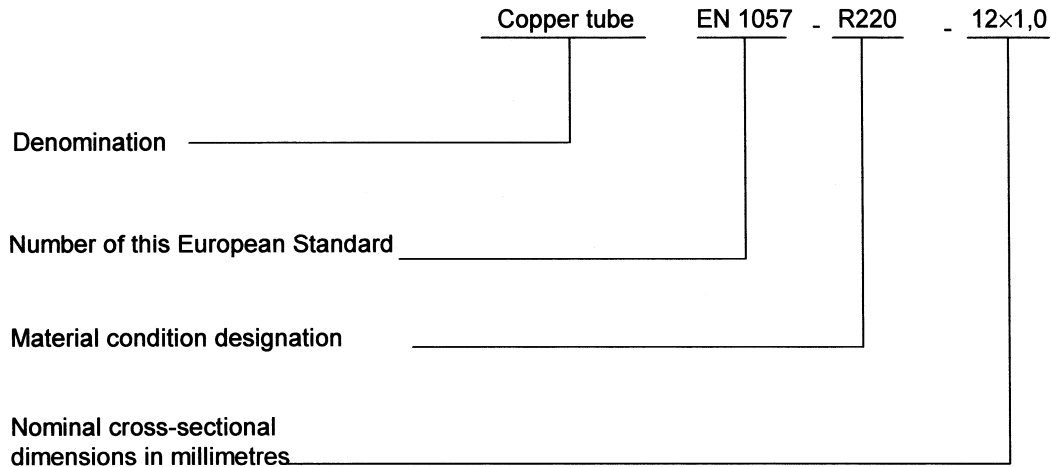

Draft for comments only — Not to be cited as EAS Standard

5 Ordering information

In order to facilitate the enquiry, order and confirmation of order procedures between the purchaser and the supplier, the purchaser shall state on his enquiry and order the following information:

- a) quantity of product required (in metres);
- b) denomination (Copper tube);
- c) number of this East African Standard;
- d) material condition designation (see 4.2 and Table 1);
- e) nominal cross-sectional dimensions: outside diameter × wall thickness (see Table 3 and Annex A);
- f) nominal length (see 12.2);
- g) form of delivery (see 12.2);

In addition, the purchaser shall also state on the enquiry and order any of the following, if required:

- h) drift expanding test: other than the mandatory cases, by agreement between the purchaser and the supplier, (see 7.7);
- i) flanging test: by agreement between the purchaser and the supplier (see 10.8);
- j) hardness test: by agreement between the purchaser and the supplier (see 10.3);
- k) whether an inspection document is required, and if so, which type (see Clause 11).

NOTE It is recommended that the product designation as described in 4.3, is used for items b) to e).

EXAMPLE Ordering details for 500 m copper tube conforming to EN 1057, in material condition R220 (annealed), nominal outside diameter 12 mm, nominal wall thickness 1,0 mm, in 50 m coils:

6 Material characteristics

6.1 Safety in case of fire — Reaction to fire

Copper tubes according to this Standard, i.e. without plastics covering, do not require to be tested for reaction to fire.

6.2 Properties at high temperature

The mechanical properties of copper at temperatures encountered in heating networks are not reduced significantly; for example, from ambient temperature up to 120 °C, it is not necessary to include the maximum admissible stress in pressure calculations.

6.3 Weldability

The suitability for welding is characteristic of the copper grade used for products in accordance with this European Standard, which is assured by control of the material composition.

NOTE Cu-DHP copper can be readily welded to produce a strong, homogeneous structure. Nevertheless, the advice of the manufacturer and welding professionals should be sought in order to ensure the correct selection of welding process, design and workmanship, taking into account thermal conductivity and coefficient of thermal expansion, to achieve the highest quality results.

7 Requirements

7.1 Composition

The composition shall conform to the following requirements:

Cu + Ag: min. 99.90 %;

0.015 % ≤ P ≤ 0.040%.

This copper grade is designated either Cu-DHP or CW024A.

7.2 Mechanical properties

The tensile strength and elongation shall conform to the requirements given in Table 1. The test shall be carried out in accordance with 10.2.

Table 1 — Mechanical properties

Material condition		Nominal outside diameter <i>d</i> mm		Tensile strength <i>R_m</i> MPa	Elongation A %	Hardness (indicative) HV 5
designation in accordance with EN 1173	common term	min.	max.	min.	min.	
R220	annealed	6	54	220	40	(40 to 70)
R250 a	half hard a	6	66.7	250	30 a	(75 to 100)
		6	159		20 a	
R290	hard	6	267	290	3	(min. 100)
NOTE 1 Hardness figures in parentheses are not requirements of this European Standard but are given for guidance purposes only.						
NOTE 2 1 MPa is equivalent to 1 N/mm ² .						
NOTE 3 Brittle fracture prevention: Copper, having a face-centred cubic crystal structure, does not suffer a transition from ductile to brittle failure like some other materials.						
^a See Table 2 for relationship between tube dimensions and elongation for R250 (half hard) tubes.						

The size range for values of elongation of R250 (half hard) tube is dependent on the relationship between diameter and wall thickness as shown in Table 2.

Table 2 — Minimal elongation values for R250 (half hard) material condition tubes

Values in millimetres

Nominal outside diameter ^a <i>d</i>	Nominal wall thickness <i>e</i>												
	0,5	0,6	0,7	0,75	0,8	0,9	1,0	1,1	1,2	1,5	2,0	2,5	3,0
6													
8													
10													
12													
14													
15													
16													
18													
22													
28													
35													
40		A ≥ 30 %											
42													
54													
64													
66,7													
70													
76,1													
80													
88,9										A ≥ 20 %			
108													
133													
159													
219													
267													

^a For remaining non-metric dimensions in Annex A, the rounded nearest diameter applies.

Elongation ≥ 30 % when $d \leq 66.7$ mm; and either $e < 1$ mm or $\frac{d}{e^2} > 24$;

Elongation ≥ 20 % when $d > 66.7$ mm; or $e \geq 1$ mm and also $\frac{d}{e^2} \leq 24$.

where

d is the nominal outside diameter in millimetres;

e is the nominal wall thickness in millimetres.

7.3 Dimensions and tolerances

7.3.1 General

The geometrical properties of the tube are defined by outside diameter, wall thickness and length. The outside diameter and wall thickness shall conform to the requirements given in Table 3 (or Table A.1), Table 4 and Table 5.

In cases of dispute these dimensions shall be measured at a temperature of $(23 \pm 5) ^\circ\text{C}$.

7.3.2 Nominal dimensions

The standardized nominal outside diameters and nominal wall thicknesses are given in Table 3 (or Table A.1). The lengths recommended are indicated in Table 10.

NOTE 1 These standardized dimensions have been selected from those used on the European market at the time of establishment of the present European Standard.

NOTE 2 A limited number of other dimensions have been listed in Annex A for reconsideration at a future revision of this European Standard.

NOTE 3 CEN/TC 133 has defined the recommended R marked dimensions as a step towards rationalization aiming for not more than three wall thickness for each diameter, and a restricted number of diameters.

NOTE 4 For reference purposes, if DN designation of size for components of a piping system is required, it can be calculated for tubes to this European Standard by: Nominal outside diameter (d) — $2 \times$ nominal wall thickness (e). DN is a numerical designation of size, which is common to all components in a piping system. It is a convenient round number for reference purposes and is only loosely related to the manufacturing dimensions (see ISO 6708).

Table 3 — Standardized dimensions

Values in millimetres

Nominal outside diameter <i>d</i>	Nominal wall thickness <i>e</i>											
	0,5	0,6	0,7	0,8	0,9	1,0	1,1	1,2	1,5	2,0	2,5	3,0
6		R		R		R						
8		R		R		R						
10		R	R	R		R						
12		R	R	R		R						
14				R		R						
15			R	R		R						
16						R						
18				R		R						
22					R	R	R	R	R			
28					R	R		R	R			
35						R		R	R			
40						R						
42						R		R	R			
54						R		R	R	R		
64										R		
66,7								R		R		
76,1									R	R		
88,9										R		
108									R		R	
133									R			R
159										R		R
219												R
267												R

R Indicates the dimensions recommended for consideration in national codes of practice. See also Annex A.

7.3.3 Tolerances on outside diameter

The outside diameter shall conform to the tolerances given in Table 4.

Table 4 — Tolerances on outside diameter

Values in millimeters

Nominal outside over diameter d		applicable to mean diameter all material conditions	Tolerances on nominal diameter applicable to any diameter ^a	
over	up to and including		R290 (hard) material condition	R250 (half hard) material condition
6 ^b	18	±0.04	±0.04	±0.09
18	28	±0.05	±0.06	±0.10
28	54	±0.06	±0.07	±0.11
54	76.1	±0.07	±0.10	±0.15
76.1	88.9	±0.07	±0.15	±0.20
88.9	108	±0.07	±0.20	±0.30
108	159	±0.2	±0.7	±0.4
159	267	±0.6	± 1.5	—

NOTE 1 Tolerances for tubes in R220 (annealed) material condition are applicable only to mean diameter.

NOTE 2 In case of dispute, to improve the accuracy when determining the mean diameter, the tube may be re-rounded before measurement.

^a Including deviation from circular form

^b Including 6

7.3.4 Tolerances on wall thickness

The tolerances on wall thickness expressed in percentage of the nominal thickness as measured at any point shall conform to the requirements given in Table 5.

Table 5 — Tolerances on wall thickness

Nominal outside diameter d mm	Tolerances on Δ $e < 1$ mm %	rail thickness e ^a $e \geq 1$ mm %
<18	±10	± 13
>18	±10	± 15 ^b

NOTE Concentricity (uniformity of wall thickness) is controlled by tolerance on wall thickness.

^a Including deviation from concentricity

^b ± 10 % for R250 (half hard) tubes of 35 mm, 42 mm and 54 mm diameters with a wall thickness of 1.2 mm

7.3.5 Tolerances on length

The lengths shall be equal to or greater than those ordered.

7.4 Freedom from defects

The tubes shall be free from defects that could be detrimental to their use. Each tube shall be subjected to one of the freedom from defects tests described in 10.9.

7.5 Surface quality

The outer and inner surfaces of the tubes shall be clean and smooth.

The inner surface shall neither contain any detrimental film nor present a carbon level high enough to allow the formation of such a film during installation. When tested in accordance with 10.4 and 10.5 as appropriate the tube shall conform to the appropriate requirements given in Table 6. The results of the tests shall be documented and presented to the purchaser, or his representative, upon request using the quantitative method in accordance with 10.4.

NOTE For routine quality control, it is at the discretion of the manufacturer to choose between quantitative analysis of carbon content or the carbon film test.

Table 6 — Quantitative and qualitative specification for carbon residues

Nominal outside diameter <i>d</i> mm	Material condition	Quantitative method — Total carbon ^a max. mg/dm ²	Qualitative method — Carbon film test
from 10 up to and including 54	R220 (annealed)	0.20	yes
	R250 (half hard)	0.20	yes
	R290 (hard)	0.20	yes
over 54	R250 (half hard)	0.20	yes
	R290 (hard)	1.0	no
NOTE To establish the inspection and control documents, only the quantitative method shall be used (see EN 723).			
^a Definition according to EN 723.			

7.6 Bending

No tear shall be visible to the unaided eye, corrected for normal vision, if necessary, when tubes of the sizes and material condition given in Table 7 are tested in accordance with 10.6. Strain bending (Lüders lines) shall be accepted.

7.7 Drift expanding

No crack, break or tearing of the metal shall be visible to the unaided eye, corrected for normal vision, if necessary, when tubes of the sizes and material conditions given in Table 7 (and agreed between the purchaser and the supplier, where necessary) are tested in accordance with 10.7.

7.8 Flanging

No crack on the tube edge shall be visible to the unaided eye, corrected for normal vision, if necessary, when tubes of the sizes and material condition given in Table 7 (and agreed between the purchaser and the supplier, where necessary) are tested in accordance with 10.8.

Table 7 — Testing of bending, drift expanding and flanging

Nominal outside diameter <i>d</i> mm		Material condition	bending ^a	rechnological tests drift expanding	flanging
over 6 ^b	up to and including 18	R220 (annealed)	—	M	A
		R250 (half hard)	—	M	—
		R290 (hard)	M	—	—
18	54	R220 (annealed)	—	A	A
		R250 (half hard)	—	A	—
		R290 (hard)	—	—	—
54	267	R220 (annealed)	—	—	—
		R250 (half hard)	—	—	—
		R290 (hard)	—	—	—
M — Mandatory					
A — To be agreed upon by the purchaser and the supplier					
^a For nominal wall thickness not less than 1 mm.					
^b Including 6.					

8 Evaluation of conformity

8.1 General

The conformity of copper tube to the requirements of this standard and with the stated values shall be demonstrated by:

- initial type testing;
- factory production control by the manufacturer, including product assessment.

8.2 Type testing

8.2.1 Initial type testing

An initial type test is the complete set of tests or other procedures, determining the performance of samples of products representative of the product type.

Initial type testing shall be performed to show conformity with this Standard.

Tests previously performed in accordance with the provisions of this Standard (same product, same characteristic(s), test method, sampling procedure, system of attestation of conformity etc.) may be taken into account. In addition, initial type testing shall be performed at the beginning of a new method of production (where this may affect the stated properties).

All requirements in Clause 7 shall be subject to initial type testing. The material characteristics in Clause 6, which may be assessed by control of the material, do not need testing because:

- reaction to fire;
- properties at high temperature — mechanical properties are not reduced significantly at temperatures concerned;
- weldability — copper grade Cu-DHP can be readily welded.

8.2.2 Sampling, testing and conformity criteria

8.2.2.1 Sampling

Initial type testing shall be performed on representative samples of the copper tube production to be placed on the market.

8.2.2.2 Testing and conformity criteria

Copper tubes shall be tested for conformity to the requirements listed in Clause 7 in accordance with the relevant methods given in Clause 10.

The results of all type tests shall be recorded and held by the manufacturer for at least 5 years after the end of production of the product for which the ITT is representative.

8.3 Factory production control (FPC)

8.3.1 General

The manufacturer shall establish, document and maintain an FPC system to ensure that the products placed on the market conform to the declared performance characteristics. The FPC system shall consist of written procedures (works' manual), regular inspections and tests and/or assessments and the use of the results to control raw and other incoming materials, equipment, the production process and the product.

All elements, requirements and provisions of FPC adopted by the manufacturer shall be documented in a systematic manner in the form of written policies and procedures. This production control system documentation shall ensure a common understanding of conformity evaluation and enable the achievement of the required component characteristics and the effective operation of the production control system to be checked.

Factory production control therefore brings together operational techniques and all measures allowing maintenance and control of the conformity of the product with its technical specifications. Its implementation may be achieved by controls and tests on measuring equipment, raw materials, processes, machines and manufacturing equipment and finished products, including material properties of the products, and by making use of the results thus obtained.

An FPC system conforming with the requirements of ISO 9001, and made specific to the requirements of this standard, is considered to satisfy the above requirements.

8.3.2 General FPC requirements

The FPC system shall fulfil the requirements as described in the following clauses of ISO 9001, where applicable:

- 4.2 except 4.2.1 a);
- 5.1 e), 5.5.1, 5.5.2;
- Clause 6;
- 7.1 except 7.1 a), 7.2.3 c), 7.4, 7.5, 7.6;
- 8.2.3, 8.2.4, 8.3, 8.5.2.

NOTE The FPC system may be part of a Quality Management system, e.g. in accordance with ISO 9001.

The manufacturer shall establish procedures to ensure that the production tolerances allow for the copper tube performances to be in conformity with the declared values derived from initial type testing.

The characteristics and the means of verification are given in Clauses 7 and 10 and the minimum frequency of testing is given in Table 8.

The manufacturer shall record the results of the tests specified above. These records shall at least include the following information:

- identification of the copper tube tested;
- date of testing;
- test results.

8.3.3 Manufacturer-specific FPC system requirements

8.3.3.1 Personnel

The responsibility, authority and the relationship between personnel that manages, performs or verifies work affecting product conformity, shall be defined. This applies in particular to personnel that needs to initiate actions preventing product non-conformities from occurring, actions in case of non-conformities and to identify and register product conformity problems.

8.3.3.2 Equipment

All weighing, measuring and testing equipment necessary to achieve, or produce evidence of, conformity shall be calibrated or verified and regularly inspected according to documented procedures, frequencies and criteria. Control of monitoring and measuring devices shall conform to the appropriate clause of ISO 9001.

All equipment used in the manufacturing process shall be regularly inspected and maintained to ensure use, wear or failure does not cause inconsistency in the manufacturing process.

8.3.3.3 Raw materials

The specifications of all incoming raw materials shall be documented, as shall be the inspection scheme for ensuring their conformity. The verification of conformity of the raw material with the specification shall be in accordance with ISO 9001, 7.4.3.

8.3.3.4 In-process control

The manufacturer shall plan and carry out production under controlled conditions. Compliance with ISO 9001, 7.5.1 and 7.5.2 shall be deemed to satisfy the requirements of this clause.

8.3.3.5 Traceability and marking

Individual copper tubes, batches or packages shall be identifiable and traceable with regard to their production origin. The manufacturer shall have written procedures ensuring that processes related to affixing traceability codes and/or markings (see Clause 12) are inspected regularly. Compliance with EN ISO 9001:2000, 7.5.3 shall be deemed to satisfy the requirements of this clause.

8.3.3.6 Non-conforming products

The manufacturer shall have written procedures which specify how non-conforming products shall be dealt with. Any such events shall be recorded as they occur and these records shall be kept for the period defined in the manufacturer's written procedures. Compliance with ISO 9001, 8.3 shall be deemed to satisfy the requirements of this clause.

8.3.3.7 Corrective action

The manufacturer shall have documented procedures that instigate action to eliminate the cause of nonconformities in order to prevent recurrence. Compliance with ISO 9001, 8.5.2 shall be deemed to satisfy the requirements of this clause.

8.3.3.8 Handling, storage, packaging

The manufacturer shall have written procedures providing methods of product handling and shall provide suitable storage areas preventing damage or deterioration.

9 Sampling

For the purpose of quality assurance during production, the number of sampling units to be taken at random shall be in accordance with Table 8.

Table 8 — Sampling rate

Tube mass per meter kg/m	Quantity for one sampling unit at predicted monthly meterage ^a	
	< 100 000 m kg	≥ 100 000 m kg
≤ 0.25	1 500	3 000
> 0.25	2 500	5 000

^a At least one sampling unit shall be taken per production batch.

These sampling rates shall apply when testing for dimensional controls; controls of other mandatory properties shall be carried out on each second sampling unit.

Results may be used from analyses carried out at an earlier stage of manufacturing the product, e.g. at the casting or billets inward stage, if product identity is maintained and if the quality management system of the manufacturer conforms to the relevant requirements of ISO 9001.

10 Test methods

10.1 Analysis

For composition, analysis shall be carried out on the test samples obtained in accordance with Clause 9. The analytical methods used shall be chemical or spectrographic in accordance with appropriate European or International Standards. In cases of dispute the reference method shall be by chemical analysis according to ISO 1553 and ISO 4741.

10.2 Tensile test

The tensile test shall be carried out in accordance with the method given in ISO 6892 on test pieces prepared from the samples obtained in accordance with Clause 9.

10.3 Hardness test

When required and after agreement between the purchaser and the supplier, the Vickers hardness test shall be carried out in accordance with ISO 6507-1.

10.4 Carbon content test

The determination of carbon content shall be carried out on the samples obtained in accordance with Clause 9 using the reference method described in EN 723.

NOTE For factory production control, it is at the discretion of the manufacturer to choose between quantitative analysis of carbon content and the carbon film test.

10.5 Carbon film test

The detection and assessment of carbon film shall be carried out on the samples obtained in accordance with Clause 9 using the method described in Annex B.

10.6 Bending test

When required, the bending test shall be carried out under current operating conditions using appropriate bending machines without internal mandrel in accordance with ISO 8491. The test piece shall be bent to an angle of 90° and to the appropriate minimum radius of curvature given in Table 9.

NOTE The result of bending on site may be different from the result of the bending test carried out under laboratory conditions due to tooling variations.

Table 9 — Minimum radius of curvature

Dimensions in millimeters

Nominal outside diameter d	Minimum radius of curvature	
	internal radius	neutral axis radius
6	27	30
8	31	35
10	35	40
12	39	45
14	43	50
15	48	55
16	52	60
18	61	70

10.7 Drift-expanding test

When required, the drift-expanding test shall be carried out in accordance with ISO 8493. The outside diameter of the tube end shall be expanded by 30 % using a conical mandrel having an angle of 45°.

10.8 Flanging test

When required, the flanging test shall be carried out in accordance with ISO 8494. After testing, the outside diameter of the flange shall be at least 30 % greater than the nominal tube diameter when the tube was formed on a flanging tool with a corner radius of approximately 1 mm.

10.9 Freedom from defects tests

Each tube shall be subjected to one of the following tests:

- eddy current test for detection of local defects, in accordance with EN 1971 and the requirements in C.1;
- hydrostatic test in accordance with the method in C.2;
- pneumatic test in accordance with the method in C.3.

Except for initial type testing, when only the eddy current test shall be used, the choice of the method, selected from the above, is at the discretion of the manufacturer.

10.10 Retests

In the event that the sample fails to meet the test requirements the batch represented by the sample or, in the case of continuous production all tubes manufactured since the previous check, shall be placed in a bond.

Further samples shall be taken from the bonded tubes at a sampling rate four times more frequent than specified in Clause 9. If any of the retest samples fail to meet the specification requirements the tubes represented by the samples shall be deemed not to meet the requirements of this Standard and shall be rejected. If all the retest samples meet the requirements, the tubes represented by the samples shall be deemed to meet the requirements of this Standard.

11 Inspection documentation

When requested by the purchaser [see 5 k)] and agreed with the supplier, the supplier shall issue for the products S; the appropriate inspection document in accordance with EN 10204.

12 Marking and form of delivery

12.1 Marking

Tubes from 10 mm up to and including 54 mm diameter shall be permanently marked at repeated distances along their length of not greater than 600 mm, with at least the following:

Permanent marking:

- number of this Standard;
- manufacturer's identification mark;
- date of production: year and quarter (I to IV) or year and month (1 to 12). The marking shall not be detrimental to the use of the tube. Durable or permanent marking:
- nominal cross-sectional dimensions: outside diameter x wall thickness;
- identification for R250 (half hard) material condition by the following symbol: I-I.

Tubes from 6 mm but less than 10 mm, or greater than 54 mm diameter shall be at least similarly marked legibly at both ends.

The marking shall do nothing to either obscure or cause confusion with any regulatory marking, e.g. CE marking.

12.2 Form of delivery

The recommended form of delivery of tubes is given in Table 10.

Table 10 — Recommended form of delivery

Form of delivery	Nominal outside diameter d mm		Nominal length m	Material condition
	from	up to and including		
Coils	6	28	25; 50	R220 (annealed)
Straight lengths	6	267	3; 5	R250 (half hard)
				R290 (hard)

Draft for comments only — Not to be cited as East African Standard

Annex A
(normative)

Standardized dimensions for reconsideration at a future revision

Table A.1 — Standardized dimensions for reconsideration at a future revision

Nominal outside diameter <i>d</i>	<i>Dimensions in millimetres</i>												
	0.5	0.6	0.7	0.75	0.8	0.9	1.0	1.1	1.2	1.5	2.0	2.5	3.0
6	X												
8	X												
10	X												
12	X												
14,68 (14,7 ^a)			X										
15	X			X					X	X			
16					X				X				
18		X		X					X	X			
21,03(21 a)		X				X				X			
22		X											
27,38 (27,4 ^a)						X							
28		X								X			
34, 13 (34 a)								X					
35											X		
40,48 (40.5 ^a)								X					
42											X		
53,59 (53.6 ^a)									X				
64										X		X	
66.7							X			X		X	
70											X	X	
76.1									X			X	
80							X				X		
88.9												X	X
108									X		X		X
133											X		
159										X			

^a Designated outside diameter for the Irish market

Annex B
(normative)

Carbon film test

B.1 Preparation of the test piece

The sample of tube to be tested shall be cleaned on its outside surface either abrasively by filing or turning in order to remove all traces of the original surface finish or chemically by sealing one end with an acid resistant plug and then immersing in concentrated nitric acid to pickle the outside surface and then rinsing with de-ionized water and drying.

A sample, at least 25 mm long, shall be then cut from the cleaned section, using a clean saw blade and cut in half longitudinally to make two test pieces. One test piece shall be degreased by dipping in acetone.

For tube dimensions exceeding 22 mm x 1 mm a sample of comparable surface area shall be taken, the preparation of which shall correspond to the procedure described above.

B.2 Procedure

The degreased test piece shall be placed, with its internal surface upwards, in a small, flat-bottomed white porcelain or glass dish and covered with 25 % (mass fraction) nitric acid at ambient temperature.

The acid causes loosening of surface deposits which will float to the surface. When the acid turns blue in colour the test piece shall be removed and rinsed with de-ionized water to wash back into the acid any particles adhering to the test piece.

B.3 Detection and assessment of films

The reaction of the test piece in the acid shall be observed with a microscope of X10 magnification.

The initial observation will assess whether a material released by the acid is in the form of a film or particulate. If nothing is detected, or particles are found, the test is passed.

If clearly visible films are seen floating to the surface these may be of carbon or oxide.

To distinguish between carbon and oxide, the porcelain or glass dish shall be gently heated and the acid allowed to boil for about 5 min to dissolve any oxide films.

If on re-examination the films have been eliminated or only particles remain, the test is passed. If there is no reduction in the film element, then it is carbon and the test is failed.

Annex C (normative)

Freedom from defects tests

C.1 Eddy current test

Maximum drill diameters for the reference standard tube, which is defined in EN 1971, are given in Table C.1.

Table C.1 — Maximum drill diameters for the reference standard tube

Dimensions in millimetres

Nominal outside diameter <i>d</i>		Drill diameter
over	up to and including	max.
6 ^a	28	1.2
28	267	2.0
^a Including 6.		

Signals produced by reference standard tubes set the sorting limits for acceptance or rejection. Tubes containing defects which produce signals equal to or greater than the sorting limit shall be rejected.

C.2 Hydrostatic test

The tube under test shall be connected to a source of pressurized water. Water pressure as specified in Table C.2 shall be maintained in the tube for a minimum period of 10 s without evidence of leaking. If one or more leaks are observed, the tube shall be rejected. If no leak is observed, the tube shall be accepted.

Table C.2 — Hydraulic pressure test

Nominal outside diameter <i>d</i> mm		Hydraulic pressure bar min.
over	up to and including	
6 ^a	54	35
54	108	25
108	159	15
159	267	10
NOTE 1 bar is equivalent to 0.1 MPa.		
^a Including 6.		

C.3 Pneumatic test

The tube under test shall be connected to a source of pressurized air. Air pressure at 4 bar (0.4 MPa) shall be maintained in the tube.

The tube shall be completely immersed in water for a minimum period of 10 s and inspected for the issue of bubbles from the tube. Should any bubbles be observed then the tube shall be rejected. If no bubbles are observed then the tube shall be accepted.

Bibliography

In the preparation of this European Standard, use was made of a number of documents for reference purposes. These informative references are cited at the appropriate places in the text and the publications are listed hereafter.

- [1] EN 1173, *Copper and copper alloys — Material condition or temper designation*
- [2] EN 1412, *Copper and copper alloys — European numbering system*
- [3] ISO 6708, *Pipework components — Definition and selection of DN (nominal size)*
- [4] ISO 857-1, *Welding and allied processes — Vocabulary — Part 1: Metal welding processes*
- [5] ISO 857-2:2005, *Welding and allied processes — Vocabulary — Part 2: Soldering and brazing processes and related terms*
- [6] ISO 1190-1, *Copper and copper alloys— Code of designation — Part 1: Designation of materials*

Draft for comments only — Not to be cited as East African Standard

Draft for comments only — Not to be cited as East African Standard