



CD/K/012:2009
ICS 23.040.01

EAST AFRICAN STANDARD

**Classification and information on design of plastics piping systems
used for renovation**

EAST AFRICAN COMMUNITY

Foreword

Development of the East African Standards has been necessitated by the need for harmonizing requirements governing quality of products and services in East Africa. It is envisaged that through harmonized standardization, trade barriers which are encountered when goods and services are exchanged within the Community will be removed.

In order to meet the above objectives, the EAC Partner States have enacted an East African Standardization, Quality Assurance, Metrology and Test Act, 2006 (EAC SQMT Act, 2006) to make provisions for ensuring standardization, quality assurance, metrology and testing of products produced or originating in a third country and traded in the Community in order to facilitate industrial development and trade as well as helping to protect the health and safety of society and the environment in the Community.

East African Standards are formulated in accordance with the procedures established by the East African Standards Committee. The East African Standards Committee is established under the provisions of Article 4 of the EAC SQMT Act, 2006. The Committee is composed of representatives of the National Standards Bodies in Partner States, together with the representatives from the private sectors and consumer organizations. Draft East African Standards are circulated to stakeholders through the National Standards Bodies in the Partner States. The comments received are discussed and incorporated before finalization of standards, in accordance with the procedures of the Community.

Article 15(1) of the EAC SQMT Act, 2006 provides that "Within six months of the declaration of an East African Standard, the Partner States shall adopt, without deviation from the approved text of the standard, the East African Standard as a national standard and withdraw any existing national standard with similar scope and purpose".

East African Standards are subject to review, to keep pace with technological advances. Users of the East African Standards are therefore expected to ensure that they always have the latest versions of the standards they are implementing.

© East African Community 2010 — All rights reserved*

East African Community

P O Box 1096

Arusha

Tanzania

Tel: 255 27 2504253/8

Fax: 255-27-2504481/2504255

E-Mail: eac@eachq.org

Web: www.each.int

* © 2010 EAC — All rights of exploitation in any form and by any means reserved worldwide for EAC Partner States' NSBs.

Introduction

In the preparation of this East African Standard, the following source was consulted extensively:

ISO 11295:2010, *Classification and information on design of plastics piping systems used for renovation*

Assistance derived from this source and others inadvertently not mentioned is hereby acknowledged.

Draft for comments only — Not to be cited as East African Standard

**Classification and information on design
of plastics piping systems used for
renovation**

*Classification et informations relatives à la conception des systèmes
de canalisations en plastique destinés à la rénovation*

Draft for comments only — Not to be cited as East African Standard



PDF disclaimer

This PDF file may contain embedded typefaces. In accordance with Adobe's licensing policy, this file may be printed or viewed but shall not be edited unless the typefaces which are embedded are licensed to and installed on the computer performing the editing. In downloading this file, parties accept therein the responsibility of not infringing Adobe's licensing policy. The ISO Central Secretariat accepts no liability in this area.

Adobe is a trademark of Adobe Systems Incorporated.

Details of the software products used to create this PDF file can be found in the General Info relative to the file; the PDF-creation parameters were optimized for printing. Every care has been taken to ensure that the file is suitable for use by ISO member bodies. In the unlikely event that a problem relating to it is found, please inform the Central Secretariat at the address given below.



COPYRIGHT PROTECTED DOCUMENT

© ISO 2010

All rights reserved. Unless otherwise specified, no part of this publication may be reproduced or utilized in any form or by any means, electronic or mechanical, including photocopying and microfilm, without permission in writing from either ISO at the address below or ISO's member body in the country of the requester.

ISO copyright office
Case postale 56 • CH-1211 Geneva 20
Tel. + 41 22 749 01 11
Fax + 41 22 749 09 47
E-mail copyright@iso.org
Web www.iso.org

Published in Switzerland

Contents

Page

Foreword	iv
Introduction.....	v
1 Scope	1
2 Normative references	1
3 Terms and definitions	1
4 Abbreviated terms	3
5 Classification of renovation techniques	3
5.1 General	3
5.2 Lining with continuous pipes	4
5.3 Lining with close-fit pipes	6
5.4 Lining with cured-in-place pipes	8
5.5 Lining with discrete pipes	10
5.6 Lining with adhesive-backed hoses	12
5.7 Lining with spirally-wound pipes.....	13
6 Information on design	14
6.1 General	14
6.2 Condition assessment	15
6.3 Lining system functions	16
6.4 Performance criteria.....	17
6.5 Other factors affecting lining system selection	20
Annex A (informative) Process-related aspects	22
Bibliography.....	28

Foreword

ISO (the International Organization for Standardization) is a worldwide federation of national standards bodies (ISO member bodies). The work of preparing International Standards is normally carried out through ISO technical committees. Each member body interested in a subject for which a technical committee has been established has the right to be represented on that committee. International organizations, governmental and non-governmental, in liaison with ISO, also take part in the work. ISO collaborates closely with the International Electrotechnical Commission (IEC) on all matters of electrotechnical standardization.

International Standards are drafted in accordance with the rules given in the ISO/IEC Directives, Part 2.

The main task of technical committees is to prepare International Standards. Draft International Standards adopted by the technical committees are circulated to the member bodies for voting. Publication as an International Standard requires approval by at least 75 % of the member bodies casting a vote.

Attention is drawn to the possibility that some of the elements of this document may be the subject of patent rights. ISO shall not be held responsible for identifying any or all such patent rights.

ISO 11295 was prepared by Technical Committee ISO/TC 138, *Plastics pipes, fittings and valves for the transport of fluids*.

This first edition of ISO 11295 cancels and replaces ISO/TR 11295:1992.

Introduction

This International Standard classifies the techniques used for the renovation of existing pipelines and gives information on the design of plastics piping systems used for such renovation.

Over the past 25 years, the rehabilitation of pipeline systems has become increasingly important.

Pipeline systems are continuously required to satisfy physical, chemical, biochemical and biological demands. These demands depend on planning, material, construction, type and period of use.

When pipeline systems become operational, proper system management has to be put in place. In addition to inspection and cleaning, rehabilitation of the pipeline can be required. Rehabilitation is carried out when there is need for restoration or upgrading of the pipeline system in terms of its performance. Rehabilitation can consist of repair, renovation or replacement.

To coincide with the publication of ISO product standards for various families of renovation techniques in three different application areas, the need to upgrade ISO/TR 11295 to a full International Standard was recognized, and, at the same time, focus on renovation.

Draft for comments only — Not to be cited as East African Standard

Draft for comments only — Not to be cited as East African Standard

Classification and information on design of plastics piping systems used for renovation

1 Scope

This International Standard defines and describes families of techniques for the renovation of non-pressure and pressure pipelines through the use of plastics pipes, fittings and ancillary components. For each technique family, it identifies areas of application from the range covered by existing renovation product standards, which include underground drainage and sewerage, and underground water and gas supply networks.

This International Standard provides information on the principles of, but not the detailed methodologies for, the design of plastics piping systems applied as linings to existing pipelines, covering:

- existing pipeline and site conditions;
- lining system functions;
- structural performance;
- hydraulic performance;
- other factors affecting lining system selection.

It does not cover the calculation methods used to determine, for each viable technique, the required amount of lining material needed to secure the desired performance of the renovated pipeline.

2 Normative references

The following referenced documents are indispensable for the application of this document. For dated references, only the edition cited applies. For undated references, the latest edition of the referenced document (including any amendments) applies.

ISO 1043-1, *Plastics — Symbols and abbreviated terms — Part 1: Basic polymers and their special characteristics*

3 Terms and definitions

For the purposes of this document, the terms and definitions given in ISO 1043-1 and the following apply.

NOTE For ease of reference, see Clause 5 for definitions of the following individual technique families reproduced from other International Standards:

- lining with continuous pipes;
- lining with close-fit pipes;
- lining with cured-in-place pipes;

- lining with discrete pipes;
- lining with adhesive-backed hoses;
- lining with spirally-wound pipes.

3.1

lining pipe

pipe inserted for renovation purposes

3.2

liner

lining pipe after installation

3.3

lining system

lining pipe and all relevant fittings inserted into an existing pipeline for the purposes of renovation

3.4

maintenance

keeping an existing pipeline system operational without the installation of additional fabric

3.5

rehabilitation

all measures for restoring or upgrading the performance of an existing pipeline system

3.6

renovation

work incorporating all or part of the original fabric of the pipeline, by means of which its current performance is improved

3.7

repair

rectification of local damage

3.8

replacement

rehabilitation of an existing pipeline system by the installation of a new pipeline system, without incorporating the original fabric

3.9

technique family

grouping of renovation techniques which are considered to have common characteristics for standardization purposes

3.10

independent pressure pipe liner

liner capable on its own of resisting without failure all applicable internal loads throughout its design life

3.11

interactive pressure pipe liner

liner which relies on the existing pipeline for some measure of radial support in order to resist without failure all applicable internal loads throughout its design life

3.12

fully structural rehabilitation

renovation using an independent pressure pipe liner

3.13**semi-structural rehabilitation**

renovation using an interactive pressure pipe liner which is capable of long-term hole and gap spanning at operational pressure

4 Abbreviated terms

EP	Epoxy resin
GRP	Glass-reinforced thermosetting plastics
PA	Polyamide
PAN	Polyacrylonitrile
PE	Polyethylene
PE-X	Cross-linked polyethylene
PEN	Poly(ethylene naphthate)
PET	Poly(ethylene terephthalate)
PP	Polypropylene
PRP	Polyester-reinforced PE
PUR	Polyurethane
PVC-U	Unplasticized poly(vinyl chloride)
UP	Unsaturated polyester resin
VE	Vinyl ester resin

5 Classification of renovation techniques**5.1 General**

This clause establishes a classification of the techniques used for the renovation of continuous lengths of existing pipeline usually between two or more access points.

Renovation techniques within the scope of this International Standard are classified in Figure 1.

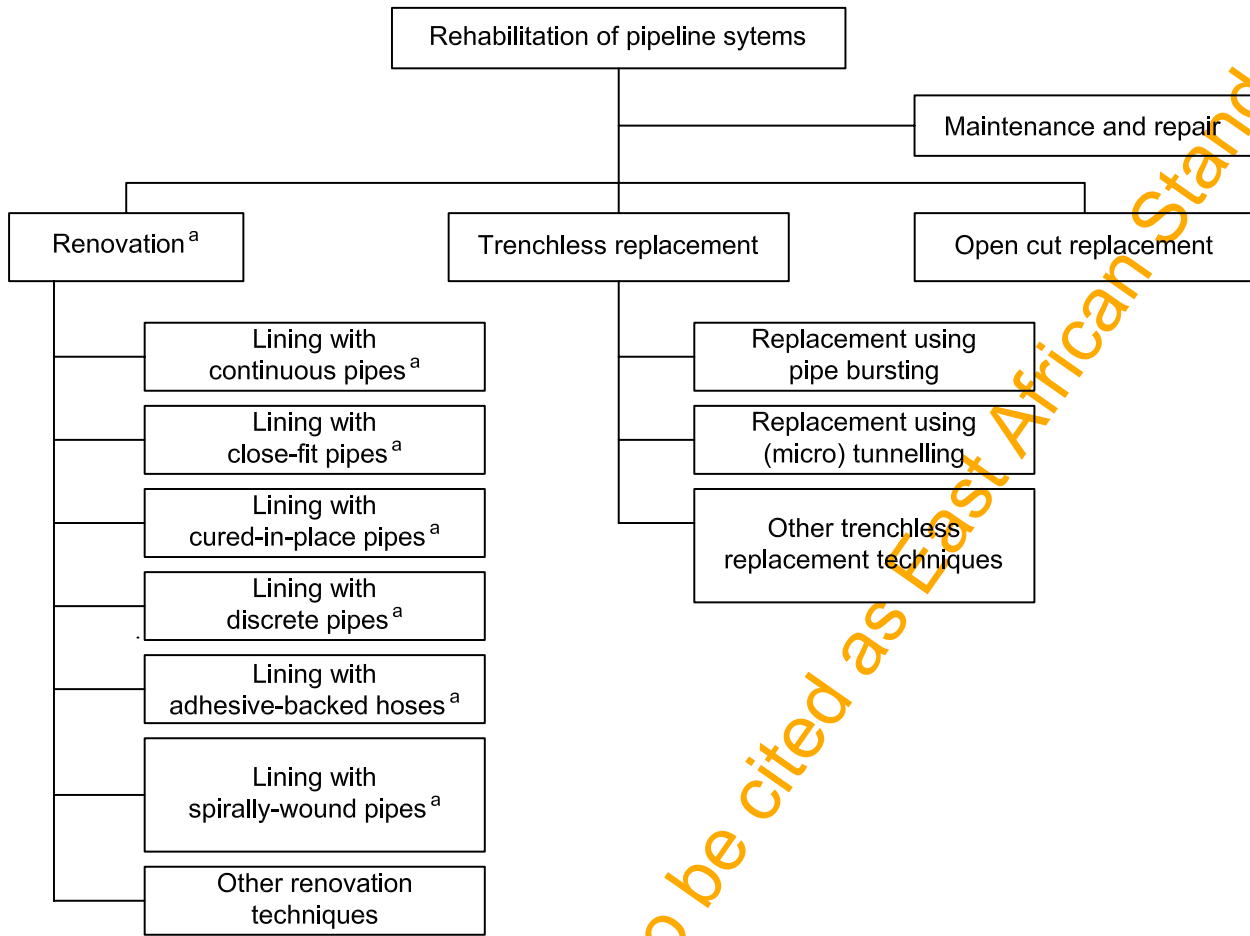

^a This International Standard is applicable.

Figure 1 — Renovation technique families using plastics pipes defined in the overall context of rehabilitation of pipeline systems

In 5.2 to 5.7, the different renovation technique families are defined and associated materials and areas of application, which are the subject of existing or foreseen product standards, are identified. In addition, certain general characteristics of each renovation technique family are described.

NOTE 1 The pipe materials listed in 5.2 to 5.7 reflect the state-of-the-art in the technique families on the date of publication of this International Standard. Not all technique families/material-combinations are covered by a renovation product standard. The Bibliography gives relevant available standards.

NOTE 2 The application areas covered by existing renovation product standards include underground drainage and sewerage, and underground water and gas supply networks. This International Standard is not applicable to other possible areas of application of the technique families described.

5.2 Lining with continuous pipes

Lining with continuous pipes is defined as lining with pipes made continuous prior to insertion; the cross-section of the lining pipe remains unchanged (see Figure 2).

NOTE This is often referred to as sliplining.

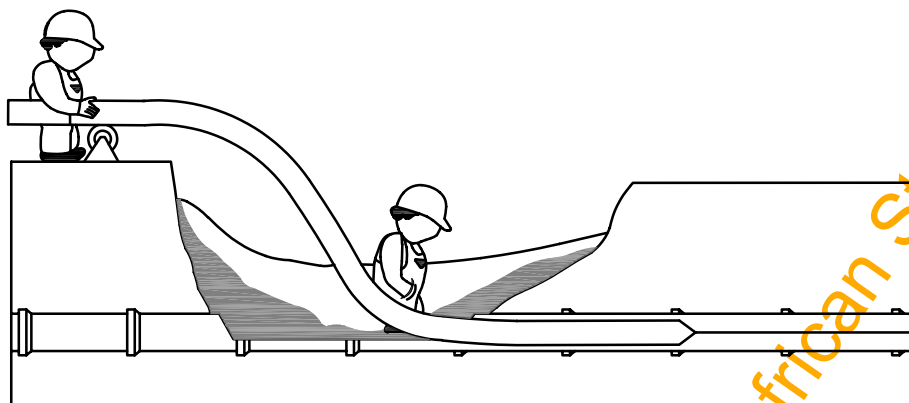

Figure 2 — Schematic representation of lining with continuous pipes

Relevant existing International Standard(s):	<ul style="list-style-type: none"> a) ISO 11296-1 and EN 13566-2; b) ISO 11298-1; c) ISO 11299-1.
Materials:	PE, PE-X and PP.
Applications:	Pressure pipes and non-pressure pipes (applicable to all areas).
Geometric capabilities:	<ul style="list-style-type: none"> a) typical minimum size: 100 mm; b) typical maximum size: 2 000 mm; c) typical maximum length: 300 m; d) capability of accommodating bends, depending on technique.
Performance:	<ul style="list-style-type: none"> a) reduction in hydraulic capacity significant; b) fully structural rehabilitation is possible.
Installation characteristics:	<ul style="list-style-type: none"> a) pipes manufactured or prior assembled into the continuous length required; b) insertion possible by pushing and/or pulling; c) surface working space <ul style="list-style-type: none"> — small diameters: can be supplied on coils, small space, and — larger diameters: supplied in straight lengths requiring greater storage and working space; d) access to the existing pipeline: generally requires local excavation; e) technique does not rely on adhesion to host pipe; f) flow diversion is typically required for installation and grouting; g) the annular space may be grouted, at least in non-pressure applications, to fix line and level and/or prevent subsequent movement; h) live insertion is possible (but drinking water applications excluded for hygiene reasons); i) reconnection of laterals/services: generally requires excavation.

5.3 Lining with close-fit pipes

Lining with close-fit pipes is defined as lining with a continuous pipe for which the cross-section is reduced to facilitate installation and reverted after installation to provide a close fit to the existing pipe (see Figure 3).

NOTE For the reduction in cross-section, the following are the two options:

- a) reduction in the pipe manufacturing plant: the pipe is usually supplied coiled on a reel from which it is directly inserted;
- b) reduction on site: the pipe is usually fed through the reduction equipment and simultaneously inserted in one continuous string.

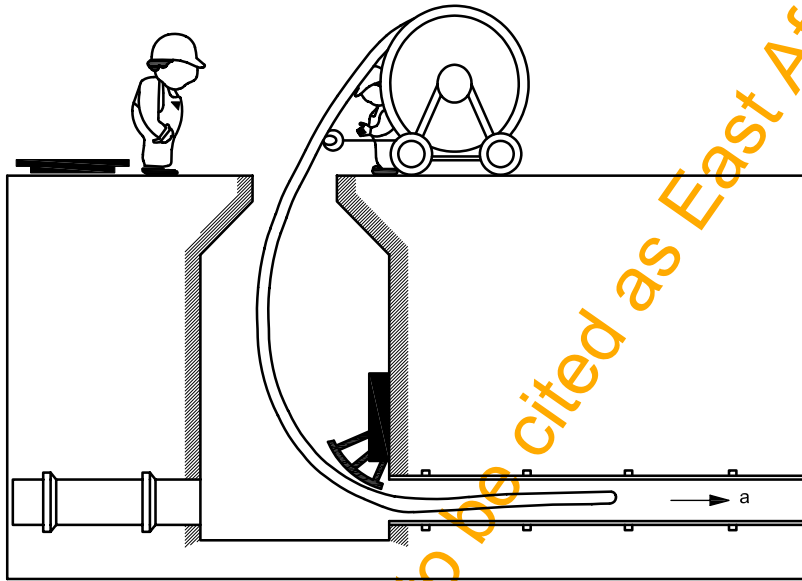

a) Installation of a pipe reduced in cross-section in the pipe manufacturing plant

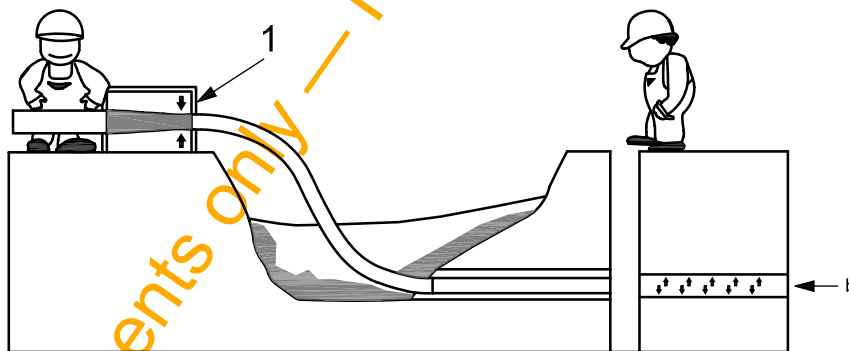

b) Installation of a pipe reduced in cross-section on site

Key

- 1 device for reducing cross-section
- a Direction of feed (by pulling) of lining pipe into the host pipe.
- b Pressure applied for reversion.

Figure 3 — Schematic representations of lining with close-fit pipes

Relevant existing International Standard(s):	<ul style="list-style-type: none"> a) ISO 11296-1 and ISO 11296-3; b) ISO 11298-1 and ISO 11298-3; c) ISO 11299-1 and ISO 11299-3.
Materials:	PE, PE-X, PP, PRP and PVC-U.
Applications:	Pressure pipes and non-pressure pipes (applicable to all areas).
Geometric capabilities:	<ul style="list-style-type: none"> a) shape <ul style="list-style-type: none"> — circular, and — non-circular shapes are possible; b) typical minimum size: 75 mm; c) typical maximum size <ul style="list-style-type: none"> — factory reduced: 500 mm, and — site reduced: 1 500 mm; d) typical maximum length: 500 m; e) capability of accommodating substantial bends, depending on technique.
Performance:	<ul style="list-style-type: none"> a) minimal reduction in capacity; increase in flow possible; b) fully structural rehabilitation possible.
Installation characteristics:	<ul style="list-style-type: none"> a) lining pipe first reduced in size by mechanical or thermo-mechanical means (in the manufacturing plant or on site), inserted and then reverted by relief of installation forces or application of heat and/or pressure; b) surface working space for <ul style="list-style-type: none"> — factory-reduced pipe: no particular constraint, and — site-reduced pipe: larger diameters supplied in straight lengths require greater storage and working space; c) access for <ul style="list-style-type: none"> — factory-reduced pipe: typically through existing access chambers, where applicable, and — site-reduced pipe: requires local excavation; d) technique does not rely on adhesion to host pipe; e) flow interruption/diversion typically required; f) no grouting required; g) reconnection of laterals/services for <ul style="list-style-type: none"> — gravity pipelines: possible from inside (re-opening and tight connection), and — pressure applications: generally requires excavation.

5.4 Lining with cured-in-place pipes

Lining with cured-in-place pipes is defined as lining with a flexible tube impregnated with a thermosetting resin, which produces a pipe after resin cure (see Figure 4).

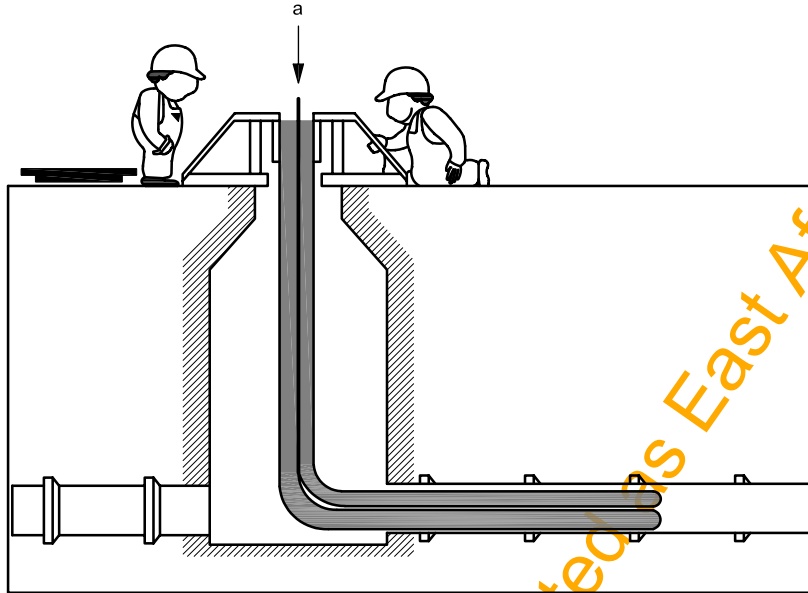

a) Installation by inversion

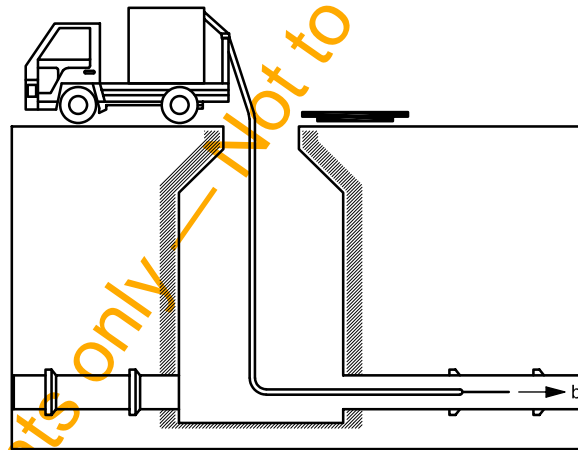

- a Pressure applied for inversion.
- b Pulling force.

b) Winched-in-place installation

Figure 4 — Schematic representation of lining with cured-in-place pipes

- Relevant existing International Standard(s):
- a) ISO 11296-1 and ISO 11296-4;
 - b) ISO 11298-1;
 - c) ISO 11299-1.
- Materials:
- A composite consisting of a reinforced or unreinforced fabric carrier material impregnated with thermosetting resin (UP, EP or VE), which can include optional internal and/or external membranes. For details, see the relevant standard.
- Applications:
- Pressure pipes and non-pressure pipes (drains and sewers, water).
- Geometric capabilities:
- a) non-circular shapes are possible;
 - b) typical minimum size: 125 mm;
 - c) typical maximum size: 2 800 mm;
 - d) typical maximum length: 100 m to 600 m (technique-dependent);
 - e) capability of accommodating substantial bends, depending on technique.
- Performance:
- a) minimal reduction in capacity; increase in flow possible;
 - b) fully structural rehabilitation possible.
- Installation characteristics:
- a) insertion of the impregnated tube, prior to curing, can be achieved by either
 - winching into place and then inflating,
 - inverting into position with fluid pressure only (water or air), or
 - winching one tube into place and then inflating with a second, inverted, tube;
 - b) the curing process can be initiated or accelerated by either
 - ambient temperature,
 - heat (hot water, steam or electrical heating elements), or
 - UV radiation;
 - c) surface working space generally minimal, increases for long lengths in largest sizes;
 - d) entry via existing manhole or small excavation possible;
 - e) structural effect does not rely on adhesion to host pipe;
 - f) flow interruption/diversion typically required;
 - g) grouting of annular space not necessary;
 - h) re-opening of laterals/services from inside is possible;
 - i) creation of a tight connection from inside is possible.

5.5 Lining with discrete pipes

Lining with discrete pipes is defined as lining with pipes shorter than the section to be renovated, which are jointed to form a continuous pipe only during insertion (see Figure 5).

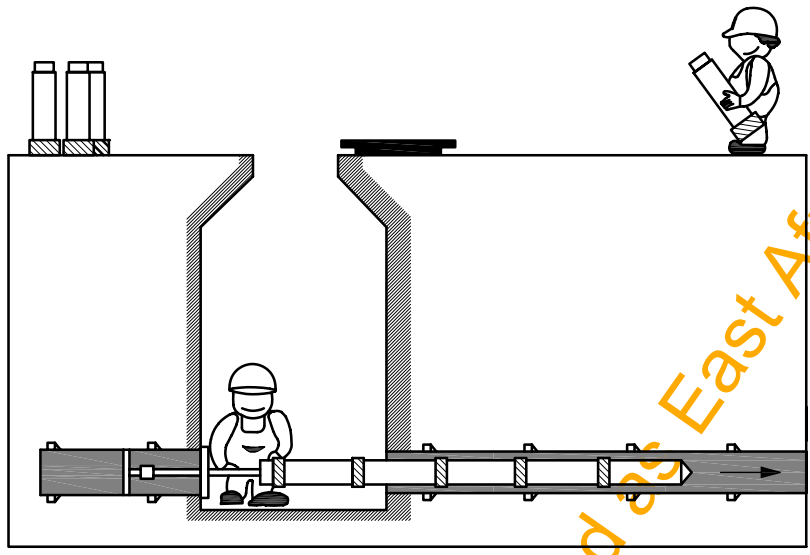

a) Installation by pushing

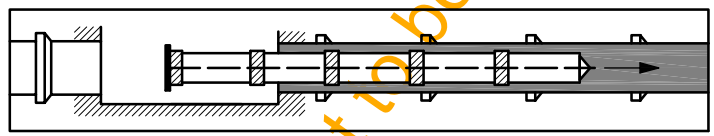

b) Installation by pulling

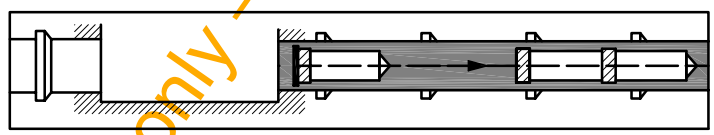

c) Installation by individual pipe placement (typically man-entry only)

Figure 5 — Schematic representation of lining with discrete pipes

NOTE In the following lists, the installation methods illustrated by Figures 5 a), 5 b) and 5 c) are referred to simply as method a), method b) and method c), respectively.

Relevant existing International Standard(s):	<ul style="list-style-type: none"> a) ISO 11296-1; b) ISO 11298-1.
Materials:	PE, PP, PVC-U and GRP.
Applications:	Pressure pipes and non-pressure pipes (drains and sewers, water).
Geometric capabilities:	<ul style="list-style-type: none"> a) non-circular cross-sectional shapes possible; b) typical minimum size <ul style="list-style-type: none"> — methods a) and b): 100 mm; — method c): 800 mm; c) typical maximum size <ul style="list-style-type: none"> — methods a) and b): 600 mm; — method c): 4 000 mm; d) typical maximum length: 150 m; e) bends <ul style="list-style-type: none"> — methods a) and b): bends can generally not be accommodated; — method c): bends with large radii can be accommodated.
Performance:	<ul style="list-style-type: none"> a) reduction in hydraulic capacity significant; b) gradient can be restored using individual pipe placement [method c)]; c) fully structural rehabilitation is possible.
Installation characteristics:	<ul style="list-style-type: none"> a) the type of joint is a significant feature of each technique; b) pipe joints can be locked (end-load-bearing); c) surface working space: no particular constraint; d) short pipe lengths may allow insertion from existing access chambers, otherwise local excavation required; e) technique does not rely on adhesion to host pipe; f) flow interruption/diversion typically required (also for grouting); g) the annular space is typically grouted; h) reconnection of laterals/services: generally requires excavation.

5.6 Lining with adhesive-backed hoses

Lining with adhesive-backed hoses is defined as lining with a reinforced hose which relies on an adhesive bond to the host pipe to provide resistance to collapse (see Figure 6).

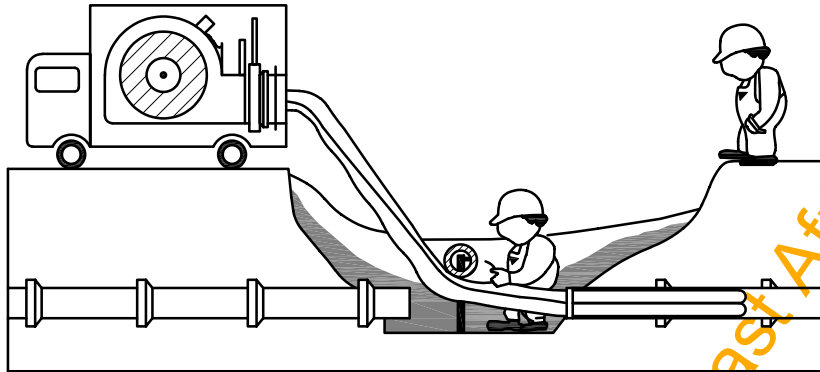
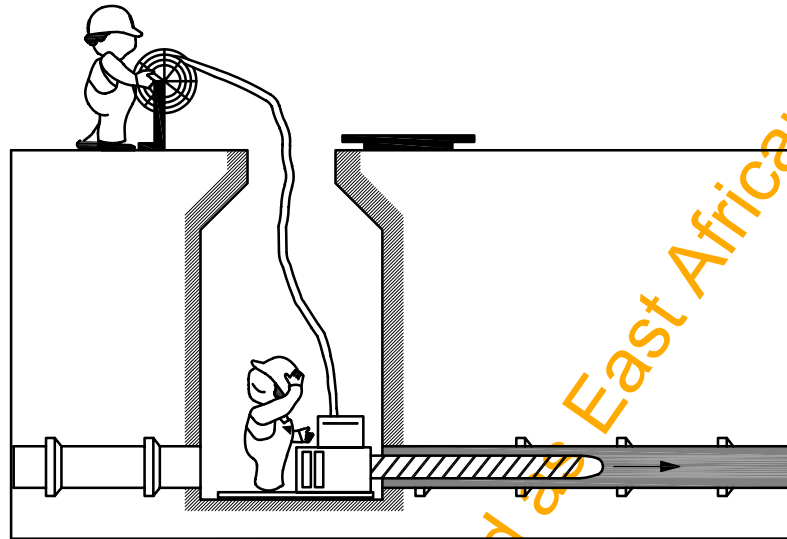

Figure 6 — Schematic representation of lining with adhesive-backed hoses

Relevant existing International Standard(s):	<ul style="list-style-type: none"> a) ISO 11298-1; b) ISO 11299-1.
Materials:	A circular woven hose of PA, PAN, PEN and/or PET fibres, coated on one side with a thermoplastic (e.g. PE) barrier layer and on the other with a thermosetting resin (EP).
Applications:	Pressure pipes (water and gas).
Geometric capabilities:	<ul style="list-style-type: none"> a) typical minimum size: 50 mm; b) typical maximum size: 1 500 mm; c) typical maximum length: 150 m; d) bends can be accommodated.
Performance:	<ul style="list-style-type: none"> a) minimal reduction in capacity; increase in flow possible; b) only semi-structural rehabilitation is possible.
Installation characteristics:	<ul style="list-style-type: none"> a) insertion of the adhesive-backed hose by inversion with air (heat curing of adhesive with steam); b) surface working space generally minimal; c) structural effect relies on adhesion to host pipe; d) flow interruption/diversion typically required; e) re-opening of services from inside is possible; f) creation of a tight connection from inside is possible.

5.7 Lining with spirally-wound pipes

Lining with spirally-wound pipes is defined as lining with a profiled strip, spirally wound to form a continuous pipe after installation (see Figure 7).



a) Installation by winding from the access chamber

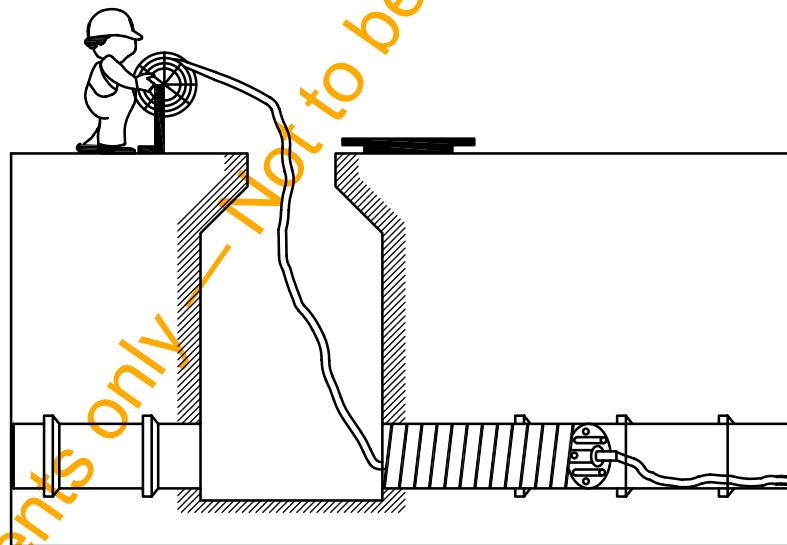

b) Installation by winding from within the pipeline

Figure 7 — Schematic representation of lining with spirally-wound pipes

Relevant existing International Standard(s):	a) ISO 11296-1; b) ISO 11296-7.
Materials:	a) PVC-U, PE; b) additional stiffness enhancing elements.
Applications:	Non-pressure (drains and sewers).
Geometric capabilities:	a) typical minimum size: 150 mm; b) typical maximum size: 3 000 mm; c) typical maximum length: 300 m.
Performance:	a) close-fit and fixed diameter solutions; the latter with significant reduction in capacity; b) fully structural renovation is possible.
Installation characteristics:	a) lining pipe formed on site by <ul style="list-style-type: none">— spirally winding a strip from a machine located in an access chamber, or— spirally winding a strip from a machine from within the host pipe; b) surface working space minimal; c) entry via existing manhole or small excavation possible; d) flow interruption/diversion may be required; e) re-opening of services from inside is possible; f) grouting of annulus required for fixed diameter solutions.

6 Information on design

6.1 General

It is the responsibility of the system owner to either choose and design the renovation system or nominate a competent person to do so. This International Standard provides information for the processes of choice and design.

The steps generally to be followed in the renovation design process are the following:

- a) assess the deficiencies of current performance of the existing pipeline;
- b) identify lining system requirements to achieve the desired functional performance;
- c) determine viable technique options, based on performance classifications and process-related factors;
- d) specify, for each viable technique, the required amount of lining material needed to secure the desired performance of the renovated pipeline.

Steps a) to c) fall within the scope of this International Standard and related information is given in 6.2 to 6.5.

6.2 Condition assessment

6.2.1 General

Apart from investigating deficiencies, the following basic information about the existing pipeline should be obtained:

- a) the pipe material;
- b) the pipe class (e.g. crushing strength, stiffness or pressure class);
- c) the actual internal diameter or other non-circular section dimensions;
- d) the joint type;
- e) the fluid transported;
- f) the frequency of branches and service connections;
- g) the type and location of other fittings;
- h) the year of installation, if available;
- i) the bedding and backfill of original construction, if available;
- j) the service history including any previous repairs, if available.

NOTE 1 Some of this information can be ascertained from records and plans.

NOTE 2 For service activities relating to drinking water and waste water, such as assessment of service to users and management of the utilities, see ISO 24510, ISO 24511 and ISO 24512.

6.2.2 Pipeline condition affecting functional performance

Methods for determining the condition of the existing pipeline differ in some respects for non-pressure and pressure applications and as a function of material, section size and shape.

In the case of non-pressure pipelines, the following information should, wherever possible, be obtained by visual inspection in the form of a high-definition colour closed-circuit television (CCTV) survey or profiling equipment and/or by man-entry, and should be recorded systematically such that the exact location of each feature, condition and defect is known and an assessment of its severity can be made:

- a) geometric features, including:
 - 1) changes in diameter or, for non-circular pipelines, of section size and shape,
 - 2) degree of ovality or other relevant measure of section deformation,
 - 3) radial displacements such as stepped joints, and
 - 4) axial displacements such as pulled joints;
- b) hydraulic condition, such as:
 - 1) leakage,
 - 2) ponding,

- 3) silting, and
 - 4) obstacles to flow such as root growth, encrustations and/or protruding laterals;
- c) structural defects, including:
- 1) cracks/breaks,
 - 2) collapses,
 - 3) abrasion, and
 - 4) corrosion.

NOTE As a result of the CCTV inspection, a more detailed examination can be carried out, requiring local excavations.

In the case of pressure pipelines, where CCTV inspection is not possible for any reason, assessment of geometric and structural condition should be undertaken by other non-destructive methods, which typically vary according to pipe material, or by extraction of pipe samples.

For water supply pipelines, the quantity of any leakage detected should be assessed where this is a factor in renovation design.

6.2.3 Site conditions affecting liner design

The following site conditions should generally be determined:

- a) the depth of cover to existing pipe;
- b) the height of ground water table;
- c) traffic or other surface loads;
- d) any sources of possible future ground movement;
- e) any evidence of deterioration of the surrounding soil, e.g. erosion voids and/or contamination.

NOTE Where the existing pipeline crosses contaminated ground, the resistance of the liner and ancillary material to chemical attack or permeation by contaminants can be considered.

6.2 Lining system functions

Lining system functions generally include one or more of the following:

- a) separation of the inner surface of the existing pipeline from the transported fluid to prevent mutual adverse reactions (barrier function against, for example, corrosion of the existing pipeline by aggressive water);
- b) sealing of the existing pipeline against infiltration of ground water or exfiltration of the transported fluid through leaking joints, cracks or holes;
- c) stabilization or strengthening of the existing pipeline structure to extend its service life (e.g. where corrosion has resulted in loss of structural integrity or to allow for increases in operating pressure or other loads);
- d) providing sufficient hydraulic capacity (e.g. by creating a smooth flow path).

6.4 Performance criteria

6.4.1 Structural performance

6.4.1.1 General

Plastics lining pipes used for renovation have, in general, to withstand both internal and external loads in service and should be designed accordingly.

The short-term and long-term effects of installation loads should also be taken into account. The design should include specifying limits for these installation loads.

In addition, the effects of loads, both internal and external, acting on those parts of the liner which are not wholly contained within the existing pipeline, e.g. in manholes, at broken or missing parts of the existing pipeline, at fittings, joints and lateral connections, should be considered, where applicable.

NOTE Loads acting on a liner and the associated response of the plastics lining system are not generally comparable with those of a flexible pipe buried directly in soil by open excavation. This is because:

- a) the lining pipe is installed without disturbing the existing pipe-soil structure, which at least initially continues to be self-supporting and further limits the potential for transfer of soil load to the liner over time;
- b) lining system response to internal pressure as well as external loads can be either positively or negatively influenced by the presence of the existing pipeline, which cannot therefore be ignored, even if severely deteriorated.

When considering the external loading due to groundwater pressure, the possibilities of short-term saturation of the ground under storm conditions, or even of flood water standing above ground level, should be taken into account.

6.4.1.2 Non-pressure pipes

Plastics lining pipes used for renovation of non-pressure pipelines generally require independent ring stiffness to fulfil their structural function.

NOTE 1 Minimum short-term ring stiffness is specified as a function of pipe material in the technique-related parts of ISO 11296. The minimum short-term ring stiffness for each technique family is intended to reflect a minimum long-term load capability to resist a sustained water head of 1 m above pipe invert.

Loads that should generally be considered include the following, as applicable:

- a) installation loads, including
 - 1) lining pipe preparation forces (e.g. section reduction and spiral winding),
 - 2) insertion forces (tensile, compressive, bending and torsion),
 - 3) reversion forces (pressure and thermal),
 - 4) grouting forces (external pressure and flotation),
 - 5) residual effects of the above installation forces in the permanent works;
- b) internal loads, including
 - 1) surcharge pressure, and
 - 2) thermal loads due to temperature of transported fluid;

- c) external loads, including
 - 1) ground water pressure, and/or negative pressure (vacuum),
 - 2) transferred soil loads, from overburden soil weight and traffic surcharge,
 - 3) ground movements, from differential settlement, frost action and earthquakes,
 - 4) point loads, from irregularities of the existing pipeline, and
 - 5) thermal loads due to the environment.

NOTE 2 The resistance to buckling under groundwater pressure and/or negative pressure (vacuum) of a close-fitting liner (or where any annular space is grouted) is significantly enhanced by radial support from the existing pipeline compared with the resistance of a loose-fitting liner.

6.4.1.3 Pressure pipes

Pressure pipe liners serve primarily to contain internal pressure, but are also generally subjected to external loads. The structural action of pressure pipe liners is classified as indicated in Table 1.

NOTE This International Standard is not applicable to non-structural Class D liners.

Table 1 — Structural classification of pressure pipe liners

Liner characteristics	Class A	Class B	Class C	Class D
Can survive internally or externally induced (burst, bending or shear) failure of host pipe	✓	—	—	—
Long-term pressure rating ≥ maximum allowable operating pressure (MAOP)	✓	—	—	—
Inherent ring stiffness ^a	✓	✓	— ^b	— ^b
Long-term hole and gap spanning at MAOP	✓	✓ ^c	✓	—
Provides internal barrier layer ^d	✓	✓	✓	✓

^a The minimum requirement is for the liner to be self-supporting when pipe is depressurized.
^b The liner relies on adhesion to the host pipe to be self-supporting when depressurized.
^c The liner becomes sufficiently close-fit for radial transfer of internal pressure stress to the host pipe, either during installation or within a short period from initial application of operating pressure.
^d The liner serves as barrier to the corrosion, abrasion and/or tuberculation/scaling of the host pipe and to the contamination of the pipe contents by the host pipe; it also generally reduces surface roughness for improved flow capacity.

An independent (Class A) pressure pipe liner is, by definition, capable on its own of resisting, without failure, all applicable internal loads throughout its design life, without relying on the existing pipeline for radial support. When tested independently from the host pipe, it should exhibit long-term 50-year internal pressure strength equal to or greater than the MAOP of the rehabilitated pipeline. An independent pressure pipe liner may be a loose-fitting or close-fitting installation (see Figure 8).

An interactive (Class B or C) pressure pipe liner is, by definition, not capable on its own of resisting, without failure, all applicable internal loads throughout its design life, and therefore relies on the existing pipeline for some measure of radial support. A liner is considered interactive if, when tested independently from the host pipe, the long-term pressure strength is less than the MAOP of the rehabilitated pipeline. An interactive pressure pipe liner is a close-fitting installation (see Figure 8).

The ring stiffness properties of independent and interactive pipe liners should be assessed to determine their resistance to buckling under the action of external hydrostatic or internal vacuum forces. Liners should be at

least self-supporting when depressurized, but may require additional stiffness enhancement or incorporate pipe wall adhesion systems to resist specific vacuum loads in service and/or external groundwater loads applicable during any period that the pipeline is out of service.

Where connections, e.g. ferrules or service taps, are to form part of the renovated pressure pipe at any time, the design of the lining system, in respect of external loading, should ensure that either

- a) the liner does not collapse under conditions of simultaneous maximum groundwater pressure and negative internal pressure (vacuum), or
- b) the design of the connection fitting is such that it maintains full integrity with the liner when collapsed. Such integrity should apply to both sealing to the liner and mechanical attachment to the host pipe.

NOTE 1 A close-fitting liner pipe in service remains in radial contact with the wall of the existing pipe and the consequent interaction between the liner and the host pipe results in the transfer of internal pressure loads onto the host pipe. The rate of transfer is dependent on the initial liner strain and the stress relaxation properties of the liner material. Pressure loading of the host pipe can be minimized by appropriate combinations of liner strain and stress relaxation effects.

NOTE 2 Self-supporting liners are considered to be more capable of resisting joint and/or ground movements, as well as external groundwater pressure, than liners which depend entirely on adhesion to the pipe wall to prevent collapse (see Figure 8).

For all liners, whether loose-fitting independent, close-fitting independent or interactive, as defined in this International Standard, due consideration should be given to any requirements for support of longitudinal and lateral pressurization forces at bends or other changes of alignment.

Figure 8 illustrates the classification of independent and interactive pressure pipe liners.

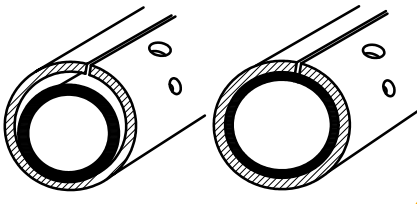
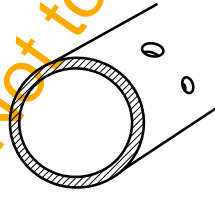
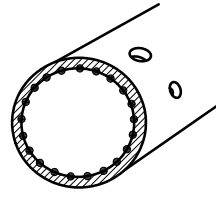
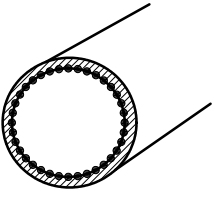
Class A		Class B	Class C	Class D
				
loose-fit	close-fit	inherent ring stiffness	relies on adhesion	relies on adhesion
Independent		Interactive		
Fully structural		Semi-structural		Non-structural
Lining with continuous pipes				This International Standard is not applicable
	Lining with close-fit pipes			
	Lining with cured-in-place pipes			
		Lining with adhesive-backed hoses		

NOTE Dots in illustrations for Classes C and D depict adhesion.

Figure 8 — Structural classification of pressure pipe liners and correspondence to technique families within the scope of this International Standard

Loads that should generally be considered include the following, as applicable:

- a) installation loads, including
 - 1) lining pipe preparation forces (e.g. section reduction),
 - 2) insertion forces (tensile, compressive, bending and torsion),
 - 3) reversion forces (pressure and thermal),
 - 4) grouting forces (external pressure and flotation), and
 - 5) residual effects of the above installation forces in the permanent works;
- b) internal loads, including
 - 1) design and operating pressures (long-term),
 - 2) test pressure,
 - 3) pressure transients, positive and negative (e.g. water hammer, pressure cycling and vacuum), and
 - 4) thermal loads due to temperature of transported fluid;
- c) external loads, including
 - 1) transferred soil loads, from overburden soil weight and traffic surcharge,
 - 2) ground movements, from differential settlement, frost action and earthquakes,
 - 3) point loads from irregularities of the existing pipeline,
 - 4) thermal loads due to the environment, and
 - 5) groundwater pressure and/or negative pressure (vacuum).

NOTE 3 The resistance to buckling under groundwater pressure and/or negative pressure (vacuum) of a close-fitting liner (or where any annular space is grouted) is significantly enhanced by radial support from the existing pipeline compared with the resistance of a loose-fitting liner.

6.4.2 Hydraulic performance

Requirements for the fluid carrying capacity of the installed lining system should be agreed on with the client, taking into consideration the expected service life of the installation. The design assumptions made in the fluid capacity calculations should be documented, e.g. in the installation manual.

Determining the hydraulic capacity really needed from the system can be a key factor in the selection of the most economic renovation technique. The required capacity fixes the minimum internal dimensions of the installed liner, its maximum external dimensions being fixed by the existing pipe (which either may or may not be of circular cross-section). Any additional benefits of hydraulic smoothness and continuity of invert provided by the lining system should be taken into account.

6.5 Other factors affecting lining system selection

Lining system selection for any given application will also generally depend on site conditions affecting installation, such as available working space and constraints on environmental impact. For further information of both a general nature and specific to individual technique families, see Annex A.

Another factor to be considered, especially in pressure applications, is the reconnection of renovated sections of pipeline to the remainder of the existing network.

Some renovation systems use lining pipes which differ from standard pipes in diameter and wall thickness or which are physically deformed at some stage of the renovation process, for instance by reducing or folding. In such cases, the integrity of fittings should be demonstrated by testing with the relevant lining pipe and renovation system in the installed condition.

Where the renovation system requires fittings to have full end-load capability, this should be tested to demonstrate a design life at least equalling that of the renovation system itself.

Draft for comments only — Not to be cited as East African Standard

Annex A (informative)

Process-related aspects

A.1 Site conditions affecting installation

A.1.1 Working space requirements

The various renovation techniques have different working space requirements. These can affect the choice of technique depending on the local conditions, especially:

- a) access to the site;
- b) access to the existing pipeline, including
 - 1) through existing manholes,
 - 2) by local excavation, and
 - 3) by means of robots (e.g. for laterals);
- c) access to existing laterals/services for external reconnection;
- d) surface area available for
 - 1) equipment (cleaning, inspection and installation),
 - 2) preparation and insertion of the lining pipe, and
 - 3) temporary storage (lining pipe, processing materials and waste).

A.1.2 Environmental impact

The extent of environmental impact depends on

- a) local excavation (frequency, size, etc.),
- b) working equipment (noise, fumes, dust, agricultural damage, etc.),
- c) handling of waste (from cleaning, local excavations, process materials, offcuts, etc.),
- d) effect on traffic, and
- e) choice of process materials (lubricants, hydraulic oils, resins, adhesives, etc.).

NOTE Attention is drawn to any national legislation relating to environmental impact.

A.1.3 Assessment of site conditions

A survey of site conditions relevant to lining system selection should generally determine and record the following:

- a) access to existing pipe, including
 - 1) depth of cover,
 - 2) manhole or excavation,
 - 3) available working area at access points,
 - 4) traffic – both vehicular and pedestrian, and
 - 5) proximity of other services;
- b) construction constraints, including
 - 1) ground water table,
 - 2) section and/or reach lengths,
 - 3) gradients,
 - 4) changes in direction,
 - 5) junctions,
 - 6) laterals/services,
 - 7) provision for continuity of pipeline service, and
 - 8) availability of water supply where required by the lining process.

Much of this information can be obtained initially from records and plans, but should always be confirmed by site inspection.

A.2 Work preparatory for installation

A.2.1 General

This clause summarizes preparatory work generally required, regardless of application or chosen lining system. For further information relevant to installation of specific technique families, see A.3.

A.2.2 Location of existing pipeline system

The existing pipeline system, comprising all components, should be surveyed in detail and the location and depth of all access points, branches, connections and other fittings recorded. Where relevant, the survey should also include the location of other underground apparatus.

A.2.3 Dimensions of existing pipeline system

The relevant dimensions, i.e. length, actual internal diameter, etc., of the existing pipeline system comprising all components should be documented. This should be by direct measurement.

A.2.4 Provision for maintenance of pipeline service

The survey should identify the need to bypass flows (in the case of drains and sewers) or to provide a temporary supply (water or gas) during renovation works.

In the case of drinking water, the quality of the transported water and the means by which it is carried (bowser, tanker, bypass pipe, etc.) should comply with the relevant national requirements.

A.2.5 Preparation of existing pipeline

Prior to lining, any local obstructions to installation should be removed and any necessary repairs, e.g. to locally collapsed or excessively deformed sections of pipe or holes in the pipe wall, should be completed. Immediately prior to lining, the existing pipeline system should be checked and cleaned, e.g. by jetting, pigging or scraping.

If contamination has been identified, appropriate steps to ensure adequate remediation or protection should be taken.

A.3 Features specific to each technique family

A.3.1 General

This clause provides an overview of the key process-related aspects of the various renovation technique families under the following headings:

- a) installation equipment;
- b) surface area requirement;
- c) excavation requirement.

This annex does not provide comprehensive lists of installation equipment. For additional details, including details of reconnection techniques, see the relevant technique-related part of each application area standard.

A.3.2 Lining with continuous pipes

The following equipment is required:

- a) installation equipment
 - 1) rollers to support the entire length of the lining pipe string (except where pipe is inserted directly from a coil),
 - 2) pushing unit, if applicable,
 - 3) rollers to guide the lining pipe into the existing pipeline,
 - 4) winch with trench mast to pull the lining pipe through the existing pipeline,
 - 5) jointing equipment appropriate to the material, and
 - 6) grouting equipment, if applicable;
- b) surface area requirements
 - 1) for the lining pipe string (or coil trailer for smaller diameters) at the insertion end, and
 - 2) for a winch at the receiving end;

- c) excavation requirements
 - 1) at the insertion end:
 - i) long enough to allow the lining pipe to enter the existing pipeline, taking account of the permissible minimum bending radius;
 - ii) wide enough for the guidance equipment and pushing equipment if applicable;
 - 2) at the receiving end:
 - i) large enough to accommodate the lining pipe nose cone and the trench mast, if applicable.

A.3.3 Lining with close-fit pipes

The following equipment is required:

- a) installation equipment
 - 1) rollers to support the entire length of the lining pipe string (except where pipe is inserted directly from a coil),
 - 2) rollers to guide the lining pipe into the existing pipeline,
 - 3) winch with trench mast to pull the lining pipe through the existing pipeline,

NOTE 1 Where reducing or folding is carried out simultaneously with insertion, winching forces can be high, necessitating substantial anchoring of winch and reducing or folding equipment.

- 4) a compressor and a steam generator (where applicable), for lining pipe reversion, and
- 5) jointing equipment appropriate to material;
- b) surface area requirements
 - 1) for the lining pipe string (or coil trailer for smaller diameters and/or folded pipe) at the insertion end,
 - 2) for reducing or folding equipment at the insertion end where reduction or folding is carried out simultaneously with insertion,
 - 3) for a winch at the receiving end, and
 - 4) for reversion equipment;
- c) excavation requirements
 - 1) at the insertion end:
 - i) long enough to allow the lining pipe to enter the existing pipeline, taking account of the permissible minimum bending radius;
 - ii) wide enough for the guidance equipment and pushing equipment, if applicable;
 - 2) at the receiving end:
 - i) large enough to accommodate the lining pipe nose cone and the trench mast, if applicable.

NOTE 2 Folded lining pipes can generally be inserted through existing manholes.

A.3.4 Lining with cured-in-place pipes

The following equipment is required:

- a) installation equipment
 - 1) lining pipe delivery unit, including conveyor system, if applicable,
 - 2) site impregnation unit, if applicable,
 - 3) for inverted-in-place systems: water column or air compressor,
 - 4) for winched-in-place systems: winch, and
 - 5) water boiler or steam generator for heat curing, or equipment including power supply for UV or electrical curing;
- b) surface area requirement
 - 1) for lining pipe delivery unit immediately adjacent to the insertion access,
 - 2) for site impregnation unit, if applicable,
 - 3) for inversion or winching equipment, and
 - 4) for curing equipment;
- c) excavation requirements
 - 1) not generally necessary for sewer applications, where access through existing manholes is sufficient due to flexibility of the uncured lining pipe, and
 - 2) small excavations at both ends for other applications.

A.3.5 Lining with discrete pipes

The following equipment is required:

- a) installation equipment
 - 1) pipe handling equipment, and
 - 2) generator to power pipe jacking equipment;

NOTE The jacking equipment can be chosen to fit existing access, which will in turn determine the maximum length of pipe which can be used.

- b) surface area requirements
 - 1) for storage of pipes,
 - 2) for pipe handling equipment, and
 - 3) for a generator to power the pipe jacking equipment;

- c) excavation requirements
 - 1) not generally necessary for sewer applications, access through manhole due to availability of short pipe lengths,
 - 2) for other applications, excavation large enough to accommodate jacking equipment at the insertion end, and
 - 3) man-entry access needed at receiving end.

A.3.6 Lining with adhesive-backed hoses

The following equipment is required:

- a) installation equipment
 - 1) at the insertion end, guide rollers,
 - 2) at the receiving end, winch with trench mast, and
 - 3) a compressor or pre-compressed gas and steam generator for hose reversion, if applicable;
- b) surface area requirements
 - 1) for drums of lining hose at the insertion end,
 - 2) for a winch at the receiving end, if applicable, and
 - 3) for reversion equipment, if applicable;
- c) excavation requirements
 - 1) small access excavation sufficient due to flexibility of hose.

A.3.7 Lining with spirally-wound pipes

The following equipment is required:

- a) installation equipments
 - 1) strip winder, and
 - 2) grouting equipment;
- b) surface area requirements
 - 1) for drums of liner strip at the insertion end, and
 - 2) for a generator to power the winder at the insertion end;
- c) excavation requirements
 - 1) manhole access sufficient due to flexibility of lining strip and small size of the winder.

Bibliography

- [1] ISO 11296-1, *Plastics piping systems for renovation of underground non-pressure drainage and sewerage networks — Part 1: General*
- [2] ISO 11296-3, *Plastics piping systems for renovation of underground non-pressure drainage and sewerage networks — Part 3: Lining with close-fit pipes*
- [3] ISO 11296-4, *Plastics piping systems for renovation of underground non-pressure drainage and sewerage networks — Part 4: Lining with cured-in-place pipes*
- [4] ISO 11296-7, *Plastics piping systems for renovation of underground non-pressure drainage and sewerage networks — Part 7: Lining with spirally-wound pipes¹⁾*
- [5] ISO 11298-1, *Plastics piping systems for renovation of underground water supply networks — Part 1: General*
- [6] ISO 11298-3, *Plastics piping systems for renovation of underground water supply networks — Part 3: Lining with close-fit pipes*
- [7] ISO 11299-1, *Plastics piping systems for renovation of underground gas supply networks — Part 1: General¹⁾*
- [8] ISO 11299-3, *Plastics piping systems for renovation of underground gas supply networks — Part 3: Lining with close-fit pipes¹⁾*
- [9] ISO 24510, *Activities relating to drinking water and wastewater services — Guidelines for the assessment and for the improvement of the service to users*
- [10] ISO 24511, *Activities relating to drinking water and wastewater services — Guidelines for the management of wastewater utilities and for the assessment of wastewater services*
- [11] ISO 24512, *Activities relating to drinking water and wastewater services — Guidelines for the management of drinking water utilities and for the assessment of drinking water services*
- [12] EN 13566-2, *Plastics piping systems for renovation of underground non-pressure drainage and sewerage networks — Part 2: Lining with continuous pipes*

1) Under preparation.

Draft for comments only — Not to be cited as East African Standard

ICS 23.040.01

Price based on 28 pages

Draft for comments only — Not to be cited as East African Standard