



CD/K/009:2009
ICS 77.140.75; 91.140.40; 91.140.60

EAST AFRICAN STANDARD

Ductile iron pipes, fittings, accessories and their joints for water pipelines — Requirements and test methods

EAST AFRICAN COMMUNITY

Foreword

Development of the East African Standards has been necessitated by the need for harmonizing requirements governing quality of products and services in East Africa. It is envisaged that through harmonized standardization, trade barriers which are encountered when goods and services are exchanged within the Community will be removed.

In order to meet the above objectives, the EAC Partner States have enacted an East African Standardization, Quality Assurance, Metrology and Test Act, 2006 (EAC SQMT Act, 2006) to make provisions for ensuring standardization, quality assurance, metrology and testing of products produced or originating in a third country and traded in the Community in order to facilitate industrial development and trade as well as helping to protect the health and safety of society and the environment in the Community.

East African Standards are formulated in accordance with the procedures established by the East African Standards Committee. The East African Standards Committee is established under the provisions of Article 4 of the EAC SQMT Act, 2006. The Committee is composed of representatives of the National Standards Bodies in Partner States, together with the representatives from the private sectors and consumer organizations. Draft East African Standards are circulated to stakeholders through the National Standards Bodies in the Partner States. The comments received are discussed and incorporated before finalization of standards, in accordance with the procedures of the Community.

Article 15(1) of the EAC SQMT Act, 2006 provides that "Within six months of the declaration of an East African Standard, the Partner States shall adopt, without deviation from the approved text of the standard, the East African Standard as a national standard and withdraw any existing national standard with similar scope and purpose".

East African Standards are subject to review, to keep pace with technological advances. Users of the East African Standards are therefore expected to ensure that they always have the latest versions of the standards they are implementing.

© East African Community 2010 — All rights reserved*

East African Community

P O Box 1096

Arusha

Tanzania

Tel: 255 27 2504253/8

Fax: 255-27-2504481/2504255

E-Mail: eac@eachq.org

Web: www.each.int

Introduction

In the preparation of this East African Standard, the following source was consulted extensively:

ISO 2531:2009, *Ductile iron pipes, fittings, accessories and their joints for water applications*

Assistance derived from this source and others inadvertently not mentioned is hereby acknowledged.

Draft for comments only — Not to be cited as East African Standard

INTERNATIONAL
STANDARD

ISO
2531

Sixth edition
2009-12-15

**Ductile iron pipes, fittings, accessories
and their joints for water applications**

*Tuyaux, raccords et accessoires en fonte ductile et leurs assemblages
pour l'eau*

Draft for comments only — Not to be cited as East African Standard



Reference number
ISO 2531:2009(E)

© ISO 2009

PDF disclaimer

This PDF file may contain embedded typefaces. In accordance with Adobe's licensing policy, this file may be printed or viewed but shall not be edited unless the typefaces which are embedded are licensed to and installed on the computer performing the editing. In downloading this file, parties accept therein the responsibility of not infringing Adobe's licensing policy. The ISO Central Secretariat accepts no liability in this area.

Adobe is a trademark of Adobe Systems Incorporated.

Details of the software products used to create this PDF file can be found in the General Info relative to the file; the PDF-creation parameters were optimized for printing. Every care has been taken to ensure that the file is suitable for use by ISO member bodies. In the unlikely event that a problem relating to it is found, please inform the Central Secretariat at the address given below.



COPYRIGHT PROTECTED DOCUMENT

© ISO 2009

All rights reserved. Unless otherwise specified, no part of this publication may be reproduced or utilized in any form or by any means, electronic or mechanical, including photocopying and microfilm, without permission in writing from either ISO at the address below or ISO's member body in the country of the requester.

ISO copyright office
Case postale 56 • CH-1211 Geneva 20
Tel. + 41 22 749 01 11
Fax + 41 22 749 09 47
E-mail copyright@iso.org
Web www.iso.org

Published in Switzerland

Contents

Page

Foreword	iv
1 Scope	1
2 Normative references	1
3 Terms and definitions	2
4 Technical requirements	5
4.1 General	5
4.2 Pressure classification and dimensional requirements	7
4.3 Material characteristics	11
4.4 Coating and linings for pipes	12
4.5 Coatings and linings for fittings and accessories	13
4.6 Marking	13
5 Leaktightness requirements	13
5.1 Pipes and fittings	13
5.2 Flexible joints	13
5.3 Flanged joints as cast, screwed, welded and adjustable	15
6 Test methods	17
6.1 Dimensions	17
6.2 Straightness of pipes	17
6.3 Tensile test	17
6.4 Brinell hardness	19
6.5 Works leaktightness test of pipes and fittings	20
7 Type tests	20
7.1 Leaktightness of joints to internal pressure	20
7.2 Leaktightness of joints to external pressure	21
7.3 Leaktightness of joints to negative internal pressure	22
7.4 Leaktightness and mechanical resistance of flanged joints	22
8 Tables of dimensions	23
8.1 Socket and spigot pipes	23
8.2 Flanged pipes	25
8.3 Fittings for socketed joints	25
8.4 Fittings for flanged joints	41
Annex A (informative) External protection	59
Annex B (informative) Internal protection	60
Annex C (informative) Dimensions of preferred pressure classes and other pressure class pipes	61
Annex D (normative) Pipe wall thicknesses, stiffness and diametral deflection	63
Annex E (normative) Quality assurance	71
Annex F (informative) Safety factors	72
Bibliography	73

Foreword

ISO (the International Organization for Standardization) is a worldwide federation of national standards bodies (ISO member bodies). The work of preparing International Standards is normally carried out through ISO technical committees. Each member body interested in a subject for which a technical committee has been established has the right to be represented on that committee. International organizations, governmental and non-governmental, in liaison with ISO, also take part in the work. ISO collaborates closely with the International Electrotechnical Commission (IEC) on all matters of electrotechnical standardization.

International Standards are drafted in accordance with the rules given in the ISO/IEC Directives, Part 2.

The main task of technical committees is to prepare International Standards. Draft International Standards adopted by the technical committees are circulated to the member bodies for voting. Publication as an International Standard requires approval by at least 75 % of the member bodies casting a vote.

Attention is drawn to the possibility that some of the elements of this document may be the subject of patent rights. ISO shall not be held responsible for identifying any or all such patent rights.

ISO 2531 was prepared by Technical Committee ISO/TC 5, *Ferrous metal pipes and metallic fittings*, Subcommittee SC 2, *Cast iron pipes, fittings and their joints*.

This sixth edition cancels and replaces the fifth edition (ISO 2531:1998), of which it constitutes a technical revision. A new classification system for pipes and fittings based on pressure is introduced with minimum wall thickness determined by allowable operating pressure.

Ductile iron pipes, fittings, accessories and their joints for water applications

1 Scope

This International Standard specifies the requirements and test methods applicable to ductile iron pipes, fittings, accessories and their joints for the construction of pipelines:

- to convey water (e.g. for human consumption and raw water),
- operated with or without pressure, and
- installed below or above ground.

NOTE In this International Standard, all pressures are relative pressures expressed in bar¹⁾.

This International Standard specifies materials, dimensions and tolerances, mechanical properties and standard coatings of pipes, fittings and accessories. It also gives performance requirements for all components including joints.

This International Standard applies to pipes, fittings and accessories cast by any type of foundry process or manufactured by fabrication of cast components, as well as corresponding joints in the size range DN 40 to DN 2600 inclusive.

It is applicable to pipes, fittings and accessories which are

- manufactured with socketed, flanged or spigot ends (joint design and gasket shapes are outside the scope of this International Standard),
- normally delivered internally and externally coated.

Pipes and fittings are classified according to allowable operating pressure.

2 Normative references

The following referenced documents are indispensable for the application of this document. For dated references, only the edition cited applies. For undated references, the latest edition of the referenced document (including any amendments) applies.

ISO 4016, *Hexagon head bolts — Product grade C*

ISO 4034, *Hexagon nuts — Product grade C*

ISO 4633, *Rubber seals — Joint rings for water supply, drainage and sewerage pipelines — Specification for materials*

ISO 6506-1, *Metallic materials — Brinell hardness test — Part 1: Test method*

ISO 7005-2, *Metallic flanges — Part 2: Cast iron flanges*

1) 100 kPa = 1 bar

ISO 7091, *Plain washers — Normal series — Product grade C*

ISO 10803, *Design method for ductile iron pipes*

ISO 10804, *Restrained joint systems for ductile iron pipelines — Design rules and type testing*

EN 1092-2, *Flanges and their joints — Circular flanges for pipes, valves, fittings and accessories, PN designated — Part 2: Cast iron flanges*

3 Terms and definitions

For the purposes of this document, the following terms and definitions apply.

3.1

accessory

any casting other than a pipe or fitting, which is used in a pipeline

EXAMPLE 1 Glands and bolts for mechanical flexible joints (see 3.18).

EXAMPLE 2 Glands, bolts and locking rings or segments for restrained joints (see 3.24).

NOTE The term accessory is not relevant for valves or hydrants of any type.

3.2

allowable operating pressure

PFA

maximum internal pressure, excluding surge, which a component can safely withstand in permanent service

3.3

allowable site test pressure

PEA

maximum hydrostatic pressure that a newly installed component can withstand for a relatively short duration, when either fixed above ground level or laid and backfilled underground, in order to measure the integrity and tightness of the pipeline

NOTE This test pressure is different from the system test pressure, which is related to the design pressure of the pipeline.

3.4

batch

quantity of castings from which a sample may be taken for testing purposes during manufacture

3.5

component

any product defined as an element of a pipe, fitting or accessory

See 3.1, 3.9 and 3.22.

3.6

deviation

amount by which the design length may differ from the standardized length of a pipe or a fitting

NOTE Pipes and fittings are designed to a length selected in the range of standard length plus or minus the deviation (see Table 6); they are manufactured to this length plus or minus the tolerance given in Table 7.

3.7

diametral stiffness of a pipe

characteristic of a pipe allowing it to resist diametral deflection under loading

3.8**ductile iron**

type of cast iron used for pipes, fittings and accessories in which graphite is present primarily in spheroidal form

3.9**fitting**

casting other than a pipe, which allows pipeline deviation, change of direction or bore

NOTE Flanged sockets, flanged spigots and collars are also classified as fittings.

3.10**flange**

end of a pipe or fitting, extending perpendicular to its axis, with bolt holes equally spaced in a circle

NOTE A flange can be fixed (e.g. integrally cast, screwed-on or welded-on) or adjustable. An adjustable flange comprises a ring, in one or several parts bolted together, which bears on an end joint hub and which can be freely rotated around the barrel axis before jointing.

3.11**flanged joint**

joint between two flanged ends

3.12**flexible joint**

joint providing significant angular deflection and movement parallel and/or perpendicular to the pipe axis

3.13**gasket**

sealing component of a joint

3.14**hoop stress**

σ

stress in a pipe or fitting under pressure, acting tangentially to the perimeter of a transverse section

3.15**joint**

connection between the ends of pipes and/or fittings in which a gasket is used to effect a seal

3.16**laying length**

L_e

length by which a pipeline progresses when an additional pipe is installed

NOTE 1 For socket and spigot pipes, it is equal to the total length of the pipe, L_{tot} , minus the maximum spigot insertion depth, L_i , as given by the manufacturer and as shown in Figure 4. For flanged pipes, it is equal to the total length of the pipe.

NOTE 2 It is expressed in metres.

3.17**maximum allowable operating pressure**

PMA

maximum internal pressure, including surge, which a component can safely withstand in service

3.18**mechanical flexible joint**

flexible joint in which sealing is obtained by applying pressure to the gasket by mechanical means

EXAMPLE A gland.

3.19
nominal pressure
PN

numerical designation, which is a convenient rounded number, used for reference purposes

NOTE 1 All components of the same nominal size, DN, designated by the same PN number have compatible mating dimensions.

NOTE 2 Adapted from ISO 7268.

3.20
nominal size
DN

alphanumeric designation of size for components of a pipework system, which is used for reference purposes

NOTE 1 It comprises the letters DN followed by a dimensionless whole number, which is indirectly related to the physical size, in millimetres, of the bore or outside diameter of the end connections.

NOTE 2 Adapted from ISO 6708:1995, definition 2.1.

3.21
ovality

out-of-roundness of a pipe section, equal to Equation (1)

$$100 \frac{(A_1 - A_2)}{(A_1 + A_2)} \quad (1)$$

where

A_1 is the maximum axis, in millimetres;

A_2 is the minimum axis, in millimetres.

3.22
pipe

casting of uniform bore, with straight axis, having either socket, spigot or flanged ends

NOTE This does not apply to flanged sockets, flanged spigots and collars, which are classified as fittings.

3.23
push-in flexible joint

flexible joint assembled by pushing the spigot through the gasket into the socket of the mating component

3.24
restrained joint

joint in which a means is provided to prevent separation of the assembled joint

3.25
socket

female end of a pipe or fitting to make the connection with the spigot of the next component

3.26
spigot

male end of a pipe or fitting

3.27**spigot end**

maximum insertion depth of the spigot, L_i , plus 50 mm

See L_i in Figure 4.

3.28**standardized length**

length of pipe barrel and fitting body or branch as defined in this International Standard

NOTE 1 For socket and spigot pipes, and fittings, it is designated L_u (l_u for branches). For flanged pipes, and fittings, it is designated L (l for branches). See Figures 4 to 27.

NOTE 2 For flanged pipes and fittings, the standardized length L (l for branches) is equal to the total length. For socketed pipes and fittings, the standardized length L_u (l_u for branches) is equal to the total length minus the spigot insertion depth, as indicated in the manufacturer's catalogues.

3.29**type test**

proof-of-design test, which is done once and is repeated only after change of design

4 Technical requirements**4.1 General****4.1.1 Pipes and fittings**

Thicknesses, lengths and coatings are specified in this subclause, 4.2.3, 4.2.4 and 4.4 for pipes, and 4.5 for fittings. When, by agreement between the manufacturer and the purchaser, pipes and fittings with different lengths, thicknesses and/or coatings, and other types of fittings than those given in 8.3 and 8.4, are supplied in accordance with this International Standard, they shall comply with all the other requirements of this International Standard. This includes pipe and fittings manufactured to national standards and regulations.

The standard nominal sizes, DN, of pipes and fittings are the following:

40, 50, 60, 65, 80, 100, 125, 150, 200, 250, 300, 350, 400, 450, 500, 600, 700, 800, 900, 1000, 1100, 1200, 1400, 1500, 1600, 1800, 2000, 2200, 2400 and 2600.

The stiffness and allowable diametral deflection of ductile iron pipes are as given in Annex D.

NOTE When installed and operated under the conditions for which they are designed (see Annexes A and B), ductile iron pipes, fittings, accessories and their joints maintain all their functional characteristics over their operating life, due to constant material properties, to the stability of their cross-section and to their design with high safety factors.

4.1.2 Surface condition and repairs

Pipes, fittings and accessories shall be free from defects and surface imperfections which could impair their compliance with the requirements of Clauses 4 and 5.

When necessary, pipes and fittings may be repaired, for example by welding, to remove surface imperfections and localized defects which do not affect the entire wall thickness, provided that the repaired pipes and fittings comply with all the requirements of Clauses 4 and 5.

4.1.3 Types of joints and interconnection

4.1.3.1 General

Joint design and gasket shapes are beyond the scope of this International Standard.

Rubber gasket materials shall conform to the requirements of ISO 4633 for water applications. When materials other than rubber are necessary (e.g. high-temperature flanged joints), they shall conform to the appropriate International Standards.

4.1.3.2 Flanged joints

Flanged joints shall be designed to facilitate attachment to flanges whose dimensions and tolerances comply with ISO 7005-2 or EN 1092-2. This ensures interconnection between all flanged components (pipes, fittings, valves, etc.) of the same DN and PN and adequate joint performance. Bolts and nuts shall comply, as a minimum, with the requirements of ISO 4016 and ISO 4034, property class 4.6. Where washers are required, they shall comply with ISO 7091.

In addition, each type of flange joint shall be designed to meet the performance requirements of 5.3.

Although it does not affect interconnection, the manufacturer shall indicate in his handbook whether his products are normally delivered with fixed flanges or loose flanges.

4.1.3.3 Flexible joints

Pipes and fittings with flexible joints shall be in accordance with 4.2.2.1 for their spigot external diameters, DE, and their tolerances. This provides the possibility of interconnection between components equipped with different types of flexible joints. In addition, each type of flexible joint shall be designed to meet the performance requirements of 5.2.

For interconnection with certain types of joints operating within a tighter tolerance range on DE, the manufacturer's guidance should be followed as to the means of ensuring adequate joint performance up to the highest pressures (e.g. measurement and selection of external diameter).

For interconnection with existing pipelines which can have external diameters not in accordance with 4.2.2.1, the manufacturer's guidance should be followed as to the appropriate means of interconnection (e.g. adaptors).

4.1.3.4 Restrained joints

Restrained joints for ductile iron pipelines shall be designed in accordance with ISO 10804. Their spigot external diameters, DE, and their tolerances shall comply with 4.2.2.1.

4.1.4 Materials in contact with water intended for human consumption

When used under the conditions for which they are designed, in permanent or in temporary contact with water intended for human consumption, ductile iron pipes, fittings and their joints shall not have detrimental effects on the properties of that water for its intended use.

Ductile iron pipeline systems, including pipes, fittings, accessories and joints, consist of various materials. When used for conveying water intended for human consumption, the materials in contact with the water shall meet the relevant requirements of the national standards or regulations in the country of use with respect to effect on water quality.

4.2 Pressure classification and dimensional requirements

4.2.1 Pressure classifications

4.2.1.1 General

Components with flexible joints shall be classified by the allowable operating pressure (PFA) in bar, prefixed by the letter C.

Components with flanged joints shall be classified by the PN number of the flange.

Allowable component pressure relationships shall be the following:

- a) Allowable operating pressure (PFA) = C, in bar
- b) Allowable maximum operating pressure (PMA) = $1,20 \times \text{PFA}$, in bar
- c) Allowable site test pressure (PEA) = $(1,20 \times \text{PFA}) + 5$, in bar

The allowable pressures within a pipeline system shall be limited to the lowest pressure classification of all components within the system.

4.2.1.2 Preferred pressure classes

Preferred pressure classes of components with flexible joints are C25, C30, and C40. Other pressure classes are allowable, including C20, C50, C64 and C100.

Pressure classes for components with flanged joints are PN10, PN16, PN25 and PN40.

4.2.1.3 Allowable pressures

Allowable pressures of components are as given in Tables 1 and 2.

Table 1 — Allowable pressures of components with flexible joints for preferred classes

Pressure class	Allowable operating pressure	Maximum allowable operating pressure	Allowable site test pressure
C	PFA bar	PMA bar	PEA bar
25	25	30	35
30	30	36	41
40	40	48	53

Table 2 — Allowable pressures of components with flanged joints

Pressure class	Allowable operating pressure	Maximum allowable operating pressure	Allowable site test pressure
PN	PFA bar	PMA bar	PEA bar
10	10	12	17
16	16	20	25
25	25	30	35
40	40	48	53

The allowable pressure for fittings as specified in Tables 15 to 33 are as follows:

- socketed fittings, except tees, are given in Table 3;
- socketed tees may be less than those given in Table 3 and shall be given in the manufacturer's handbook;
- all flanged fittings and fittings with one flange, such as double-socketed tees with flanged branch, flanged spigots and flanged sockets, are limited by the flange PN and are given in Table 2.

Table 3 — Allowable pressures for socketed fittings

Nominal size DN	Allowable operating pressure PFA bar	Maximum allowable operating pressure PMA bar	Allowable site test pressure PEA bar
40 to 200	64	77	82
250 to 350	50	60	65
400 to 600	40	48	53
700 to 1400	30	36	41
1500 to 2600	25	30	35

Appropriate limitations shall be taken into account, which can prevent the full range of these pressures being used in an installed pipeline. For example, operation at the PFA values can be limited by the lower pressure capability of other pipeline components, e.g. flanged pipework, certain types of tees and specific designs of flexible joints. When other limitations exist due to the joint type or to any specific design arrangement, they shall be given in the manufacturer's handbook.

4.2.2 Diameter

4.2.2.1 External diameter

Table 14 gives the values of the external diameter, DE, of the spigot end of pipes and fittings, when measured circumferentially using a circumferential tape as specified in 6.1.1. The positive tolerance is + 1 mm and applies to all pressure classes of pipes and also to flanged spigot fittings.

The negative tolerance depends on the design of each type of joint and shall be as specified in national standards, or, when not so specified, in manufacturers' handbooks, for the type of joint and the nominal size considered.

In addition, the ovality (see 3.21) of the spigot end of pipes and fittings shall

- remain within the tolerances of DE for DN 40 to 200, and
- not exceed 1 % of DE for DN 250 to DN 600 or 2 % for DN > DN 600.

The manufacturer's recommendations should be followed with respect to the necessity and means of ovality correction; certain types of flexible joints can accept the maximum ovality without the need for spigot re-rounding prior to jointing.

4.2.2.2 Internal diameter

The nominal values of the internal diameters of centrifugally cast pipes, expressed in millimetres, are approximately equal to the numbers indicating their nominal sizes, DN.

4.2.3 Wall thickness

4.2.3.1 Pipes with flexible joints

The minimum wall thickness for pipes, e_{\min} , shall be not less than 3,0 mm and shall be determined using Equation (2):

$$e_{\min} = \frac{\text{PFA} \times \text{SF} \times \text{DE}}{20R_m + (\text{PFA} \times \text{SF})} \quad (2)$$

where

e_{\min} is the minimum pipe wall thickness, in millimetres;

PFA is the allowable operating pressure, in bar;

SF is the safety factor for PFA (= 3);

DE is the nominal pipe external diameter (see Table 14), in millimetres;

R_m is the minimum tensile strength of ductile iron, in megapascals ($R_m = 420$ MPa; see Table 8).

NOTE Equation (2) is derived from Barlow's equation, i.e. hoop stress, $\sigma = PD/2t$ (see 3.14)

For pipes centrifugally cast, the minimum wall thickness, e_{\min} , shall not be less than 3,0 mm. The nominal wall thickness, e_{nom} , is equal to the minimum wall thickness, e_{\min} , plus (1,3 + 0,001 DN).

For pipes not centrifugally cast, the minimum wall thickness, e_{\min} , shall not be less than 4,7 mm. The nominal wall thickness, e_{nom} , is equal to the minimum wall thickness, e_{\min} , plus (2,3 + 0,001 DN).

For centrifugally cast pipes, nominal pipe wall thicknesses for preferred ductile iron pressure classes are given in Table 14. For other pressure classes, as given in Annex C, the user should confirm the availability with the manufacturer.

4.2.3.2 Flanged pipes

Flanged pipe shall be classified by PN number. The pressure class of the barrel of the flanged pipes shall be equal to or greater than a value in bar equal to the PN of the flanges. The pressure class of the flanged pipe barrel to be used for fabricated flanged pipe shall be as indicated in 8.2 for welded-on flanges, screwed-on flanges and integrally cast flanges.

NOTE Pipe threads are regarded as loss of wall thickness.

4.2.3.3 Fittings

Nominal wall thicknesses, e_{nom} , are given for fittings in Tables 15 to 29, with allowable pressures given in 4.2.1.3. The minimum wall thickness, e_{\min} , for fittings is: $e_{\min} = e_{\text{nom}} - (2,3 + 0,001 \text{ DN})$.

Fittings with other pressure classifications are allowed. The manufacturer shall be responsible for the design of the fittings including the determination of wall thickness. The minimum wall thickness, e_{\min} , shall be not less than 3,0 mm.

The design shall be carried out by a calculation method, e.g. finite element analysis, or an experimental method, e.g. hydrostatic testing, using a safety factor of 3 against failure with respect to PFA.

4.2.4 Length

4.2.4.1 Socket and spigot pipes

Pipes shall be supplied to the lengths given in Table 4.

Table 4 — Standardized lengths of socket and spigot pipe

Dimensions in metres

DN	Standardized lengths, L_u ^a
40 and 50	3
60 to 600	4 or 5 or 5,5 or 6 or 9
700 and 800	4 or 5,5 or 6 or 7 or 9
900 to 2600	4 or 5 or 5,5 or 6 or 7 or 8,15 or 9
NOTE Not all the standardized lengths are available in all countries.	
^a See 3.28.	

The manufacturers' design lengths, L_u (see 3.28), shall be within a deviation (see 3.6) of ± 250 mm with respect to the lengths given in Table 4 and shall be given in their handbooks. The actual length, L_u , shall be measured according to 6.1.3 and shall not differ from the manufacturer's design length by more than the tolerance given in Table 7. Of the total number of socket and spigot pipes to be supplied in each diameter, the percentage of shorter pipes shall not exceed 10 %.

NOTE 1 Pipes cut for test purposes can be excluded from the 10 % limitation and treated as full-length pipes.

NOTE 2 When pipes are ordered on a meterage basis, the manufacturer can determine the required quantity of pipes to be supplied by the summation of the measured individual pipe laying lengths.

4.2.4.2 Flanged pipes

The lengths of flanged pipes shall be as given in Table 5. Other lengths are available by agreement between the manufacturer and the purchaser.

Table 5 — Standardized lengths of flanged pipe

Dimensions in metres

Type of pipe	DN	Standardized lengths, L^a
With cast-on flanges	40 to 2600	0,5 or 1 or 2 or 3 or 4
With screwed-on or welded-on flanges	40 to 500	2 or 3 or 4 or 5
	600 to 1000	2 or 3 or 4 or 5 or 6
	1100 to 2600	4 or 5 or 6 or 7
^a See 3.28.		

4.2.4.3 Fittings

Fittings shall be supplied in the lengths given in 8.3 and 8.4 except that, alternatively, socket fittings may be supplied in the lengths of the national standard of the country of manufacture.

NOTE Two series of dimensions are shown, series A and series B, which is generally limited to DN 450 maximum.

The permissible deviations (see 3.6) on the lengths of series A fittings shall be as given in Table 6.

Table 6 — Permissible deviations on length of fittings

Dimensions in millimetres

Type of fitting	DN	Deviation
Flanged sockets	40 to 1200	± 25
Flanged spigots Collars, tapers	1400 to 2600	± 35
Tees	40 to 1200	+ 50 – 25
	1400 to 2600	+ 75 – 35
Bends 90° (1/4)	40 to 2600	$\pm (15 + 0,03) \text{ DN}$
Bends 45° (1/8)	40 to 2600	$\pm (10 + 0,025) \text{ DN}$
Bends 22° 30' (1/16) and 11° 15' (1/32)	40 to 1200	$\pm (10 + 0,02) \text{ DN}$
	1400 to 2600	$\pm (10 + 0,025) \text{ DN}$

4.2.4.4 Tolerances on lengths

The tolerances on lengths shall be as given in Table 7.

Table 7 — Tolerances on length

Dimensions in millimetres

Type of casting	Tolerance
Socket and spigot pipes (full length or shortened)	–30 +70
Fittings for socketed joints	± 20
Pipes and fittings for flanged joints	$\pm 10^a$

^a By agreement between manufacturer and purchaser, smaller tolerances are possible, but not less than ± 3 mm for $\text{DN} \leq 600$ and ± 4 mm for $\text{DN} > 600$.

4.2.5 Straightness of pipes

Pipes shall be straight, with a maximum deviation of 0,125 % of their length.

The verification of this requirement is normally carried out by visual inspection, but in case of doubt or in dispute, the deviation shall be measured in accordance with 6.2.

4.3 Material characteristics

4.3.1 Tensile properties

Pipes, fittings and accessories made of ductile iron shall have the tensile properties given in Table 8.

During the manufacturing process the manufacturer shall carry out suitable tests to verify these tensile properties; these tests may be either

- a) a batch sampling system whereby samples are obtained from the pipe spigot or, for fittings, from samples cast separately or integrally with the casting concerned (test bars shall be machined from these samples and tensile tested according to 6.3), or
- b) a system of process control testing (e.g. non-destructive), by which a positive correlation can be demonstrated with the tensile properties specified in Table 8; testing verification procedures shall be based on the use of comparator samples having known and verifiable properties; this system of testing shall be supported by tensile testing in accordance with 6.3.

Table 8 — Tensile properties

Type of casting	Minimum tensile strength, R_m MPa	Minimum percent elongation after fracture, A %	
	DN 40 to DN 2600	DN 40 to DN 1000	DN 1100 to DN 2600
Pipes centrifugally cast	420	10	7
Pipes not centrifugally cast, fittings and accessories	420	5	5

By agreement between the manufacturer and the purchaser, the 0,2 % proof stress, $R_{p0.2}$, may be measured. It shall be not less than: 270 MPa when $A \geq 12$ % for DN 40 to DN 1000 or when $A \geq 10$ % for DN > 1000; 300 MPa in other cases. For centrifugally cast pipes of DN 40 to DN 1000 having a design minimum wall thickness of 10 mm or greater, the minimum elongation after fracture shall be 7 %.

4.3.2 Brinell hardness

The hardness of the various components shall be such that they can be cut, tapped, drilled and/or machined with standard tools. In case of dispute, the hardness shall be measured according to 6.4.

The Brinell hardness shall not exceed 230 HBW for centrifugally cast pipes and 250 HBW for non-centrifugally cast pipes, fittings and accessories. For components manufactured by welding, a higher Brinell hardness is allowed in the heat-affected zone of the weld.

4.4 Coating and linings for pipes

Pipes shall normally be delivered internally and externally coated.

4.4.1 External coatings

Ductile iron pipeline systems can be installed in a wide range of external operating environments. These environments can be characterized according to their aggressivity. For relevant factors, see A.1.

Coatings specified by relevant International Standards are available as specified in A.2. Other coatings are available.

4.4.2 Internal linings

Ductile iron pipeline systems can be used to convey a wide range of raw waters and potable waters. These internal environments can be characterized by their aggressivity. Relevant factors to be considered for cement mortar linings without seal coats are given in B.1.

Linings specified by relevant International Standards are available as specified in B.2. Other linings are also available.

4.5 Coatings and linings for fittings and accessories

Fittings and accessories shall normally be delivered internally and externally coated.

4.5.1 External coatings

Ductile iron pipeline systems can be installed in a wide range of external operating environments. These environments can be characterized by their aggressivity. For relevant factors, see A.1.

Coatings specified by relevant International Standards are available as specified in A.3. Other coatings are also available.

4.5.2 Internal linings

Ductile iron pipeline systems can be used to convey a wide range of raw waters and potable waters. These internal environments can be characterized according to their aggressivity. Relevant factors to be considered for cement mortar linings without seal coats are given in B.1.

Linings specified by relevant International Standards are available as specified in B.3. Other linings are also available.

4.6 Marking

All pipes and fittings shall be durably and legibly marked and shall bear at least the following indications:

- a) a reference to this International Standard, i.e. ISO 2531;
- b) the manufacturer's name or mark;
- c) identification of the year of manufacture;
- d) identification as ductile iron;
- e) the DN;
- f) the PN rating of flanges, if applicable;
- g) the C pressure class of socket and spigot pipe.

Items b) to f) shall be cast-on or cold stamped. Items a) and g) can be applied by any method, e.g. painted on the castings.

5 Leaktightness requirements

5.1 Pipes and fittings

Pipes and fittings shall be designed to be leaktight at their allowable site test pressure (PEA). They shall be tested according to 6.5 and shall exhibit no visible leakage, sweating or any other sign of failure.

5.2 Flexible joints

5.2.1 General

All flexible joints for ductile iron pipes and components shall be designed in compliance with the requirements of 5.2. If the design has been tested and documented by the manufacturer and successfully used for a minimum of 10 years, the performance of a type test as specified in 5.2.2 for internal pressure, as specified

in 5.2.3 for external pressure and as specified in 5.2.4 for negative internal pressure, is only required for significant changes in design which could adversely affect the performance of the joint.

Joint designs shall be type tested to demonstrate leaktightness to both internal and external pressure under the most unfavourable conditions of castings tolerances and joint movements.

There shall be a type test for at least one DN for each of the groupings given in Table 9. One DN is representative of a grouping when the performances are based on the same design parameters throughout the size range.

Table 9 — DN groupings for type tests

DN groupings	40 to 250	300 to 600	700 to 1000	1100 to 2000	2200 to 2600
Preferred DN in each grouping	200	400	800	1600	2400

If a grouping covers products of different designs and/or manufactured by different processes, the grouping shall be sub-divided.

If, for a manufacturer, a grouping contains only one DN or PN, this DN or PN may be considered as part of the adjacent grouping provided that it is of identical design and manufactured by the same process.

The type tests shall be carried out in the configuration of maximum design radial gap between the components to be jointed (smallest spigot together with largest socket).

In the type test, the maximum gap shall be equal to the maximum design radial gap with a tolerance of $-\frac{0}{5}$ %. The internal socket diameter may be machined to achieve this, even if the resulting diameter is slightly outside the normal manufacturing tolerance.

All joints shall be performance tested with a spigot having an average iron wall thickness (over a distance of 2 DN, in millimetres, from the spigot face) equal to the specified minimum value for the pipe for which the joint is designed, $+\frac{10}{0}$ %. It is permissible to machine the spigot of the pipe bore to achieve the required thickness.

Restrained flexible joints shall be designed and tested in accordance with ISO 10804.

5.2.2 Internal pressure

The leaktightness of joints to internal pressure shall be type tested as specified in 7.1 at a test pressure of 1,5PFA + 5 bar; the joints shall exhibit no visible leakage in the two following positions:

- a) joint aligned and subjected to shear; the shear force across the joint, expressed in N, shall not be less than 30 times DN;
- b) joint deflected; the test angular deflection shall be the maximum allowable deflection indicated in the manufacturer's handbook, but not less than 3° 30' for DN 40 to DN 300, 2° 30' for DN 350 to DN 600, 1° 30' for DN 700 to DN 2600. These minimum deflections do not apply to restrained joint pipe.

5.2.3 External pressure

The leaktightness of joints to external pressure shall be type tested as specified in 7.2; the joints shall exhibit no visible leakage when subjected to a shear load, expressed in newtons, not less than 30 times DN.

The test pressure shall be not less than 2 bar.

5.2.4 Negative internal pressure

The leaktightness of joints to negative internal pressure shall be type tested as specified in 7.3 at a test pressure of 0,9 bar below atmospheric pressure (approximately 0,1 bar absolute pressure). The maximum pressure change during the test period shall not be more than 0,09 bar after 2 h, when tested in the following two positions:

- a) joint aligned and subjected to shear; the shear force across the joint, expressed in N, shall not be less than 30 times DN;
- b) joint deflected; the test angular deflection shall be the maximum allowable deflection indicated in the manufacturer's handbook, but not less than 3° 30' for DN 40 to DN 300, 2° 30' for DN 350 to DN 600, 1° 30' for DN 700 to DN 2600. These minimum deflections do not apply to restrained joint pipe.

5.3 Flanged joints as cast, screwed, welded and adjustable

5.3.1 General

All flanged joints for ductile iron pipes and components shall be designed in compliance with the requirements of 5.3. If the design has been tested and documented by the manufacturer and successfully used for a minimum of 10 years, the performance of a type test as specified in 5.3.2 is only required for significant changes in design which could adversely affect the performance of the joint.

When flanges are involved, there shall be a type test for at least one DN for each of the groupings given in Table 9. The PN to be tested is the highest PN existing for each flange design. One PN is representative of a grouping when the performances are based on the same design parameters throughout the size range.

If a grouping covers products of different designs and/or manufactured by different processes, the grouping shall be sub-divided.

If, for a manufacturer, a grouping contains only one DN or PN, this DN or PN may be considered as part of the adjacent grouping provided that it is of identical design and manufactured by the same process.

5.3.2 Internal pressure and bending moment

In order to demonstrate their strength and leaktightness in service conditions, flanged joints shall be subjected to a type test. When tested as specified in 7.4, they shall show no visible leakage under the combined effects of a hydrostatic internal pressure and a bending moment as given in Table 10, where

- the pressure is $(1,5PN + 5)$ bar,
- the relevant bending moment is obtained by addition of the bending moments due to the weight of the components and of the water in the test assembly and those due to a possible external load calculated as a function of the length of the unsupported span of the testing arrangement (see 7.4).

A type test shall be carried out on each type of flange joint available from the manufacturer in accordance with Table 10.

The bending moments given in Table 10 are approximately equal to those resulting from the weight of the preferred classes of pipes (utilizing the nominal thicknesses), of the cement mortar lining, and of the water over an unsupported pipe length, L , between simple supports, with, for welded, integrally cast and adjustable flanged joints,

- $L = 8$ m for $DN \leq 250$,
- $L = 12$ m for $DN \geq 300$;

and for screwed flanged joints,

— $L = 6,8$ m for $DN \leq 800$,

— $L = 10$ m for $DN \geq 900$.

Table 10 — Bending moments for flange joint type tests of preferred classes of pipes

DN	Integrally cast, welded and adjustable	Screwed
	kN·m	kN·m
40	0,6	0,4
50	0,7	0,6
60	0,9	0,7
65	1,0	0,8
80	1,3	1,0
100	1,7	1,4
125	2,4	2,0
150	3,1	2,7
200	4,8	4,5
250	7,1	6,7
300	22,1	9,3
350	29,1	12,6
400	36	16
450	45	20
500	54	25
600	77	35
700	100	47
800	129	52
900	161	140
1000	197	159
1100	237	192
1200	281	214
1400	383	274
1500	437	314
1600	495	355
1800	623	447
2000	766	549
2200	928	644
2400	1 100	764
2600	1 287	894

6 Test methods

6.1 Dimensions

6.1.1 External diameter

Pipes with sockets and spigot ends shall be measured at their spigot by means of a circumferential tape for compliance with the outer diameter tolerance. They can also be verified by means of pass-fail gauges.

In addition, the pipes shall be visually inspected at their spigot for compliance with the ovality tolerance and, in case of doubt, checked by measurement of the maximum and minimum axes. This control may also be carried out by pass-fail gauges.

The frequency of testing is related to the system of production and the quality control used by the manufacturer.

6.1.2 Wall thickness

Pipe wall thickness compliance shall be demonstrated by the manufacturer; a combination of various means may be used, such as:

- pipe weight control;
- direct wall thickness measuring or gauging by suitable equipment, such as mechanical or ultrasonic equipment. The frequency of testing is related to the system of production and quality control used by the manufacturer.

6.1.3 Length

The length of centrifugally cast pipes with sockets and spigot ends shall be measured by means of suitable equipment

- on the first pipe cast from a new mold, for full length pipes, and
- on the first cut pipe, for pipes which are systematically cut to a predetermined length.

6.2 Straightness of pipes

The pipe shall be rolled on two supports or rotated along its axis on rollers, which in each case are separated by at least two thirds of the standard pipe length.

The point of maximum deviation from the true axis shall be determined, and the deviation measured at that point shall not exceed the limit fixed in 4.2.5.

6.3 Tensile test

6.3.1 Sampling

The thickness of the sample and the diameter of the test bar shall be as indicated in Table 11.

6.3.1.1 Centrifugally cast pipes

A sample shall be cut from the spigot of the pipe. This sample may be cut perpendicular to, or parallel with, the pipe axis, but in case of dispute the parallel-to-axis sample shall be used.

6.3.1.2 Pipes not cast centrifugally, fittings and accessories

Samples shall be taken, at the manufacturer’s discretion, either from an integrally cast sample, from a sample attached to the casting, or from a sample cast separately. In the latter case, it shall be cast from the same metal as that used for the casting. If the casting is subjected to heat treatment, the sample shall be subjected to the same heat treatment.

6.3.2 Test bar

A test bar shall be machined from each sample to be representative of the metal at the mid-thickness of the sample, with a cylindrical part having the diameters given in Table 11. If the specified diameter of the test bar is greater than 60 % of the measured minimum thickness of the sample, it is allowed to machine a test bar with a smaller diameter, or to cut another sample in a thicker part of the pipe. Other test bar shapes, complying with International Standards or national standards are permitted.

The test bars shall have a gauge length at least five times the nominal test bar diameter. The ends of the test bars shall be such that they will fit the testing machine.

The surface roughness of the machined gauge length of the test bar shall be such that $R_z \leq 6,3 \mu\text{m}$.

Two methods of measuring the tensile strength may be used at the manufacturer’s discretion:

Method A:

Produce the test bar to a nominal diameter $\pm 10 \%$, measure the actual diameter before the test with an accuracy of $\pm 0,01 \text{ mm}$ and use this measured diameter to calculate the cross-sectional area and the tensile strength; or

Method B:

Produce the test bar to a nominal area, S_0 , within a specified tolerance on the diameter (see Table 11) and use the nominal area to calculate the tensile strength.

Table 11 — Dimensions of test bar

Type of casting	Test bar method A	Test bar method B		
	Nominal diameter mm	Nominal area S_0 mm ²	Nominal diameter mm	Tolerance on diameter mm
Centrifugally cast pipes with wall thickness:				
— less than 6 mm	2,5	5	2,52	$\pm 0,01$
— 6 mm up to but not including 8 mm	3,5	10	3,57	$\pm 0,02$
— 8 mm up to but not including 12 mm	5	20	5,05	$\pm 0,02$
— 12 mm and over	6	30	6,18	$\pm 0,03$
Pipes, fittings and accessories not cast centrifugally:				
— integrally cast samples	5	20	5,05	$\pm 0,02$
— separately cast samples:	5	20	5,05	$\pm 0,02$
— thickness 12,5 mm for casting thickness less than 12 mm	6	30	6,18	$\pm 0,03$
— thickness 25 mm for casting thickness 12 mm and over	12 or 14	—	—	—

6.3.3 Equipment and test method

The tensile testing machine shall have suitable holders or grips to attach to the test bar ends so as to positively apply the test load axially. The testing machine shall have a force range suitable for testing the bars to failure whilst indicating the load applied.

The rate of stressing shall be as constant as possible within the limits of 6 N/mm² per second to 30 N/mm² per second.

The tensile strength shall be calculated by dividing the maximum force sustained by the test bar by the cross-sectional area of the test bar before testing. The elongation shall be measured by piecing together the broken parts of the test bar and taking the ratio of the extended gauge length to the original gauge length. Alternatively, the elongation may be measured directly by means of an extensometer.

6.3.4 Test results

Test results shall comply with Table 8. If they do not comply, the manufacturer shall:

- in the case where the metal does not achieve the required mechanical properties, investigate the reason and ensure that all castings in the batch are either re-heat-treated or rejected; castings which have been re-heat-treated are then re-tested as specified in 6.3;
- in the case of a defect in the test bar, carry out a further test. If it passes, the batch is accepted; if not, the manufacturer has the option to proceed in accordance with a) above.

NOTE The manufacturer can limit the amount of rejection by making additional tests, in order of manufacture, until the rejected batch of castings is bracketed by a successful test at each end of the interval in question.

6.3.5 Test frequency

The frequency of testing is related to the system of production and quality control used by the manufacturer (see 4.3.1). The maximum batch sizes shall be as given in Table 12.

Table 12 — Maximum batch sizes for tensile testing

Type of casting	DN	Maximum batch size	
		Batch sampling system	Process control testing system
Centrifugally cast pipes	40 to 300	200 pipes	1 200 pipes
	350 to 600	100 pipes	600 pipes
	700 to 1000	50 pipes	300 pipes
	1100 to 2600	25 pipes	150 pipes
Pipes not cast centrifugally, fittings and accessories	All sizes	4 t ^a	48 t ^a

^a Mass of crude castings, excluding risers.

6.4 Brinell hardness

When Brinell hardness tests are carried out (see 4.3.2), they shall be performed either on the casting in dispute or on a sample cut from the casting. The surface to be tested shall be suitably prepared by slight local grinding, and the test shall be carried out in accordance with ISO 6506-1, using a ball of 2,5 mm or 5 mm or 10 mm diameter.

6.5 Works leaktightness test of pipes and fittings

6.5.1 General

Pipes and fittings shall be tested as specified in 6.5.2 and 6.5.3, respectively. The test shall be carried out on all pipes and fittings before the application of their external and internal coatings, except for the metallic zinc coating of pipes which may be applied before the test.

The test apparatus shall be suitable for applying the specified test pressures to the pipes and/or fittings. It shall be equipped with an industrial pressure gauge with an error limit of $\pm 3\%$.

6.5.2 Centrifugally cast pipes

The internal hydrostatic pressure shall be raised until it reaches the works hydrostatic test pressure equal to the pressure class and limited to the pressure of Preferred Classes. Higher pressures are permissible. The total duration of the pressure cycle shall be not less than 15 s, including 10 s at test pressure. Visual inspection shall be made during or immediately after the pressure test.

6.5.3 Pipes not cast centrifugally and fittings

At the discretion of the manufacturer, these pipes and fittings shall be submitted to a hydrostatic pressure test or an air test.

When the hydrostatic pressure test is carried out, it shall be done in the same way as for centrifugally cast pipes (see 6.5.2), except for the test pressures, which shall be as given in Table 13.

Table 13 — Works test pressure for pipes not cast centrifugally and fittings

DN	Pipes not cast centrifugally and fittings bar ^a
40 to 300	25 ^b
350 to 600	16
700 to 2600	10

^a The works hydrostatic test pressure is less than for pipes because of the difficulty providing sufficient restraint to high internal pressure during testing.

^b 16 bar for pipes and fittings with PN 10 flanges.

When the air test is carried out, it shall be with an internal pressure of at least 1 bar and a visual inspection time of not less than 10 s; for leak detection, the castings shall be either uniformly coated on the external surface by a suitable foaming agent or submerged in water.

7 Type tests

7.1 Leaktightness of joints to internal pressure

This type test shall be carried out on an assembled joint comprising two pipe sections each at least 1 m long (see Figure 1).

The test apparatus shall be capable of providing suitable end restraints, whether the joint is in the aligned position, or deflected, or subjected to a shear load. It shall be equipped with a pressure gauge having an accuracy of $\pm 3\%$.

The shear load, W , shall be applied to the spigot by means of a V-shaped block with an angle of 120° , located at approximately $0,5 \times DN$, in millimetres, or 200 mm from the socket face (whichever is the greater); the

socket shall bear on a flat support. The load, W , shall be such that the resultant shear force, F , across the joint is equal to the value specified in 5.2.2, taking into account the mass, M , of the pipe and its contents and the geometry of the test assembly, as given in Equation (3):

$$W = \frac{F \times c - M (c - b)}{c - a} \quad (3)$$

where

F is the resultant shear force across the joint, expressed in newtons;

M is the mass of the pipe and its contents, expressed in newtons;

W is the shear load, expressed in newtons;

a , b and c are given in Figure 1.

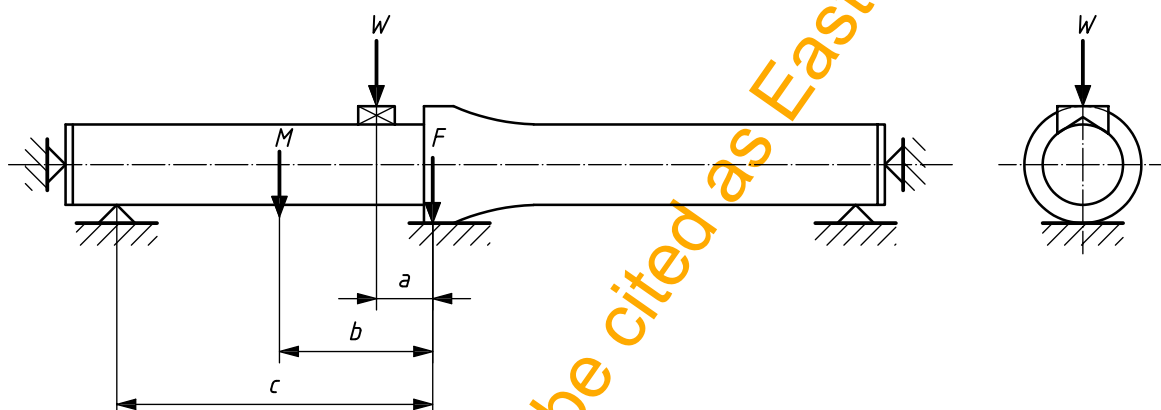

Figure 1 — Leaktightness of joints (internal pressure)

The test assembly shall be filled with water and suitably vented of air. The pressure shall be raised steadily until it reaches the test pressure given in 5.2.2; the rate of pressure increase shall not exceed 1 bar/s. The test pressure shall be kept constant within $\pm 0,5$ bar for at least 2 h, during which the joint shall be thoroughly inspected every 15 min.

7.2 Leaktightness of joints to external pressure

This type test assembly, which applies only to push-in flexible joints, shall comprise two joints made with two pipe sockets connected together and one double-spigot piece so as to create an annular chamber allowing to test one joint under internal pressure and one joint under external pressure (see Figure 2).

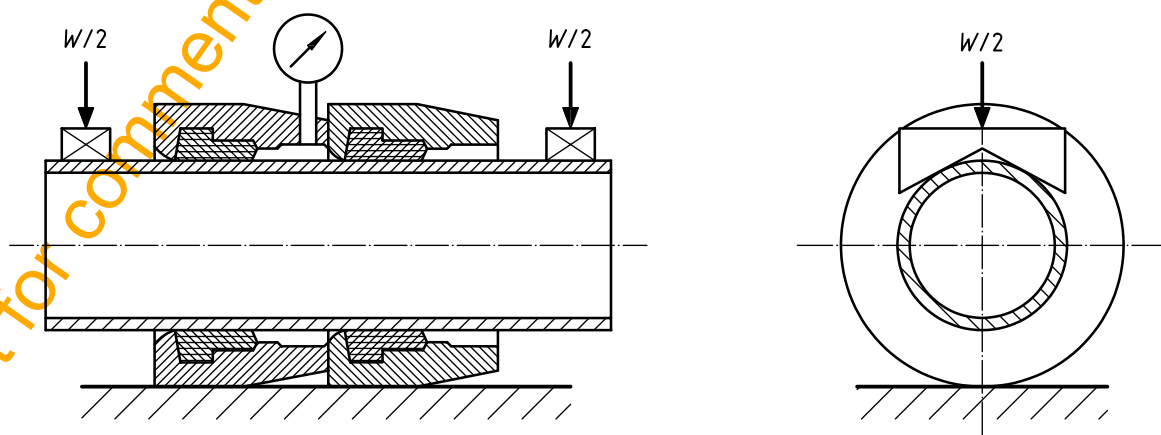

Figure 2 — Leaktightness of joints (external pressure)

The test assembly shall be subjected to the shear load defined in 5.2.3; one half of this load shall be applied to the spigot on each side of the test assembly, by means of a V-shaped block with an angle of 120°, located at approximately $0,5 \times DN$, in millimetres, or 200 mm from the end of sockets (whichever is the greater); the sockets shall bear on a flat support.

The test assembly shall then be filled with water and suitably vented of air. The pressure shall be steadily increased until it reaches the test pressure given in 5.2.3 and then kept constant within $\pm 0,1$ bar for at least 2 h, during which the internal side of the joint subjected to external pressure shall be thoroughly inspected every 15 min.

7.3 Leaktightness of joints to negative internal pressure

The test assembly and test apparatus shall be as given in 7.1 with the pipe sections axially restrained to prevent them moving towards each other.

The test assembly shall be empty of water and shall be evacuated to a negative internal pressure of 0,9 bar (see 5.2.4) and then isolated from the vacuum pump. The test assembly shall be left under vacuum for at least 2 h during which the pressure shall not have changed by more than 0,09 bar. The test shall begin at a temperature between 5 °C and 40 °C. The temperature of the test assembly shall not vary by more than 10 °C for the duration of the test.

7.4 Leaktightness and mechanical resistance of flanged joints

The test assembly shall comprise pipes and/or fittings with identical flanges, assembled together by means of the gasket and bolts defined by the manufacturer. Both ends of the test assembly shall be equipped with blank flanges. The bolts shall be tightened to the torque defined by the manufacturer for the maximum PN of the DN under test. The bolt material grade, when not defined, shall comply as a minimum to property class 4.6 of ISO 4016.

The test assembly shall be placed on two simple supports (see Figure 3) such that the assembled flanged joint is positioned at mid span. The minimum length of unsupported span shall be either 6 DN, in millimetres, or 4 000 mm, whichever is the smaller. This length can be obtained by a combination of pipes or fittings, but only the tested joint at mid span shall be considered.

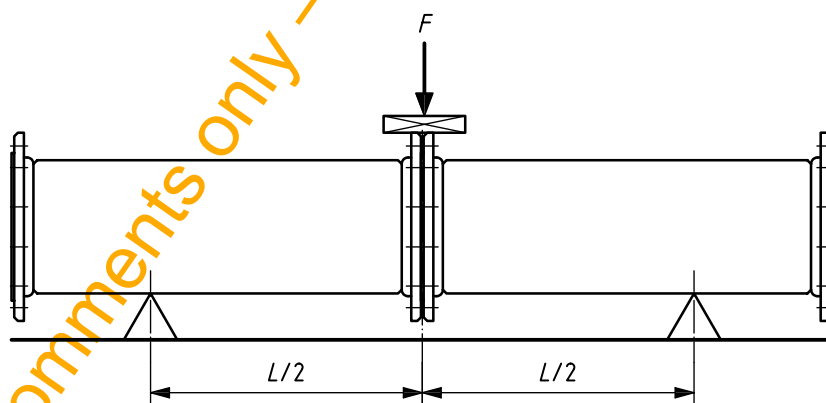

Figure 3 — Strength and leaktightness test for flanged joints

The test assembly shall be filled with water and suitably vented of air. The pressure shall be raised steadily until it reaches the test pressure given in 5.3. The external load, F , shall be applied to the assembled flanged joint by means of a flat plate, in a direction perpendicular to the axis of the test assembly, so as to cause the bending moment given in Table 10.

The internal pressure and the external load shall be kept constant for 2 h during which the flanged joint shall be thoroughly inspected.

CAUTION — All necessary safety precautions should be taken for the duration of the pressure test.

8 Tables of dimensions

8.1 Socket and spigot pipes

The dimensions of preferred pressure classes of socket and spigot pipes are as given in Figure 4 and Table 14. Wall thicknesses for preferred and other pressure classes of pipe are given in Annex C.

The values of L_u are given in Table 4. For external and internal coatings, see 4.4.

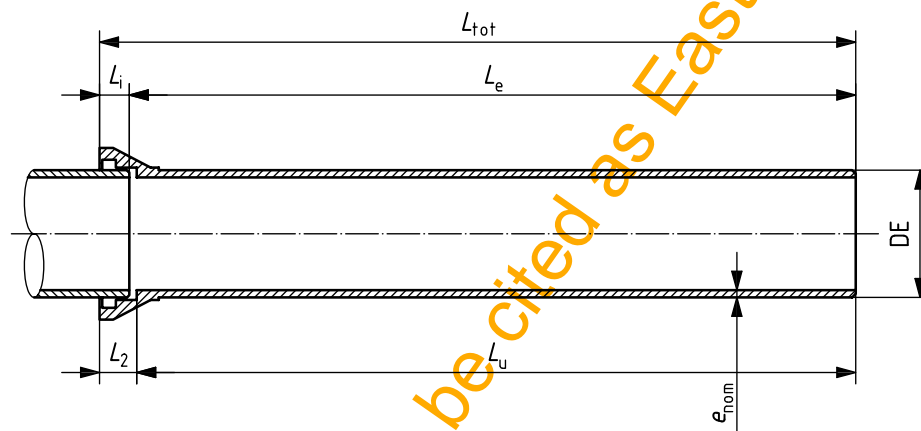

Key

DE	nominal external diameter of spigot, in millimetres
e_{nom}	nominal wall thickness, in millimetres
L_2	depth of socket, in metres
$L_e = L_{tot} - L_i$	laying length, in metres
L_i	maximum insertion depth as given by the manufacturer, in metres
L_{tot}	total length, in metres
$L_u = L_{tot} - L_2$	standardized length, in metres

Figure 4 — Socket and spigot pipes

Table 14 — Preferred pipe pressure classes

DN mm	DE ^a mm	Pressure class	Nominal iron wall thickness e_{nom} mm
40	56	C40	4,4
50	66	C40	4,4
60	77	C40	4,4
65	82	C40	4,4
80	98	C40	4,4
100	118	C40	4,4
125	144	C40	4,5
150	170	C40	4,5
200	222	C40	4,7
250	274	C40	5,5
300	326	C40	6,2
350	378	C30	6,3 ^b
400	429	C30	6,5 ^b
450	480	C30	6,9
500	532	C30	7,5
600	635	C30	8,7
700	738	C25	8,8 ^b
800	842	C25	9,6
900	945	C25	10,6
1000	1048	C25	11,6
1100	1152	C25	12,6
1200	1255	C25	13,6
1400	1462	C25	15,7
1500	1565	C25	16,7
1600	1668	C25	17,7
1800	1875	C25	19,7
2000	2082	C25	21,8
2200	2288	C25	23,8
2400	2495	C25	25,8
2600	2702	C25	27,9

^a A tolerance of +1 mm applies (see 4.2.2.1).

^b Thicknesses are greater than calculated for "smoothing" between C40 and C30 and also between C30 and C25.

8.2 Flanged pipes

A fundamental requirement for flanged pipework is its ability to support an external bending moment. The magnitude of these permissible bending moments is related to the weight of the pipe and its contents for a given span. Consequently, the manufacturer shall demonstrate by performance testing, as detailed in Clauses 5 and 7, the minimum thickness of pipe required for the different PN-rated flanges.

The values of L are given in Table 5.

For coatings and linings, see 4.4.

Dimensions of flanges are in conformity with ISO 7005-2 and EN 1092-2 (see 4.1.3.2).

8.3 Fittings for socketed joints

In Tables 15 to 23, all the dimensions are nominal values and are given in millimetres. The values of L_u and l_u have been rounded up to the nearest multiple of five.

For coating and linings, see 4.5.

8.3.1 Flanged sockets

See Figure 5 and Table 15.

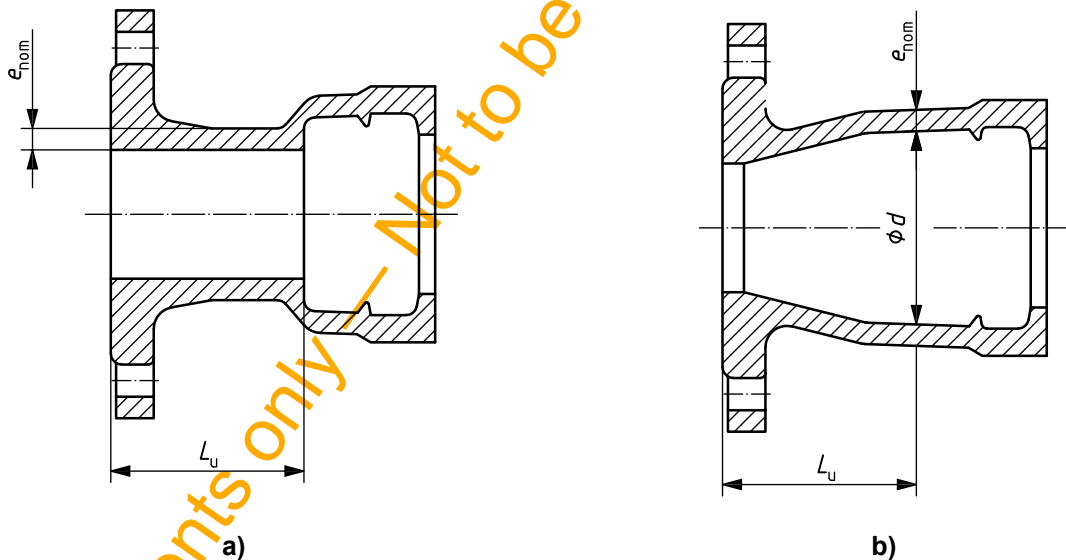

Figure 5 — Flanged socket

Table 15 — Dimensions of flanged sockets

DN	e_{nom}	L_{U}		d
		Series A	Series B	
40	7	125	75	67
50	7	125	85	78
60	7	125	100	88
65	7	125	105	93
80	7	130	105	109
100	7,2	130	110	130
125	7,5	135	115	156
150	7,8	135	120	183
200	8,4	140	120	235
250	9	145	125	288
300	9,6	150	130	340
350	10,2	155	135	393
400	10,8	160	140	445
450	11,4	165	145	498
500	12	170	—	550
600	13,2	180	—	655
700	14,4	190	—	760
800	15,6	200	—	865
900	16,8	210	—	970
1000	18	220	—	1 075
1100	19,2	230	—	1 180
1200	20,4	240	—	1 285
1400	22,8	310	—	1 477
1500	24	330	—	1 580
1600	25,2	330	—	1 683
1800	27,6	350	—	1 889
2000	30	370	—	2 095
2200	32,4	390	—	2 301
2400	34,8	410	—	2 507
2600	37,2	480	—	2 713

8.3.2 Flanged spigots

See Figure 6 and Table 16.

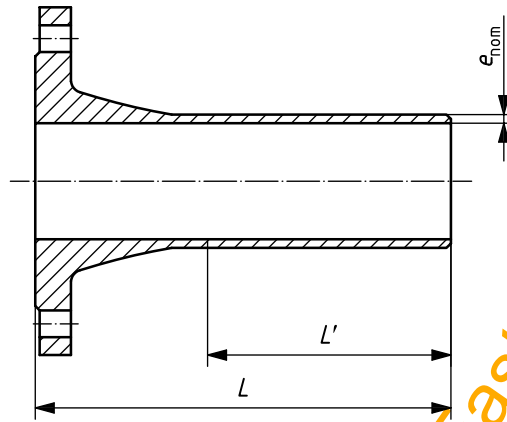

Figure 6 — Flanged spigot

8.3.3 Collars

See Figure 7 and Table 16.

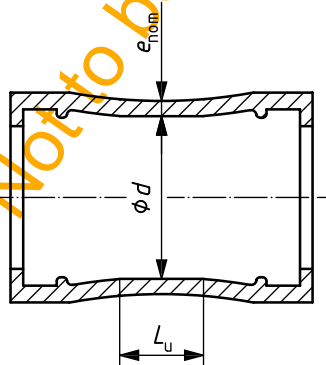

Figure 7 — Collar

Table 16 — Dimensions of flanged spigots and collars

DN	e_{nom}	Flanged spigots			Collars		
		L		L'	L_U		d
		Series A	Series B		Series A	Series B	
40	7	335	335	200	155	155	67
50	7	340	340	200	155	155	78
60	7	345	345	200	155	155	88
65	7	345	345	200	155	155	93
80	7	350	350	215	160	160	109
100	7,2	360	360	215	160	160	130
125	7,5	370	370	220	165	165	156
150	7,8	380	380	225	165	165	183
200	8,4	400	400	230	170	170	235
250	9	420	420	240	175	175	288
300	9,6	440	440	250	180	180	340
350	10,2	460	460	260	185	185	393
400	10,8	480	480	270	190	190	445
450	11,4	500	500	280	195	195	498
500	12	520	—	290	200	—	550
600	13,2	560	—	310	210	—	655
700	14,4	600	—	330	220	—	760
800	15,6	600	—	330	230	—	865
900	16,8	600	—	330	240	—	970
1000	18	600	—	330	250	—	1 075
1100	19,2	600	—	330	260	—	1 180
1200	20,4	600	—	330	270	—	1 285
1400	22,8	710	—	390	340	—	1 477
1500	24	750	—	410	350	—	1 580
1600	25,2	780	—	430	360	—	1 683
1800	27,6	850	—	470	380	—	1 889
2000	30	920	—	500	400	—	2 095
2200	32,4	990	—	540	420	—	2 301
2400	34,8	1 060	—	570	440	—	2 507
2600	37,2	1 130	—	610	460	—	2 713

NOTE The length L' is the length of the spigot to which the value of DE and its tolerance, as given in Table 14, apply.

8.3.4 Double-socket 90° (1/4) bends

See Figure 8 and Table 17.

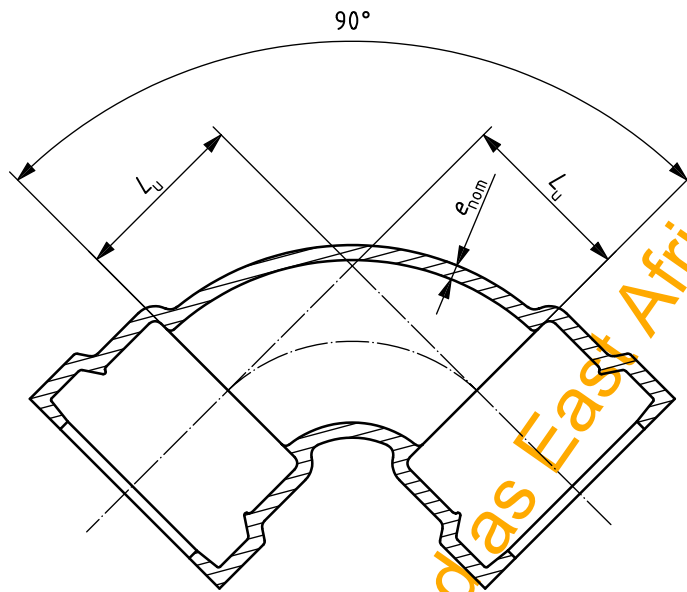

Figure 8 — Double-socket 90° bend

8.3.5 Double-socket 45° (1/8) bends

See Figure 9 and Table 17.

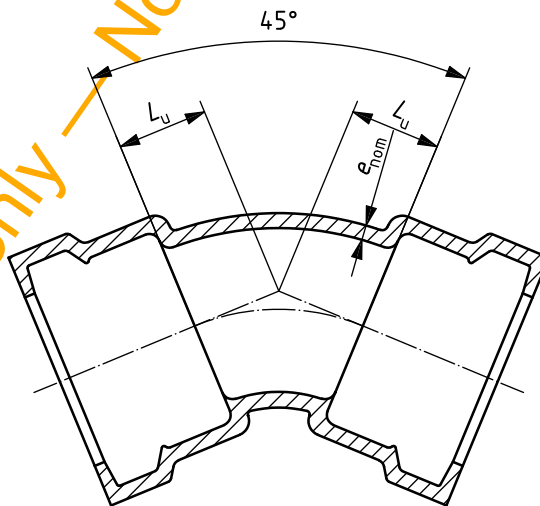

Figure 9 — Double-socket 45° bend

Table 17 — Dimensions of double-socket 90° and 45° bends

DN	e_{nom}	90° (1/4) bends		45° (1/8) bends	
		L_{U}		L_{U}	
		Series A	Series B	Series A	Series B
40	7	60	85	40	85
50	7	70	85	40	85
60	7	80	90	45	90
65	7	85	90	50	90
80	7	100	85	55	50
100	7,2	120	100	65	60
125	7,5	145	115	75	65
150	7,8	170	130	85	70
200	8,4	220	160	110	80
250	9	270	240	130	135
300	9,6	320	280	150	155
350	10,2	—	—	175	170
400	10,8	—	—	195	185
450	11,4	—	—	220	200
500	12	—	—	240	—
600	13,2	—	—	285	—
700	14,4	—	—	330	—
800	15,6	—	—	370	—
900	16,8	—	—	415	—
1000	18	—	—	460	—
1100	19,2	—	—	505	—
1200	20,4	—	—	550	—
1400	22,8	—	—	515	—
1500	24	—	—	540	—
1600	25,2	—	—	565	—
1800	27,6	—	—	610	—
2000	30	—	—	660	—
2200	32,4	—	—	710	—
2400	34,8	—	—	755	—
2600	37,2	—	—	805	—

8.3.6 Double-socket 22° 30' (1/16) bends

See Figure 10 and Table 18.

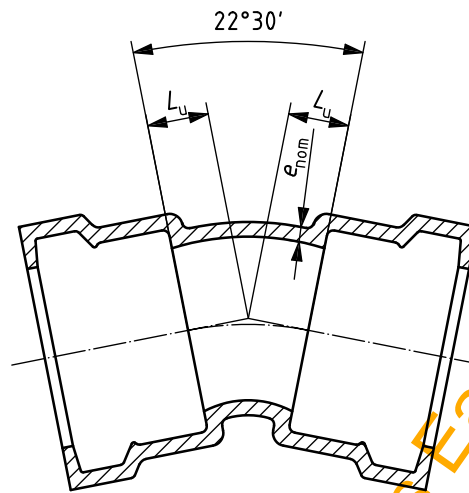

Figure 10 — Double-socket 22° 30' bend

8.3.7 Double-socket 11° 15' (1/32) bends

See Figure 11 and Table 18.

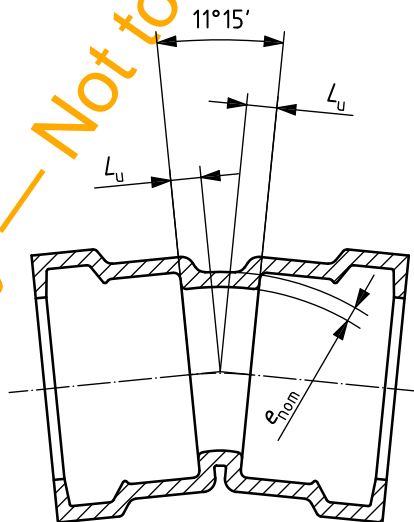

Figure 11 — Double-socket 11° 15' bend

Table 18 — Dimensions of double-socket 22° 30' and 11° 15' bends

DN	e_{nom}	22° 30' (1/16) bends		11° 15' (1/32) bends	
		L_U		L_U	
		Series A	Series B	Series A	Series B
40	7	30	30	25	25
50	7	30	30	25	25
60	7	35	35	25	25
65	7	35	35	25	25
80	7	40	40	30	30
100	7,2	40	50	30	30
125	7,5	50	55	35	35
150	7,8	55	60	35	40
200	8,4	65	70	40	45
250	9	75	80	50	55
300	9,6	85	90	55	55
350	10,2	95	100	60	60
400	10,8	110	110	65	65
450	11,4	120	120	70	70
500	12	130	—	75	—
600	13,2	150	—	85	—
700	14,4	175	—	95	—
800	15,6	195	—	110	—
900	16,8	220	—	120	—
1000	18	240	—	130	—
1100	19,2	260	—	140	—
1200	20,4	285	—	150	—
1400	22,8	260	—	130	—
1500	24	270	—	140	—
1600	25,2	280	—	140	—
1800	27,6	305	—	155	—
2000	30	330	—	165	—
2200	32,4	355	—	190	—
2400	34,8	380	—	205	—
2600	37,2	400	—	215	—

8.3.8 All socket tees

See Figure 12 and Table 19.

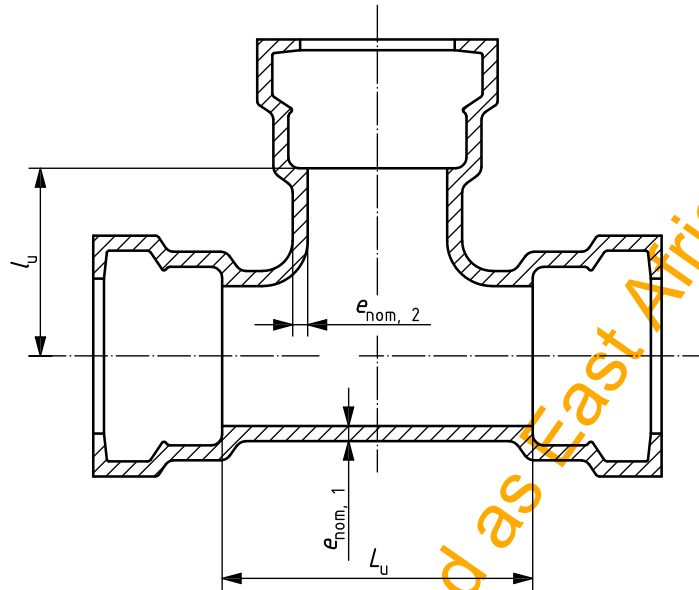

Figure 12 — All socket tee

Table 19 — Dimensions of all socket tees

DN × dn	Body			Branch		
	$e_{nom, 1}$	L_U		$e_{nom, 2}$	l_U	
		Series A	Series B		Series A	Series B
40 × 40	7	120	155	7	60	75
50 × 50	7	130	155	7	65	75
60 × 60	7	145	155	7	70	80
65 × 65	7	150	155	7	75	80
80 × 40	7	120	155	7	80	80
80 × 80	7	170	175	7	85	85
100 × 40	7,2	120	155	7	90	90
100 × 60	7,2	145	155	7	90	90
100 × 80	7,2	170	165	7	95	90
100 × 100	7,2	190	195	7,2	95	100
125 × 40	7,5	125	155	7	100	105
125 × 80	7,5	170	175	7	105	105
125 × 100	7,5	195	195	7,2	110	115
125 × 125	7,5	225	225	7,5	110	115
150 × 40	7,8	125	160	7	115	115
150 × 80	7,8	170	180	7	120	120
150 × 100	7,8	195	200	7,2	120	125
150 × 150	7,8	255	260	7,8	125	130
200 × 40	8,4	130	165	7	140	140
200 × 80	8,4	175	180	7	145	145
200 × 100	8,4	200	200	7,2	145	150
200 × 150	8,4	255	260	7,8	150	155
200 × 200	8,4	315	320	8,4	155	160
250 × 80	9	180	185	7	170	185
250 × 100	9	200	205	7,2	170	190
250 × 150	9	260	265	7,8	175	190
250 × 200	9	315	320	8,4	180	190
250 × 250	9	375	380	9	190	190
300 × 100	9,6	205	210	7,2	195	220
300 × 150	9,6	260	265	7,8	200	220
300 × 200	9,6	320	325	8,4	205	220
300 × 250	9,6	375	380	9	210	220
300 × 300	9,6	435	440	9,6	220	220

NOTE The main nominal size is designated DN and the nominal size of the branch is designated dn.

8.3.9 Double-socket tees with flanged branch, DN 40 to DN 250

See Figure 13 and Table 20.

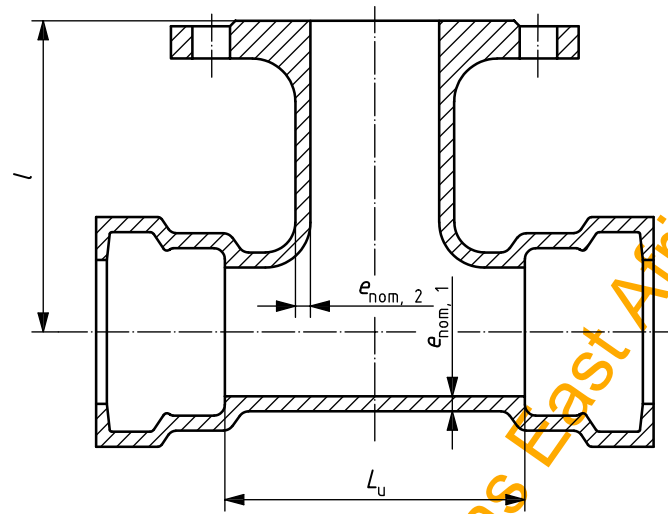

Figure 13 — Double-socket tee with flanged branch

Draft for comments only — Not to be cited as East African Standard

Table 20 — Dimensions of double-socket tees with flanged branch, DN 40 to DN 250

DN × dn	Body			Branch		
	$e_{nom, 1}$	L_u		$e_{nom, 2}$	l	
		Series A	Series B		Series A	Series B
40 × 40	7	120	155	7	130	130
50 × 50	7	130	155	7	140	140
60 × 40	7	—	155	7	—	130
60 × 60	7	145	155	7	150	150
65 × 40	7	—	155	7	—	130
65 × 65	7	150	155	7	150	155
80 × 40	7	—	155	7	—	135
80 × 60	7	—	155	7	—	155
80 × 80	7	170	175	7	165	165
100 × 40	7,2	—	155	7	—	145
100 × 60	7,2	—	155	7	—	165
100 × 80	7,2	170	165	7	175	170
100 × 100	7,2	190	195	7,2	180	180
125 × 40	7,5	—	155	7	—	160
125 × 60	7,5	—	155	7	—	180
125 × 80	7,5	170	175	7	190	185
125 × 100	7,5	195	195	7,2	195	195
125 × 125	7,5	225	225	7,5	200	200
150 × 40	7,8	—	160	7	—	170
150 × 60	7,8	—	160	7	—	190
150 × 80	7,8	170	180	7	205	200
150 × 100	7,8	195	200	7,2	210	205
150 × 125	7,8	—	230	7,5	—	215
150 × 150	7,8	255	260	7,8	220	220
200 × 40	8,4	—	165	7	—	195
200 × 60	8,4	—	165	7	—	215
200 × 80	8,4	175	180	7	235	225
200 × 100	8,4	200	200	7,2	240	230
200 × 125	8,4	—	235	7,5	—	240
200 × 150	8,4	255	260	7,8	250	245
200 × 200	8,4	315	320	8,4	260	260
250 × 60	9	—	165	7	—	260
250 × 80	9	180	185	7	265	265
250 × 100	9	200	205	7,2	270	270
250 × 150	9	260	265	7,8	280	280
250 × 200	9	315	320	8,4	290	290
250 × 250	9	375	380	9	300	300

NOTE The main nominal size is designated DN and the nominal size of the branch is designated dn.

8.3.10 Double-socket tees with flanged branch, DN 300 to DN 700

See Figure 13 and Table 21.

Table 21 — Dimensions of double-socket tees with flanged branch, DN 300 to DN 700

DN × dn	Body			Branch		
	$e_{\text{nom}, 1}$	L_u		$e_{\text{nom}, 2}$	l	
		Series A	Series B		Series A	Series B
300 × 60	9,6	—	165	7	—	290
300 × 80	9,6	180	185	7	295	295
300 × 100	9,6	205	210	7,2	300	300
300 × 150	9,6	260	265	7,8	310	310
300 × 200	9,6	320	325	8,4	320	320
300 × 250	9,6	—	380	9	—	330
300 × 300	9,6	435	440	9,6	340	340
350 × 60	10,2	—	170	7	—	320
350 × 80	10,2	—	185	7	—	325
350 × 100	10,2	205	210	7,2	330	330
350 × 150	10,2	—	270	7,8	—	340
350 × 200	10,2	325	325	8,4	350	350
350 × 250	10,2	—	385	9	—	360
350 × 350	10,2	495	500	10,2	380	380
400 × 80	10,8	185	190	7	355	355
400 × 100	10,8	210	210	7,2	360	360
400 × 150	10,8	270	270	7,8	370	370
400 × 200	10,8	325	330	8,4	380	380
400 × 250	10,8	—	385	9	—	390
400 × 300	10,8	440	445	9,6	400	400
400 × 400	10,8	560	560	10,8	420	420
450 × 100	11,4	215	215	7,2	390	390
450 × 150	11,4	270	270	7,8	400	400
450 × 200	11,4	330	330	8,4	410	410
450 × 250	11,4	390	390	9	420	420
450 × 300	11,4	445	445	9,6	430	430
450 × 400	11,4	560	560	10,8	450	450
450 × 450	11,4	620	620	11,4	460	460
500 × 100	12	215	—	7,2	420	—
500 × 200	12	330	—	8,4	440	—
500 × 400	12	565	—	10,8	480	—
500 × 500	12	680	—	12	500	—
600 × 200	13,2	340	—	8,4	500	—
600 × 400	13,2	570	—	10,8	540	—
600 × 600	13,2	800	—	13,2	580	—
700 × 200	14,4	345	—	8,4	525	—
700 × 400	14,4	575	—	10,8	555	—
700 × 700	14,4	925	—	14,4	600	—

NOTE The main nominal size is designated DN and the nominal size of the branch is designated dn.

8.3.11 Double-socket tees with flanged branch, DN 800 to DN 2600

See Figure 13 and Table 22.

Table 22 — Dimensions of double-socket tees with flanged branch, DN 800 to DN 2600

DN × dn	Body		Branch	
	$e_{nom, 1}$	L_u	$e_{nom, 2}$	l
		Series A		Series B
800 × 200	15,6	350	8,4	585
800 × 400	15,6	580	10,8	615
800 × 600	15,6	1 045	13,2	645
800 × 800	15,6	1 045	15,6	675
900 × 200	16,8	355	8,4	645
900 × 400	16,8	590	10,8	675
900 × 600	16,8	1 170	13,2	705
900 × 900	16,8	1 170	16,8	750
1000 × 200	18	360	8,4	705
1000 × 400	18	595	10,8	735
1000 × 600	18	1290	13,2	765
1000 × 1000	18	1290	18	825
1100 × 400	19,2	600	10,8	795
1100 × 600	19,2	830	13,2	825
1200 × 600	20,4	840	13,2	885
1200 × 800	20,4	1 070	15,6	915
1200 × 1000	20,4	1 300	18	945
1400 × 600	22,8	1 030	13,2	980
1400 × 800	22,8	1 260	15,6	1 010
1400 × 1000	22,8	1 495	18	1 040
1500 × 600	24	1 035	13,2	1 035
1500 × 1000	24	1 500	18	1 595
1600 × 600	25,2	1 040	13,2	1 090
1600 × 800	25,2	1 275	15,6	1 120
1600 × 1000	25,2	1 505	18	1 150
1600 × 1200	25,2	1 740	20,4	1 180
1800 × 600	27,6	1 055	13,2	1 200
1800 × 800	27,6	1 285	15,6	1 230
1800 × 1000	27,6	1 520	18	1 260
1800 × 1200	27,6	1 750	20,4	1 290
2000 × 600	30	1 065	13,2	1 310
2000 × 1000	30	1 530	18	1 370
2000 × 1400	30	1 995	22,8	1 430
2200 × 600	32,4	1 080	13,2	1 420
2200 × 1200	32,4	1 775	20,4	1 510
2200 × 1800	32,4	2 470	27,6	1 600
2400 × 600	34,8	1 090	13,2	1 530
2400 × 1200	34,8	1 785	20,4	1 620
2400 × 1800	34,8	2 480	27,6	1 710
2600 × 600	37,2	1 100	13,2	1 640
2600 × 1400	37,2	2 030	22,8	1 750
2600 × 2000	37,2	2 725	30	1 850

NOTE The main nominal size is designated DN and the nominal size of the branch is designated dn.

8.3.12 Double-socket tapers

See Figure 14 and Table 23.

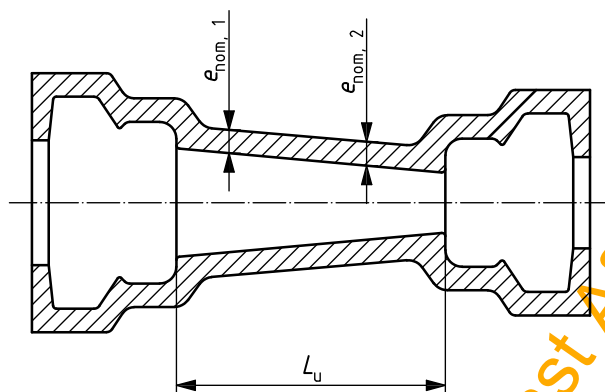

Figure 14 — Double-socket taper

Table 23 — Dimensions of double-socket tapers

DN × dn	$e_{nom, 1}$	$e_{nom, 2}$	L_u	
			Series A	Series B
50 × 40	7	7	70	75
60 × 50	7	7	70	75
65 × 50	7	7	80	75
80 × 40	7	7	—	80
80 × 60	7	7	90	80
80 × 65	7	7	80	80
100 × 60	7,2	7	—	120
100 × 80	7,2	7	90	85
125 × 60	7,5	7	—	190
125 × 80	7,5	7	140	135
125 × 100	7,5	7,2	100	120
150 × 80	7,8	7	190	190
150 × 100	7,8	7,2	150	150
150 × 125	7,8	7,5	100	115
200 × 100	8,4	7,2	250	250
200 × 125	8,4	7,5	200	230
200 × 150	8,4	7,8	150	145

Table 23 (continued)

DN × dn	$e_{\text{nom}, 1}$	$e_{\text{nom}, 2}$	L_u	
			Series A	Series B
250 × 125	9	7,5	300	335
250 × 150	9	7,8	250	250
250 × 200	9	8,4	150	150
300 × 150	9,6	7,8	350	370
300 × 200	9,6	8,4	250	250
300 × 250	9,6	9	150	150
350 × 200	10,2	8,4	360	370
350 × 250	10,2	9	260	260
350 × 300	10,2	9,6	160	160
400 × 250	10,8	9	360	380
400 × 300	10,8	9,6	260	260
400 × 350	10,8	10,2	160	155
450 × 350	11,4	10,2	260	270
450 × 400	11,4	10,8	160	160
500 × 350	12	10,2	360	—
500 × 400	12	10,8	260	—
600 × 400	13,2	10,8	460	—
600 × 500	13,2	12	260	—
700 × 500	14,4	12	480	—
700 × 600	14,4	13,2	280	—
800 × 600	15,6	13,2	480	—
800 × 700	15,6	14,4	280	—
900 × 700	16,8	14,4	480	—
900 × 800	16,8	15,6	280	—
1000 × 800	18	15,6	480	—
1000 × 900	18	16,8	280	—
1100 × 1000	19,2	18	280	—
1200 × 1000	20,4	18	480	—
1400 × 1200	22,8	20,4	360	—
1500 × 1400	24	22,8	260	—
1600 × 1400	25,2	22,8	360	—
1800 × 1600	27,6	25,2	360	—
2000 × 1800	30	27,6	360	—
2200 × 2000	32,4	30	360	—
2400 × 2200	34,8	32,4	360	—
2600 × 2400	37,2	34,8	360	—

NOTE The larger nominal size is designated DN and the smaller nominal size is dn.

8.4 Fittings for flanged joints

In Tables 24 to 33, all the dimensions are nominal values and are given in millimetres.

For coatings and linings, see 4.5.

8.4.1 Double-flanged 90° (1/4) bends

See Figure 15 and Table 24.

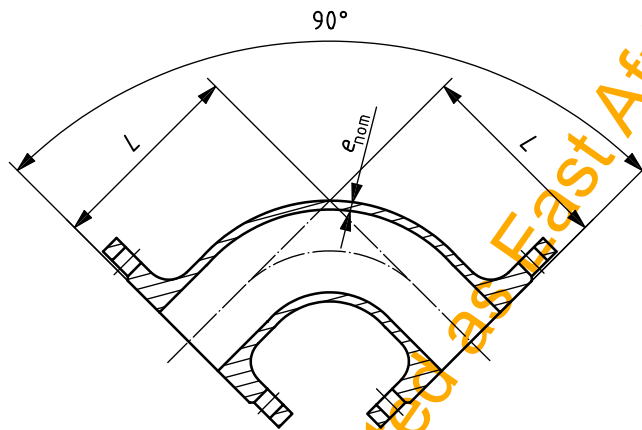

Figure 15 — Double-flanged 90° bend

8.4.2 Double-flanged duckfoot 90° (1/4) bends

See Figure 16 and Table 24.

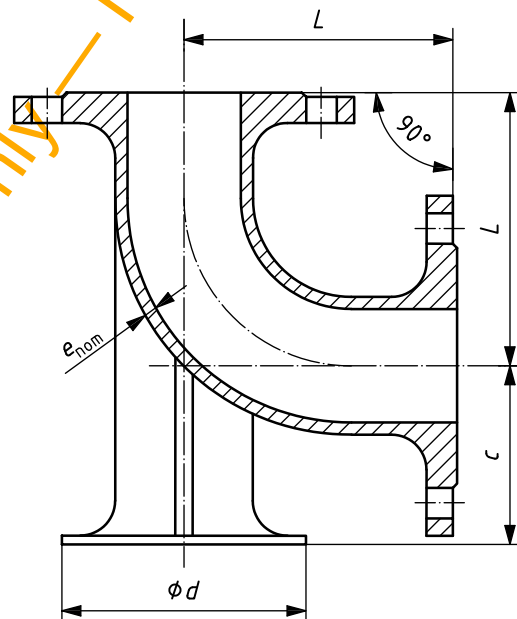

Figure 16 — Double-flanged duckfoot 90° bend

Table 24 — Dimensions of double-flanged 90° duckfoot bends

DN	A and B series				
	e_{nom}	90° (1/4) bends	90° (1/4) duckfoot bends		
		L	L	c	d
40	7	140	—	—	—
50	7	150	150	95	150
60	7	160	160	100	160
65	7	165	165	100	165
80	7	165	165	110	180
100	7,2	180	180	125	200
125	7,5	200	200	140	225
150	7,8	220	220	160	250
200	8,4	260	260	190	300
250	9	350	350	225	350
300	9,6	400	400	255	400
350	10,2	450	450	290	450
400	10,8	500	500	320	500
450	11,4	550	550	355	550
500	12	600	600	385	600
600	13,2	700	700	450	700
700	14,4	800	—	—	—
800	15,6	900	—	—	—
900	16,8	1 000	—	—	—
1000	18	1 100	—	—	—

8.4.3 Double-flanged 45° (1/8) bends

See Figure 17 and Table 25.

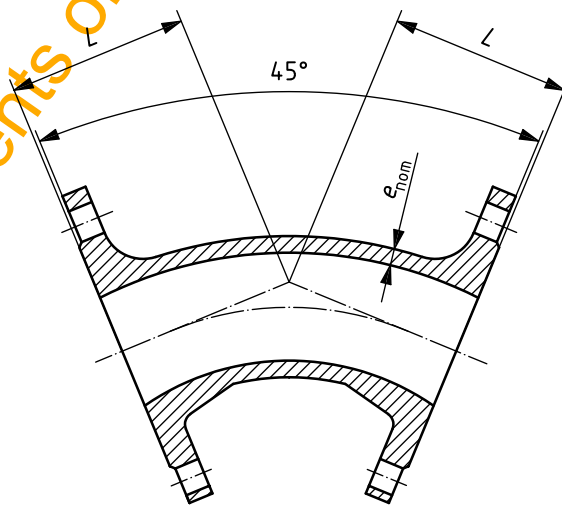

Figure 17 — Double-flanged 45° bend

Table 25 — Dimensions of double-flanged 45° (1/8) bends

DN	e_{nom}	L	
		Series A	Series B
40	7	140	140
50	7	150	150
60	7	160	160
65	7	165	165
80	7	130	130
100	7,2	140	140
125	7,5	150	150
150	7,8	160	160
200	8,4	180	180
250	9	350	245
300	9,6	400	275
350	10,2	300	300
400	10,8	325	325
450	11,4	350	350
500	12	375	—
600	13,2	425	—
700	14,4	480	—
800	15,6	530	—
900	16,8	580	—
1000	18	630	—
1100	19,2	695	—
1200	20,4	750	—
1400	22,8	775	—
1500	24	810	—
1600	25,2	845	—
1800	27,6	910	—
2000	30	980	—
2200	32,4	880	—
2400	34,8	945	—
2600	37,2	1 005	—

8.4.4 All flanged tees, DN 40 to DN 250

See Figure 18 and Table 26.

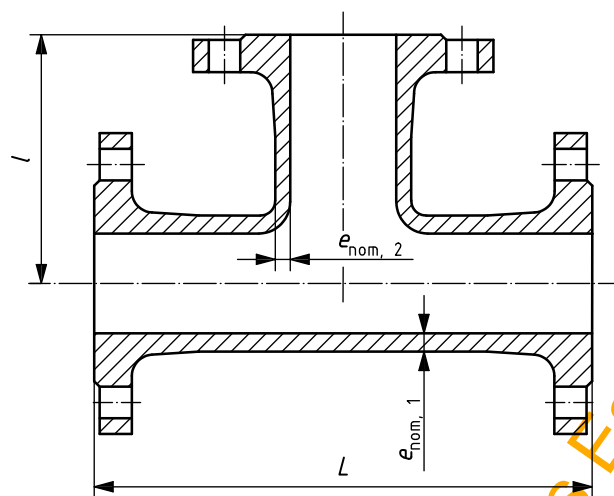

Figure 18 — All flanged tee

Draft for comments only — Not to be cited as East African Standard

Table 26 — Dimensions of all flanged tees, DN 40 to DN 250

DN × dn	Body			Branch		
	$e_{\text{nom}, 1}$	L		$e_{\text{nom}, 2}$	l	
		Series A	Series B		Series A	Series B
40 × 40	7	280	255	7	140	130
50 × 50	7	300	280	7	150	140
60 × 40	7	300	—	7	130	—
60 × 60	7	320	300	7	160	150
65 × 65	7	330	305	7	165	150
80 × 40	7	—	310	7	—	135
80 × 60	7	—	310	7	—	155
80 × 80	7	330	330	7	165	165
100 × 40	7,2	—	320	7	—	145
100 × 60	7,2	—	320	7	—	165
100 × 80	7,2	360	330	7	175	170
100 × 100	7,2	360	360	7,2	180	180
125 × 40	7,5	—	330	7	—	160
125 × 60	7,5	—	330	7	—	180
125 × 80	7,5	400	350	7	190	185
125 × 100	7,5	400	370	7,2	195	195
125 × 125	7,5	400	400	7,5	200	200
150 × 40	7,8	—	340	7	—	170
150 × 60	7,8	—	340	7	—	190
150 × 80	7,8	440	360	7	205	200
150 × 100	7,8	440	380	7,2	210	205
150 × 125	7,8	440	410	7,5	215	215
150 × 150	7,8	440	440	7,8	220	220
200 × 40	8,4	—	365	7	—	195
200 × 60	8,4	—	365	7	—	215
200 × 80	8,4	520	380	7	235	225
200 × 100	8,4	520	400	7,2	240	230
200 × 125	8,4	—	435	7,5	—	240
200 × 150	8,4	520	460	7,8	250	245
200 × 200	8,4	520	520	8,4	260	260
250 × 60	9	—	385	7	—	260
250 × 80	9	—	405	7	—	265
250 × 100	9	700	425	7,2	275	270
250 × 150	9	—	485	7,8	—	280
250 × 200	9	700	540	8,4	325	290
250 × 250	9	700	600	9	350	300

NOTE The main nominal size is designated DN and the nominal size of the branch is designated dn.

8.4.5 All flanged tees, DN 300 to DN 700

See Figure 18 and Table 27.

Table 27 — Dimensions of all flanged tees, DN 300 to DN 700

DN × dn	Body			Branch		
	$e_{nom, 1}$	L		$e_{nom, 2}$	l	
		Series A	Series B		Series A	Series B
300 × 60	9,6	—	405	7	—	290
300 × 80	9,6	—	425	7	—	295
300 × 100	9,6	800	450	7,2	300	300
300 × 150	9,6	—	505	7,8	—	310
300 × 200	9,6	800	565	8,4	350	320
300 × 250	9,6	—	620	9	—	330
300 × 300	9,6	800	680	9,6	400	340
350 × 60	10,2	—	430	7	—	320
350 × 80	10,2	—	445	7	—	325
350 × 100	10,2	850	470	7,2	325	330
350 × 150	10,2	—	530	7,8	—	340
350 × 200	10,2	850	585	8,4	325	350
350 × 250	10,2	—	645	9	—	360
350 × 350	10,2	850	760	10,2	425	380
400 × 80	10,8	—	470	7	—	355
400 × 100	10,8	900	490	7,2	350	360
400 × 150	10,8	—	550	7,8	—	370
400 × 200	10,8	900	610	8,4	350	380
400 × 250	10,8	—	665	9	—	390
400 × 300	10,8	—	725	9,6	—	400
400 × 400	10,8	900	840	10,8	450	420
450 × 100	11,4	950	515	7,2	375	390
450 × 150	11,4	—	570	7,8	—	400
450 × 200	11,4	950	630	8,4	375	410
450 × 250	11,4	—	690	9	—	420
450 × 300	11,4	—	745	9,6	—	430
450 × 400	11,4	—	860	10,8	—	450
450 × 450	11,4	950	920	11,4	475	460
500 × 100	12	1 000	535	7,2	400	420
500 × 200	12	1 000	650	8,4	400	440
500 × 400	12	1 000	885	10,8	500	480
500 × 500	12	1 000	1 000	12	500	500
600 × 200	13,2	1 100	700	8,4	450	500
600 × 400	13,2	1 100	930	10,8	550	540
600 × 600	13,2	1 100	1 165	13,2	550	580
700 × 200	14,4	650	—	8,4	525	—
700 × 400	14,4	870	—	10,8	555	—
700 × 700	14,4	1 200	—	14,4	600	—

NOTE The main nominal size is designated DN and the nominal size of the branch is designated dn.

8.4.6 All flanged tees, DN 800 to DN 2600

See Figure 18 and Table 28.

Table 28 — Dimensions of all flanged tees, DN 800 to DN 2600

DN × dn	Body		Branch	
	$e_{\text{nom}, 1}$	L Series A	$e_{\text{nom}, 2}$	/ Series A
800 × 200	15,6	690	8,4	585
800 × 400	15,6	910	10,8	615
800 × 600	15,6	1 350	13,2	645
800 × 800	15,6	1 350	15,6	675
900 × 200	16,8	730	8,4	645
900 × 400	16,8	950	10,8	675
900 × 600	16,8	1 500	13,2	705
900 × 900	16,8	1 500	16,8	750
1000 × 200	18	770	8,4	705
1000 × 400	18	990	10,8	735
1000 × 600	18	1 650	13,2	765
1000 × 1000	18	1 650	18	825
1100 × 400	19,2	980	8,4	795
1100 × 600	19,2	1 210	13,2	825
1200 × 600	20,4	1 240	13,2	885
1200 × 800	20,4	1 470	15,6	915
1200 × 1000	20,4	1 700	18	945
1400 × 600	22,8	1 550	13,2	980
1400 × 800	22,8	1 760	15,6	1 010
1400 × 1000	22,8	2 015	18	1 040
1500 × 600	24	1 575	13,2	1 035
1500 × 1000	24	2 040	18	1 095
1600 × 600	25,2	1 600	13,2	1 090
1600 × 800	25,2	1 835	15,6	1 120
1600 × 1000	25,2	2 065	18	1 150
1600 × 1200	25,2	2 300	20,4	1 180
1800 × 600	27,6	1 655	13,2	1 200
1800 × 800	27,6	1 885	15,6	1 230
1800 × 1000	27,6	2 120	18	1 260
1800 × 1200	27,6	2 350	20,4	1 290
2000 × 600	30	1 705	13,2	1 310
2000 × 1000	30	2 170	18	1 370
2000 × 1400	30	2 635	22,8	1 430
2200 × 600	32,4	1 560	13,2	1 420
2200 × 1200	32,4	1 220	20,4	1 510
2200 × 1800	32,4	2 880	27,6	1 600
2400 × 600	34,8	1 620	13,2	1 530
2400 × 1200	34,8	2 280	20,4	1 620
2400 × 1800	34,8	2 940	27,6	1 710
2600 × 600	37,2	1 680	13,2	1 640
2600 × 1400	37,2	2 560	22,8	1 760
2600 × 2000	37,2	3 220	30	1 850

NOTE The main nominal size is designated DN and the nominal size of the branch is designated dn.

8.4.7 Double-flanged tapers

See Figure 19 and Table 29.

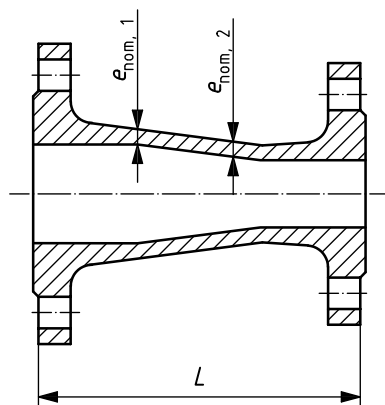

Figure 19 — Double-flanged taper

Draft for comments only — Not to be cited as East African Standard

Table 29 — Dimensions of double-flanged tapers

DN × dn	$e_{\text{nom}, 1}$	$e_{\text{nom}, 2}$	L	
			Series A	Series B
50 × 40	7	7	150	165
60 × 50	7	7	160	160
65 × 50	7	7	200	190
80 × 60	7	7	200	185
80 × 65	7	7	200	190
100 × 80	7,2	7	200	195
125 × 100	7,5	7,2	200	185
150 × 125	7,8	7,5	200	190
200 × 150	8,4	7,8	300	235
250 × 200	9	8,4	300	250
300 × 250	9,6	9	300	265
350 × 300	10,2	9,6	300	290
400 × 350	10,8	10,2	300	305
450 × 400	11,4	10,8	300	320
500 × 400	12	10,8	600	—
600 × 500	13,2	12	600	—
700 × 600	14,4	13,2	600	—
800 × 700	15,6	14,4	600	—
900 × 800	16,8	15,6	600	—
1000 × 900	18	16,8	600	—
1100 × 1000	19,2	18	600	—
1200 × 1000	20,4	18	790	—
1400 × 1200	22,8	20,4	850	—
1500 × 1400	24	22,8	695	—
1600 × 1400	25,2	22,8	910	—
1800 × 1600	27,6	25,2	970	—
2000 × 1800	30	27,6	1 030	—
2200 × 2000	32,4	30	1 090	—
2400 × 2200	34,8	32,4	1 150	—
2600 × 2400	37,2	34,8	1 210	—

NOTE The larger nominal size is designated DN and the smaller nominal size is designated by dn.

8.4.8 Blank flanges PN 10

See Figure 20 and Table 30.

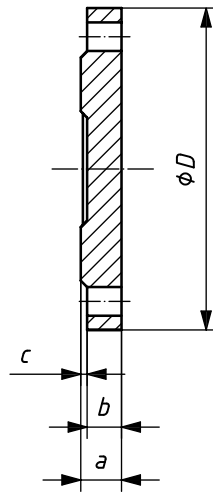

Figure 20 — Blank flange PN 10

8.4.9 Blank flanges PN 16

See Figure 21 and Table 30.

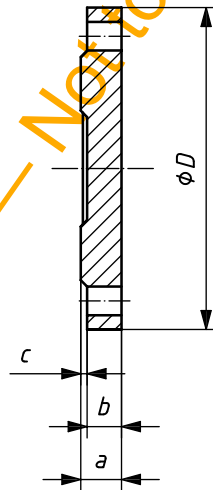

Figure 21 — Blank flange PN 16

Table 30 — Dimensions of PN 10 and PN 16 blank flanges

DN	PN 10				PN 16			
	<i>D</i>	<i>a</i>	<i>b</i>	<i>c</i>	<i>D</i>	<i>a</i>	<i>b</i>	<i>c</i>
40	150	19	16	3	150	19	16	3
50	165	19	16	3	165	19	16	3
60	175	19	16	3	175	19	16	3
65	185	19	16	3	185	19	16	3
80	200	19	16	3	200	19	16	3
100	220	19	16	3	220	19	16	3
125	250	19	16	3	250	19	16	3
150	285	19	16	3	285	19	16	3
200	340	20	17	3	340	20	17	3
250	400	22	19	3	400	22	19	3
300	455	24,5	20,5	4	455	24,5	20,5	4
350	505	24,5	20,5	4	520	26,5	22,5	4
400	565	24,5	20,5	4	580	28	24	4
450	615	25,5	21,5	4	640	30	26	4
500	670	26,5	22,5	4	715	31,5	27,5	4
600	780	30	25	5	840	36	31	5
700	895	32,5	27,5	5	910	39,5	34,5	5
800	1 015	35	30	5	1 025	43	38	5
900	1 115	37,5	32,5	5	1 125	46,5	41,5	5
1000	1 230	40	35	5	1 255	50	45	5
1100	1 340	42,5	37,5	5	1 355	53,5	48,5	5
1200	1 455	45	40	5	1 485	57	52	5
1400	1 675	46	41	5	1 685	60	55	5
1500	1 785	47,5	42,5	5	1 820	62,5	57,5	5
1600	1 915	49	44	5	1 930	65	60	5
1800	2 115	52	47	5	2 130	70	65	5
2000	2 325	55	50	5	2 345	75	70	5

For blank flanges of nominal diameter greater than or equal to DN 300, the centre of blank flanges may be dished.

8.4.10 Blank flanges PN 25

See Figure 22 and Table 31.

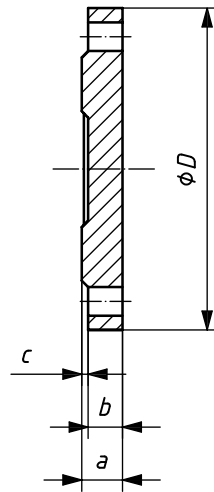

Figure 22 — Blank flange PN 25

8.4.11 Blank flanges PN 40

See Figure 23 and Table 31.

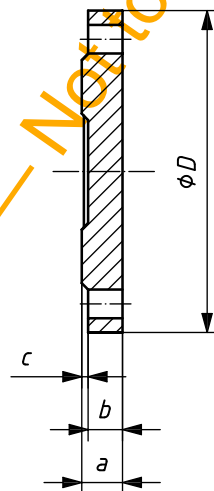

Figure 23 — Blank flange PN 40

Table 31 — Dimensions of PN 25 and PN 40 blank flanges

DN	PN 25				PN 40			
	<i>D</i>	<i>a</i>	<i>b</i>	<i>c</i>	<i>D</i>	<i>a</i>	<i>b</i>	<i>c</i>
40	150	19	16	3	150	19	16	3
50	165	19	16	3	165	19	16	3
60	175	19	16	3	175	19	16	3
65	185	19	16	3	185	19	16	3
80	200	19	16	3	200	19	16	3
100	235	19	16	3	235	19	16	3
125	270	19	16	3	270	23,5	20,5	3
150	300	20	17	3	300	26	23	3
200	360	22	19	3	375	30	27	3
250	425	24,5	21,5	3	450	34,5	31,5	3
300	485	27,5	23,5	4	515	39,5	35,5	4
350	555	30	26	4	—	—	—	—
400	620	32	28	4	—	—	—	—
450	670	34,5	30,5	4	—	—	—	—
500	730	36,5	32,5	4	—	—	—	—
600	845	42	37	5	—	—	—	—

For blank flanges of nominal diameter greater than or equal to DN 300, the centre of blank flanges may be dished.

8.4.12 Reducing flanges PN 10

See Figure 24 and Table 32.

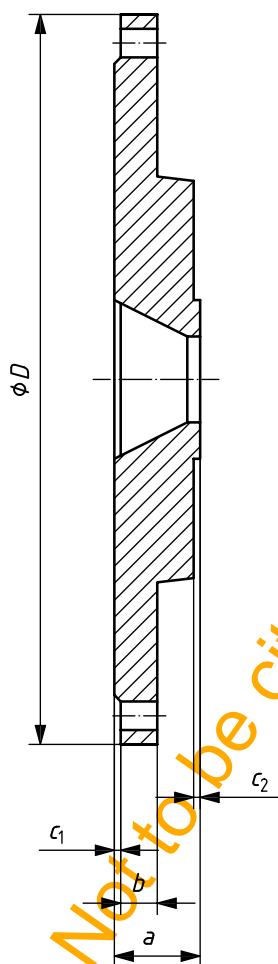

Figure 24 — Reducing flange PN 10

8.4.13 Reducing flanges PN 16

See Figure 25 and Table 32.

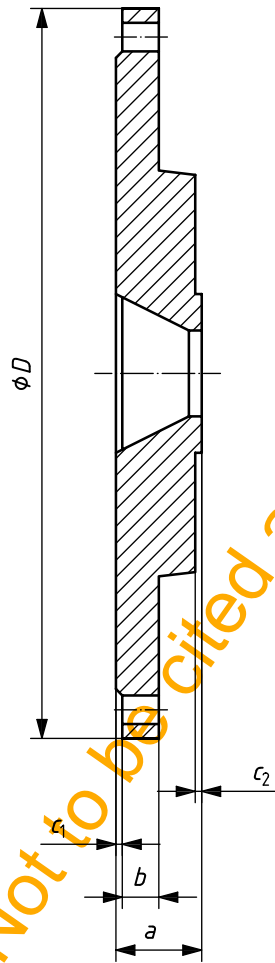

Figure 25 — Reducing flange PN 16

Table 32 — Dimensions of PN 10 and PN 16 reducing flanges

DN × dn	PN 10					PN 16				
	<i>D</i>	<i>a</i>	<i>b</i>	<i>c</i> ₁	<i>c</i> ₂	<i>D</i>	<i>a</i>	<i>b</i>	<i>c</i> ₁	<i>c</i> ₂
200 × 80	340	40	17	3	3	340	40	17	3	3
200 × 100	340	40	17	3	3	340	40	17	3	3
200 × 125	340	40	17	3	3	340	40	17	3	3
350 × 250	505	48	20,5	4	3	520	54	22,5	4	3
400 × 250	565	48	20,5	4	3	580	54	24	4	3
400 × 300	565	49	20,5	4	4	580	55	24	4	4
700 × 500	895	56	27,5	5	4	910	67	34,5	5	4
900 × 700	1 115	63	32,5	5	5	1 125	73	41,5	5	5
1000 × 700	1 230	63	35	5	5	1 255	73	45	5	5
1000 × 800	1 230	68	35	5	5	1 255	77	45	5	5

NOTE The larger nominal size is designated DN and the smaller nominal size is designated dn.

8.4.14 Reducing flanges PN 25

See Figure 26 and Table 33.

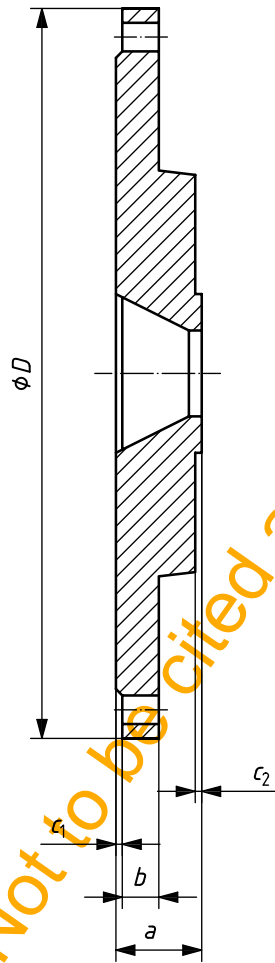

Figure 26 — Reducing flange PN 25

8.4.15 Reducing flanges PN 40

See Figure 27 and Table 33.

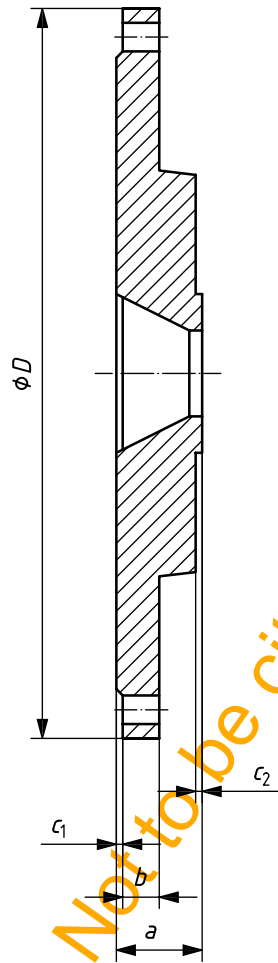

Figure 27 — Reducing flange PN 40

Table 33 — Dimensions of PN 25 and PN 40 reducing flanges

DN × dn	PN 25					PN 40				
	D	a	b	c_1	c_2	D	a	b	c_1	c_2
200 × 80	360	40	19	3	3	375	40	27	3	3
200 × 100	360	47	19	3	3	375	47	27	3	3
200 × 125	360	53	19	3	3	375	53	27	3	3
350 × 250	555	60	26	4	3	—	—	—	—	—
400 × 250	620	60	28	4	3	—	—	—	—	—
400 × 300	620	61	28	4	4	—	—	—	—	—

NOTE The larger nominal size is designated DN and the smaller size is designated dn.

Annex A (informative)

External protection

A.1 Factors characterizing aggressivity of external operating environments

- Resistivity;
- pH;
- water table level;
- stray currents;
- corrosion cells;
- contamination.

A.2 Centrifugally cast pipe coatings for protection against aggressive external operating environments

- Metallic zinc with finishing layer, in accordance with ISO 8179-1;
- zinc rich paint with finishing layer, in accordance with ISO 8179-2;
- polyethylene sleeving, in accordance with ISO 8180.

For other types of pipe coatings, including their repair method, refer to national standards or pipe manufacturers.

A.3 Fitting and accessory coatings for protection against aggressive external operating environments

- Metallic zinc with finishing layer, in accordance with ISO 8179-1;
- zinc rich paint with finishing layer, in accordance with ISO 8179-2;
- polyethylene sleeving, in accordance with ISO 8180.

For other types of fitting and accessory coatings, including their repair method, refer to national standards or pipe manufacturers.

Annex B
(informative)

Internal protection

B.1 Factors characterizing aggressivity of raw and potable waters

- pH;
- sulfates;
- magnesium;
- ammonium;
- aggressive CO₂.

B.2 Centrifugally cast pipe linings for protection against aggressive raw and potable waters

- Portland cement mortar, in accordance with ISO 4179;
- blast furnace slag cement mortar, in accordance with ISO 4179;
- cement mortar with seal coat, in accordance with ISO 16132.

For other types of pipe linings, including their repair method, refer to national standards or the pipe manufacturers.

B.3 Fitting and accessory linings for protection against aggressive raw and potable waters

- Portland cement mortar, in accordance with ISO 4179;
- blast furnace slag cement mortar, in accordance with ISO 4179;
- cement mortar with seal coat, in accordance with ISO 16132.

For other types of fitting and accessory linings, including their repair method, refer to national standards or the pipe manufacturers.

Annex C (informative)

Dimensions of preferred pressure classes and other pressure class pipes

Preferred classes and other classes of pipe are given in Table C.1.

The minimum nominal diameter available in lower pipe classes, i.e.

- C20 DN 700,
- C25 DN 350,
- C30 DN 300,

and the preferred pressure class/nominal diameter combinations given in Table 14 are limited by the minimum practical casting wall thickness and the values given reflect the manufacturing practices described in this International Standard.

Manufacturers can offer smaller diameters in these pressure classes provided they can demonstrate that the components comply with all the technical and performance requirements of this International Standard.

Draft for comments only — Not to be cited as East African Standard

Table C.1 — Dimensions of preferred and other classes of pipe

DN mm	DE ^a mm	Nominal iron wall thickness, e_{nom} mm ^b						
		C20	C25	C30	C40	C50	C64	C100
40	56				4,4 ^c	4,4	4,4	4,4
50	66				4,4 ^c	4,4	4,4	4,4
60	77				4,4 ^c	4,4	4,4	4,4
65	82				4,4 ^c	4,4	4,4	4,4
80	98				4,4 ^c	4,4	4,4	4,8
100	118				4,4 ^c	4,4	4,4	5,5
125	144				4,5 ^c	4,5	4,8	6,5
150	170				4,5 ^c	4,5	5,3	7,4
200	222				4,7 ^c	5,4	6,5	9,2
250	274				5,5 ^c	6,4	7,8	11,1
300	326			5,1	6,2 ^c	7,4	8,9	12,9
350	378		5,1	6,3 ^{c d}	7,1	8,4	10,2	14,8
400	429		5,5	6,5 ^{c d}	7,8	9,3	11,3	16,5
450	480		6,1	6,9 ^c	8,6	10,3	12,6	18,4
500	532		6,5	7,5 ^c	9,3	11,2	13,7	20,2
600	635		7,6	8,7 ^c	10,9	13,1	16,1	23,8
700	738	7,3	8,8 ^{c d}	9,9	12,4	15,0	18,5	27,5
800	842	8,1	9,6 ^c	11,1	14,0	16,9	21,0	
900	945	8,9	10,6 ^c	12,3	15,5	18,8	23,4	
1000	1 048	9,8	11,6 ^c	13,4	17,1	20,7		
1100	1 152	10,6	12,6 ^c	14,7	18,7	22,7		
1200	1 255	11,4	13,6 ^c	15,8	20,2			
1400	1 462	13,1	15,7 ^c	18,2				
1500	1 565	13,9	16,7 ^c	19,4				
1600	1 668	14,8	17,7 ^c	20,6				
1800	1 875	16,4	19,7 ^c	23,0				
2000	2 082	18,1	21,8 ^c	25,4				
2200	2 288	19,8	23,8 ^c					
2400	2 495	21,4	25,8 ^c					
2600	2 702	23,1	27,9 ^c					

^a A tolerance of +1 mm applies (see 4.2.2.1).

^b For pipes with weld beads, see ISO 10804.

^c Preferred classes.

^d For preferred classes, thicknesses are greater than calculated for “smoothing” between C40 and C30 and also between C30 and C25.

Annex D (normative)

Pipe wall thicknesses, stiffness and diametral deflection

D.1 General

Ductile iron pipes can undergo large diametral deflections in operation while keeping all their functional characteristics. Allowable pipe diametral deflections, when the pipeline is in service, are given in Tables D.1 to D.7, together with their minimum diametral stiffnesses, which allow the pipes to withstand large heights of cover and/or heavy traffic loads in a wide range of installation conditions.

D.2 Stiffness and diametral deflection

The diametral deflection, in percent, is one hundred times the vertical pipe deflection, in millimetres, divided by the initial pipe external diameter, DE, in millimetres. The values of allowable diametral deflection given in Tables D.1 to D.7 apply to cement-lined C20, C25, C30, C40, C50, C64 and C100 pipes; they provide joint integrity as well as safety against overstressing of the pipe wall and excessive cracking of the lining. The maximum allowable deflection of cement-mortar-lined pipe is 4 %. National standards and manufacturers' handbooks may introduce more stringent limitations, such as 3 %.

The maximum allowable deflection for other types of linings can be calculated in accordance with ISO 10803.

The diametral stiffness, S , of a pipe is calculated using Equation (D.1):

$$S = 1\,000 \frac{E \times I}{D^3} = 1\,000 \frac{E}{12} (e_{\text{stiff}}/D)^3 \quad (\text{D.1})$$

where

S is the diametral stiffness, in kilonewtons per square metre;

E is the modulus of elasticity of the material, in megapascals (170 000 MPa);

I is the second moment of area of the pipe wall per unit length, in millimetres, to the third power;

e_{stiff} is the minimum wall thickness of the pipe, e_{min} , plus half the tolerance, in millimetres;

D is the mean diameter of the pipe ($DE - e_{\text{stiff}}$), in millimetres;

where

DE is the nominal pipe outer diameter, in millimetres.

Table D.1 — Diametral stiffness and allowable deflection of Class 20 pipe

Pressure class C20						
DN	DE	Minimum thickness	Nominal thickness	Minimum + half tolerance	Minimum stiffness	Allowable deflection
mm	mm	e_{\min} mm	e_{nom} mm	e_{stiff} mm	S kN/m ²	%
700	738	5,3	7,3	6,30	9	3,80
800	842	6,0	8,1	7,05	9	4,00
900	945	6,7	8,9	7,80	9	4,00
1000	1 048	7,5	9,8	8,65	8	4,00
1100	1 152	8,2	10,6	9,40	8	4,00
1200	1 255	8,9	11,4	10,15	8	4,00
1400	1 462	10,4	13,1	11,75	8	4,00
1500	1 565	11,1	13,9	12,50	7	4,00
1600	1 668	11,9	14,8	13,35	7	4,00
1800	1 875	13,3	16,4	14,85	7	4,00
2000	2 082	14,8	18,1	16,45	7	4,00
2200	2 288	16,3	19,8	18,05	7	4,00
2400	2 495	17,7	21,4	19,55	7	4,00
2600	2 702	19,2	23,1	21,15	7	4,00

NOTE The values of S and deflection have been calculated assuming a pipe wall thickness equal to the minimum thickness plus half of the tolerance, to take into account that there are only a few points with a thickness equal or close to the minimum thickness.

Table D.2 — Diametral stiffness and allowable deflection of Class 25 pipe

Pressure class C25						
DN	DE	Minimum thickness	Nominal thickness	Minimum + half tolerance	Minimum stiffness	Allowable deflection
mm	mm	e_{\min} mm	e_{nom} mm	e_{stiff} mm	S kN/m ²	%
350	378	3,4	5,1	4,25	21	3,10
400	429	3,8	5,5	4,65	19	3,20
450	480	4,3	6,1	5,20	19	3,30
500	532	4,7	6,5	5,60	17	3,40
600	635	5,7	7,6	6,65	17	3,60
700	738	6,8 ^a	8,8 ^a	7,80 ^a	17	3,80
800	842	7,5	9,6	8,55	15	4,00
900	945	8,4	10,6	9,50	15	4,00
1000	1 048	9,3	11,6	10,45	14	4,00
1100	1 152	10,2	12,6	11,40	14	4,00
1200	1 255	11,1	13,6	12,35	14	4,00
1400	1 462	13,0	15,7	14,35	14	4,00
1500	1 565	13,9	16,7	15,30	14	4,00
1600	1 668	14,8	17,7	16,25	13	4,00
1800	1 875	16,6	19,7	18,15	13	4,00
2000	2 082	18,5	21,8	20,15	13	4,00
2200	2 288	20,3	23,8	22,05	13	4,00
2400	2 495	22,1	25,8	23,95	13	4,00
2600	2 702	24,0	27,9	25,95	13	4,00

NOTE The values of S and deflection have been calculated assuming a pipe wall thickness equal to the minimum thickness plus half of the tolerance, to take into account that there are only a few points with a thickness equal or close to the minimum thickness.

^a Thicknesses are greater than calculated for "smoothing" between C30 and C25 in the preferred classes.

Table D.3 — Diametral stiffness and allowable deflection of Class 30 pipe

Pressure class C30						
DN	DE	Minimum thickness	Nominal thickness	Minimum + half tolerance	Minimum stiffness	Allowable deflection
mm	mm	e_{min} mm	e_{nom} mm	e_{stiff} mm	S kN/m ²	%
300	326	3,5	5,1	4,30	34	3,00
350	378	4,6 ^a	6,3 ^a	5,45 ^a	44	3,10
400	429	4,8 ^a	6,5 ^a	5,65 ^a	34	3,20
450	480	5,1	6,9	6,00	29	3,30
500	532	5,7	7,5	6,60	28	3,40
600	635	6,8	8,7	7,75	27	3,60
700	738	7,9	9,9	8,90	26	3,80
800	842	9,0	11,1	10,05	25	4,00
900	945	10,1	12,3	11,20	24	4,00
1000	1 048	11,1	13,4	12,25	23	4,00
1100	1 152	12,3	14,7	13,50	24	4,00
1200	1 255	13,3	15,8	14,55	23	4,00
1400	1 462	15,5	18,2	16,85	22	4,00
1500	1 565	16,6	19,4	18,00	22	4,00
1600	1 668	17,7	20,6	19,15	22	4,00
1800	1 875	19,9	23,0	21,45	22	4,00
2000	2 082	22,1	25,4	23,75	22	4,00

NOTE The values of S and deflection have been calculated assuming a pipe wall thickness equal to the minimum thickness plus half of the tolerance, to take into account that there are only a few points with a thickness equal or close to the minimum thickness.

^a Thicknesses are greater than calculated for "smoothing" between C40 and C30 in the preferred classes.

Table D.4 — Diametral stiffness and allowable deflection of Class 40 pipe

Pressure class C40						
DN	DE	Minimum thickness	Nominal thickness	Minimum + half tolerance	Minimum stiffness	Allowable deflection
mm	mm	e_{\min} mm	e_{nom} mm	e_{stiff} mm	S kN/m ²	%
40	56	3,0	4,4	3,70	5 016	0,75
50	66	3,0	4,4	3,70	2 968	0,90
60	77	3,0	4,4	3,70	1 822	1,10
65	82	3,0	4,4	3,70	1 495	1,15
80	98	3,0	4,4	3,70	856	1,40
100	118	3,0	4,4	3,70	481	1,70
125	144	3,0	4,5	3,75	271	2,05
150	170	3,0	4,5	3,75	163	2,45
200	222	3,2	4,7	3,95	84	3,00 ^a
250	274	3,9	5,5	4,70	75	3,00 ^a
300	326	4,6	6,2	5,40	68	3,00
350	378	5,4	7,1	6,25	67	3,10
400	429	6,1	7,8	6,95	63	3,20
450	480	6,8	8,6	7,70	61	3,30
500	532	7,5	9,3	8,40	58	3,40
600	635	9,0	10,9	9,95	57	3,50
700	738	10,4	12,4	11,40	55	3,55
800	842	11,9	14,0	12,95	54	3,55
900	945	13,3	15,5	14,40	52	3,60
1000	1 048	14,8	17,1	15,95	52	3,60
1100	1 152	16,3	18,7	17,50	52	3,60
1200	1 255	17,7	20,2	18,95	51	3,60

NOTE The values of S and deflection have been calculated assuming a pipe wall thickness equal to the minimum thickness plus half of the tolerance, to take into account that there are only a few points with a thickness equal or close to the minimum thickness.

^a Allowable deflection is limited to a lower value than that described in ISO 10803 for consistency of design.

Table D.5 — Diametral stiffness and allowable deflection of Class 50 pipe

Pressure class C50						
DN	DE	Minimum thickness	Nominal thickness	Minimum + half tolerance	Minimum stiffness	Allowable deflection
mm	mm	e_{min} mm	e_{nom} mm	e_{stiff} mm	S kN/m ²	%
40	56	3,0	4,4	3,70	5016	0,75
50	66	3,0	4,4	3,70	2968	0,90
60	77	3,0	4,4	3,70	1822	1,10
65	82	3,0	4,4	3,70	1495	1,15
80	98	3,0	4,4	3,70	856	1,40
100	118	3,0	4,4	3,70	481	1,70
125	144	3,0	4,5	3,75	271	2,05
150	170	3,0	4,5	3,75	163	2,45
200	222	3,9	5,4	4,65	139	2,60
250	274	4,8	6,4	5,60	129	2,65
300	326	5,8	7,4	6,60	125	2,70
350	378	6,7	8,4	7,55	120	2,70
400	429	7,6	9,3	8,45	115	2,75
450	480	8,5	10,3	9,40	113	2,80
500	532	9,4	11,2	10,30	109	2,80
600	635	11,2	13,1	12,15	105	2,85
700	738	13,0	15,0	14,00	102	2,85
800	842	14,8	16,9	15,85	100	2,90
900	945	16,6	18,8	17,70	99	2,90
1000	1 048	18,4	20,7	19,55	97	2,90
1100	1 152	20,3	22,7	21,50	97	2,90

NOTE The values of S and deflection have been calculated assuming a pipe wall thickness equal to the minimum thickness plus half of the tolerance, to take into account that there are only a few points with a thickness equal or close to the minimum thickness.

Table D.6 — Diametral stiffness and allowable deflection of Class 64 pipe

Pressure class C64						
DN	DE	Minimum thickness	Nominal thickness	Minimum + half tolerance	Minimum stiffness	Allowable deflection
mm	mm	e_{\min} mm	e_{nom} mm	e_{stiff} mm	S kN/m ²	%
40	56	3,0	4,4	3,70	5016	0,75
50	66	3,0	4,4	3,70	2968	0,90
60	77	3,0	4,4	3,70	1822	1,10
65	82	3,0	4,4	3,70	1495	1,15
80	98	3,0	4,4	3,70	856	1,40
100	118	3,0	4,4	3,70	481	1,70
125	144	3,3	4,8	4,05	343	1,90
150	170	3,8	5,3	4,55	295	2,00
200	222	5,0	6,5	5,75	266	2,10
250	274	6,2	7,8	7,00	255	2,10
300	326	7,3	8,9	8,10	234	2,15
350	378	8,5	10,2	9,35	231	2,20
400	429	9,6	11,3	10,45	220	2,20
450	480	10,8	12,6	11,70	221	2,20
500	532	11,9	13,7	12,80	212	2,25
600	635	14,2	16,1	15,15	207	2,25
700	738	16,5	18,5	17,50	203	2,30
800	842	18,9	21,0	19,95	202	2,30
900	945	21,2	23,4	22,30	200	2,30

NOTE The values of S and deflection have been calculated assuming a pipe wall thickness equal to the minimum thickness plus half of the tolerance, to take into account that there are only a few points with a thickness equal or close to the minimum thickness.

Table D.7 — Diametral stiffness and allowable deflection of Class 100 pipe

Pressure class C100						
DN	DE	Minimum thickness	Nominal thickness	Minimum + half tolerance	Minimum stiffness	Allowable deflection
mm	mm	e_{\min} mm	e_{nom} mm	e_{stiff} mm	S kN/m ²	%
40	56	3,0	4,4	3,70	5016	0,75
50	66	3,0	4,4	3,70	2968	0,90
60	77	3,0	4,4	3,70	1822	1,10
65	82	3,0	4,4	3,70	1495	1,15
80	98	3,4	4,8	4,10	1179	1,25
100	118	4,1	5,5	4,80	1080	1,30
125	144	5,0	6,5	5,75	1019	1,30
150	170	5,9	7,4	6,65	956	1,35
200	222	7,7	9,2	8,45	878	1,40
250	274	9,5	11,1	10,30	844	1,40
300	326	11,3	12,9	12,10	811	1,40
350	378	13,1	14,8	13,95	797	1,45
400	429	14,8	16,5	15,65	769	1,45
450	480	16,6	18,4	17,50	767	1,45
500	532	18,4	20,2	19,30	756	1,45
600	635	21,9	23,8	22,85	737	1,50
700	738	25,5	27,5	26,50	732	1,50

NOTE The values of S and deflection have been calculated assuming a pipe wall thickness equal to the minimum thickness plus half of the tolerance, to take into account that there are only a few points with a thickness equal or close to the minimum thickness.

Annex E (normative)

Quality assurance

E.1 General

The manufacturer has the responsibility to demonstrate the conformity of his products with this International Standard by:

- carrying out type tests (see E.2);
- controlling the quality of the manufacturing process (see E.3).

E.2 Type tests

The type tests specified in Clauses 5 and 7 are carried out either by the manufacturer or, at his request, by a competent testing institute in order to demonstrate compliance with the requirements of this International Standard. Full reports of these type tests are retained by the supplier of pipes, fittings and gaskets as evidence of compliance.

If fittings or gaskets are supplied separately from pipes, full reports of the type tests on these components, and their compatibility with pipes, shall be made available to the client by the fitting or gasket suppliers.

E.3 Quality control

The manufacturer controls the quality of his products during their manufacture by a system of process control in order to comply with the technical requirements of this International Standard.

It is recommended that the manufacturer's quality system conform to ISO 9001.

If certification to ISO 9001 is involved, it is recommended that the certification body be accredited to the relevant International Standard, as applicable.

Annex F
(informative)**Safety factors**

The following safety factors are used in the design for minimum thicknesses for ductile iron pipes:

Table F.1 — Safety factors for ductile iron pipes

Design criteria	Safety factor	Mechanical property
PFA	3,0	Minimum ultimate tensile strength of 420 MPa
PMA	2,5	Minimum ultimate tensile strength of 420 MPa
External loads	1,5	Yield bending strength of 500 MPa

Bibliography

- [1] ISO 4179:2005, *Ductile iron pipes and fittings for pressure and non-pressure pipelines — Cement mortar lining*
- [2] ISO 6708:—²⁾, *Pipework components — Definition and selection of DN, NPS and A*
- [3] ISO 7268, *Pipe components — Definition and selection of PN, Class and K*
- [4] ISO 8179-1, *Ductile iron pipes — External zinc-based coating — Part 1: Metallic zinc with finishing layer*
- [5] ISO 8179-2, *Ductile iron pipes — External zinc coating — Part 2: Zinc rich paint with finishing layer*
- [6] ISO 8180, *Ductile iron pipelines — Polyethylene sleeving for site application*
- [7] ISO 9001, *Quality management systems — Requirements*
- [8] ISO 16132, *Ductile iron pipes and fittings — Seal coats for cement mortar linings*

2) Under revision.

ICS 77.140.75; 91.140.40; 91.140.60

Price based on 73 pages

Draft for comments only — Not to be cited as East African Standard