



## **EAST AFRICAN STANDARD**

---

**Suitability of non-metallic products for use in contact with water intended for human consumption with regard to their effect on the quality of the water — Part 4: Method for the GCMS identification of water leachable organic substances**

**EAST AFRICAN COMMUNITY**

---

## Foreword

Development of the East African Standards has been necessitated by the need for harmonizing requirements governing quality of products and services in East Africa. It is envisaged that through harmonized standardization, trade barriers which are encountered when goods and services are exchanged within the Community will be removed.

In order to meet the above objectives, the EAC Partner States have enacted an East African Standardization, Quality Assurance, Metrology and Test Act, 2006 (EAC SQMT Act, 2006) to make provisions for ensuring standardization, quality assurance, metrology and testing of products produced or originating in a third country and traded in the Community in order to facilitate industrial development and trade as well as helping to protect the health and safety of society and the environment in the Community.

East African Standards are formulated in accordance with the procedures established by the East African Standards Committee. The East African Standards Committee is established under the provisions of Article 4 of the EAC SQMT Act, 2006. The Committee is composed of representatives of the National Standards Bodies in Partner States, together with the representatives from the private sectors and consumer organizations. Draft East African Standards are circulated to stakeholders through the National Standards Bodies in the Partner States. The comments received are discussed and incorporated before finalization of standards, in accordance with the procedures of the Community.

Article 15(1) of the EAC SQMT Act, 2006 provides that "Within six months of the declaration of an East African Standard, the Partner States shall adopt, without deviation from the approved text of the standard, the East African Standard as a national standard and withdraw any existing national standard with similar scope and purpose".

East African Standards are subject to review, to keep pace with technological advances. Users of the East African Standards are therefore expected to ensure that they always have the latest versions of the standards they are implementing.

© East African Community 2010 — All rights reserved\*

East African Community

P O Box 1096

**Arusha**

Tanzania

Tel: 255 27 2504253/8

Fax: 255-27-2504481/2504255

E-Mail: [eac@eachq.org](mailto:eac@eachq.org)

Web: [www.each.int](http://www.each.int)

---

\* © 2010 EAC — All rights of exploitation in any form and by any means reserved worldwide for EAC Partner States' NSBs.

## Introduction

Chemicals that leach from materials used in contact with public water supplies can cause health concerns for consumers. Potential health effects of these chemicals are assessed in three stages:

- 1) preparation of leachates by exposing a portion of the material to water under controlled conditions;
- 2) analysis of the leachates;
- 3) toxicological evaluation of the concentrations of substances identified. Analysis of organic substances present in the leachates usually involves two types of analytical method:
  - a screening method which enables a qualitative and semi-quantitative assessment to be made of unspecified organic compounds;
  - accurate quantitative methods for the determination of specific target compounds known to be present in the chemical formulations of the materials.

In the preparation of this East African Standard, the following source was consulted extensively:

BS 6920-3:2000, *Suitability of non-metallic products for use in contact with water intended for human consumption with regard to their effect on the quality of the water — Part 4: Method for the GCMS identification of water leachable organic substances*

Assistance derived from this source and others inadvertently not mentioned is hereby acknowledged.

# **Suitability of non-metallic products for use in contact with water intended for human consumption with regard to their effect on the quality of the water —**

## **Part 4: Method for the GCMS identification of water leachable organic substances**

ICS 13.060.20; 13.060.50

## **Committees responsible for this British Standard**

The preparation of this British Standard was entrusted by Technical Committee EH/3, Water quality, to Subcommittee EH/3/7, Effects of materials on water quality, upon which the following bodies were represented:

- Association of Manufacturers of Domestic Electrical Appliances
- Automatic Vending Association of Britain
- British Bathroom Council
- British Cement Association
- British Coatings Federation Ltd.
- British Malleable Tube Fittings Association
- British Non-Ferrous Metals Federation
- British Plastics Federation
- British Plumbing Fittings Manufacturers' Association
- British Precast Concrete Federation Ltd.
- British Rubber Manufacturers' Association
- British Valve and Actuator Manufacturers' Association
- British Water
- Department of the Environment for Northern Ireland
- The Drinking Water Inspectorate
- Galvanizers Association
- Laboratory of the Government Chemist
- Lead Development Association
- Pipeline Industries Guild
- UK Steel Association
- UK Water Byelaws Scheme
- Water Research Centre
- Water UK
- Zinc Development Association

This British Standard, having been prepared under the direction of the Health and Environment Sector Committee, was published under the authority of the Standards Committee and comes into effect on 15 July 2001

© BSI 07-2001

### **Amendments issued since publication**

Amd. No.	Date	Comments

The following BSI references relate to the work on this standard:  
Committee reference EH/3/7  
Draft for comment 00/561599 DC

**ISBN 0 580 33274 8**

## Contents

	Page
Committees responsible	Inside front cover
Foreword	ii
<hr/>	
Introduction	1
1 Scope	1
2 Terms and definitions	1
3 Principle	3
4 Reagents	3
5 Apparatus	5
6 Leachate	6
7 Method of analysis	6
8 Expression of results	9
9 Test report	10
<hr/>	
Annex A (informative) Procedure for preparing test leachates	12
Annex B (informative) Methods for sealing the ends of pipe sections	18
Annex C (informative) Suitable methods for preparing extracts from large diameter pipes	20
Annex D (informative) Additional procedural details	23
<hr/>	
Bibliography	27
<hr/>	
Figure A.1 — Test sequence — Factory made	13
Figure A.2 — Test sequence — Site applied products	14
Figure B.1 — Metal clamp to seal pipe sections	18
Figure C.1 — Test arrangement 1	21
Figure C.2 — Test arrangement 2	22
<hr/>	
Table D.1 — Within-laboratory performance data for internal standards	25
Table D.2 — Summary of variation (% RSD) for internal standards in interlaboratory performance testing	26
<hr/>	

## Foreword

This part of this British Standard has been prepared by Subcommittee EH/3/7, Effects of materials on water quality. It is a revision of BS 6920-4:1997, which is now withdrawn.

This standard contains technical revisions to the test method, based upon experience of using this method. In addition, the main part of the (normative) text for leachate preparation (clause 8 in the 1997 edition) has been transferred to a new informative Annex A to allow variations in leachate preparation conditions to be specified by the National Regulator.

BS 6920 is published in several other parts, namely:

- Part 1: *Specification*;
- Part 2: *Methods of test*;
- Part 3: *High temperature tests*.

Part 2 is further sub-divided into a number of sections and subsections as follows:

Section 2.1	<i>Samples for testing;</i>
Section 2.2	<i>Odour and flavour of water;</i>
Subsection 2.2.1	<i>General method of test;</i>
Subsection 2.2.2	<i>Method of testing tastes imparted to water by hoses;</i>
Subsection 2.2.3	<i>Method of testing tastes imparted to water by hoses for conveying water for food and drink preparation;</i>
Section 2.3	<i>Appearance of water;</i>
Section 2.4	<i>Growth of aquatic micro-organisms;</i>
Section 2.5	<i>The extraction of substances that may be of concern to public health;</i>
Section 2.6	<i>The extraction of metals.</i>

Annex A, Annex B, Annex C and Annex D are informative.

This part of this British Standard describes methods of identification only, and should not be used or quoted as a specification. References to this standard should indicate that the methods of identification used are in accordance with BS 6920-4.

This British Standard calls for the use of substances and/or procedures that may be injurious to health if adequate precautions are not taken. It refers only to technical suitability and does not absolve the user from legal obligations relating to health and safety at any stage.

A British Standard does not purport to include all the necessary provisions of a contract. Users of British Standards are responsible for their correct application.

**Compliance with a British Standard does not of itself confer immunity from legal obligations.**

### Summary of pages

This document comprises a front cover, an inside front cover, pages i and ii, pages 1 to 27 and a back cover.

The BSI copyright notice displayed in this document indicates when the document was last issued.

## Introduction

Chemicals that leach from materials used in contact with public water supplies can cause health concerns for consumers. Potential health effects of these chemicals are assessed in three stages:

- 1) preparation of leachates by exposing a portion of the material to water under controlled conditions;
- 2) analysis of the leachates;
- 3) toxicological evaluation of the concentrations of substances identified.

Analysis of organic substances present in the leachates usually involves two types of analytical method:

- a screening method which enables a qualitative and semi-quantitative assessment to be made of unspecified organic compounds;
- accurate quantitative methods for the determination of specific target compounds known to be present in the chemical formulations of the materials.

This part of BS 6920 describes the analytical procedures based upon gas chromatography and mass spectrometry (GCMS) used to screen leachates for unspecified organic compounds derived from finished products such as pipes, protective coatings, membranes, etc.

This method is suitable for leachates from all non-metallic materials that could be used in contact with water for human consumption, and which could be the subject of an application for approval by the National Regulator. In addition, Annex A gives general guidance on the preparation of test samples and their leachates.

**NOTE 1** At the time of publication, products for use in contact with public water supply must be approved by the Secretary of State for the Environment under the provisions of regulation 25(1)(a) of the Water Supply (Water Quality) Regulations 1989 [1], unless any of the subsections 25(1)(b), (c) or (d) applies. The methods described in this section of BS 6920 may form the basis of leaching test specifications issued by the committee that advises the Secretary of State on the approval of substances and products for use in contact with public water supplies. Equivalent provisions apply in Scotland and Northern Ireland.

**NOTE 2** The results of these tests are assessed by reference to existing toxicological data concerning the chemicals identified. Where little or no information exists, it might be necessary for the substance itself or the material leachate to be submitted for toxicity testing.

## 1 Scope

This part of BS 6920 describes a method for identifying organic chemicals that are amenable to GCMS analysis using the techniques described and which might leach from a product into water intended for human consumption. A method of calculating the concentrations of the organic substances identified is also provided.

This part of this British Standard is not applicable to the toxicological evaluation of chemicals.

**NOTE** The method to be used for the preparation of leachates will be specified by the National Regulator. Annex A provides a suitable method for preparing these leachates.

## 2 Terms and definitions

For the purposes of this British Standard, the following terms and definitions apply.

### 2.1

#### **amu**

#### **atomic mass unit**

defined as 1/12 of the mass of a single atom of carbon-12 in the gas phase (i.e. unbound), at rest and in its ground state



**2.10*****m/z***

mass-to-charge ratio of an ion

NOTE As most ions produced by electron impact ionization are singly charged, this ratio usually corresponds to the mass of an ion. However, exceptionally, ions can possess multiple charges.

**2.11****solvent extract**

solution containing compounds partitioned from the leachate into the extraction solvent

**2.12****total ion current****TIC**

sum of all the separate ion currents carried by the individual ions contributing to a mass spectrum

**2.13****TIC chromatogram**

graphical representation of the TIC versus time

**3 Principle**

A mixture of internal standards is added to each of the test leachates prior to solvent extraction with dichloromethane. The solvent extract is concentrated and analysed by GCMS to determine the identity and approximate concentrations of organic chemicals that could be present.

The mass spectrometer is used in a repetitive full-scan mode and the mass spectra produced are recorded by, and stored on, the GCMS data system.

Wherever possible, each compound detected is identified and may be quantified by reference to the responses obtained for the internal standards.

NOTE 1 The number and duration of leaching (migration) periods, the nature of the test sample(s) and the test surface area to volume ratio are specified by the National Regulator based upon the nature of the product and its proposed use. Annex A provides a typical "model" for the preparation of leachates based upon the current requirements of the National Regulator.

NOTE 2 The methods used to identify organic compounds from their mass spectra do not form part of this method, but further information on this subject is given in Annex D.

**4 Reagents**

**4.1** Only reagents of analytical grade shall be used, except where otherwise specified. All reagents shall be of sufficient purity to ensure that they do not give rise to interferences during the GCMS analysis.

NOTE Contamination can arise from various sources, e.g. plastics or rubber materials. The use of procedural blanks and laboratory blanks assists in detecting and identifying the source of any contamination.

**4.2** *Reagent water*, having a conductivity of <2 mS/m, a total organic carbon content of <0.2 mg/l carbon, and free from organic contaminants which would interfere with the GCMS analysis of the extracts.

NOTE Suitable water may be prepared by reverse osmosis, deionization or distillation.

**4.3** *Hydrochloric acid*, concentrated (30 % *m/V*).

**4.4** *Hydrochloric acid solution*, prepared as follows.

Slowly add (0.5 ± 0.01) l of concentrated hydrochloric acid (4.3) to (0.5 ± 0.01) l of reagent water (4.2).

NOTE 1 Care is needed in preparing this solution which can generate heat.

NOTE 2 This solution should be replaced on a monthly basis.

**4.5** *Nitric acid*, concentrated (65 % *m/V*).

**4.6** *Nitric acid solution*, prepared as follows.

Slowly add (0.5 ± 0.01) l of concentrated nitric acid (4.5) to (0.5 ± 0.01) l of reagent water (4.2).

NOTE Care is needed in preparing this solution which can generate heat.

**4.7 Sulfuric acid**, concentrated (98 % m/V).

**4.8 Sulfuric acid solution (0.5 mol/l)**, prepared as follows.

Slowly add (14.0 ± 0.5) ml of sulfuric acid (4.7) to (300 ± 5) ml of reagent water (4.2) and make up to (500 ± 5) ml with reagent water.

NOTE Care is needed in preparing this solution which can generate heat.

**4.9 Chromic acid (5 % m/V)**, prepared as follows.

Dissolve (50 ± 1) g of chromium(VI) oxide in (1 ± 0.02) l of sulfuric acid (4.7).

NOTE Chromic acid is a storage hazard; it can burst a sealed container due to carbon dioxide release. It is a powerful oxidant and can give potentially explosive reactions with oxidizable materials. It can ignite on contact with acetone or alcohols. When heated to decomposition, it emits acrid smoke and irritating fumes.

**4.10 Sodium hydroxide solution (0.5 mol/l)**, prepared as follows.

Dissolve (20.0 ± 0.1) g of sodium hydroxide pellets in test water and make up to 1 l.

NOTE Replace this solution on a monthly basis.

**4.11 Dichloromethane**, glass distilled grade.

NOTE Other grades may be suitable but it is necessary to demonstrate that any impurities present do not interfere with the detection of compounds of interest or the internal standards, or introduce unacceptable contamination.

**4.12 Acetone**, glass distilled grade.

NOTE Other grades may be suitable but it is necessary to demonstrate that any impurities present do not interfere with the detection of compounds of interest or the internal standards, or introduce unacceptable contamination.

**4.13 Ascorbic acid solution**, prepared as follows.

Dissolve (4.0 ± 0.1) g of ascorbic acid in (1.0 ± 0.01) l test water. Prior to use, extract this solution with dichloromethane (2 × 200 ml).

NOTE This solution should be replaced on a monthly basis.

**4.14 Internal standards**, use the following isotopically-labelled compounds:

- d<sub>6</sub>-benzene;
- d<sub>21</sub>-2,6-di-*t*-butyl-4-methylphenol (d<sub>21</sub>-BHT);
- d<sub>5</sub>-chlorobenzene;
- d<sub>34</sub>-hexadecane;
- d<sub>8</sub>-naphthalene;
- d<sub>10</sub>-phenanthrene;
- d<sub>5</sub>-phenol;
- d<sub>62</sub>-squalane;
- d<sub>10</sub>-*p*-xylene.

**4.15 Internal standards stock solutions**, prepared as follows.

Make up in acetone (4.12) as follows:

d <sub>6</sub> -benzene	(2.0 ± 0.05) mg/ml;
d <sub>21</sub> -BHT	(8.0 ± 0.20) mg/ml;
d <sub>5</sub> -chlorobenzene	(2.0 ± 0.05) mg/ml;
d <sub>34</sub> -hexadecane	(1.0 ± 0.02) mg/ml;
d <sub>8</sub> -naphthalene	(1.0 ± 0.02) mg/ml;
d <sub>10</sub> -phenanthrene	(2.0 ± 0.05) mg/ml;
d <sub>5</sub> -phenol	(8.0 ± 0.20) mg/ml;
d <sub>10</sub> - <i>p</i> -xylene	(1.0 ± 0.02) mg/ml.

NOTE 1 Due to its volatility, it is difficult to make standard solutions of d<sub>6</sub>-benzene by weighing; it is recommended that suitable volumes (measured using micro-syringes) of d<sub>6</sub>-benzene, based on its density (0.950), are used.

Make up the following stock solution in dichloromethane (4.11):

$d_{62}$ -squalane (8.0 ± 0.20) mg/ml.

NOTE 2 The stock solutions are stable for at least six months, provided they are stored in the dark at (-18 ± 5) °C.

**4.16 Internal standards intermediate solution**, prepared as follows.

Place (2.5 ± 0.025) ml of the  $d_{62}$ -squalane stock solution in a 25 ml volumetric flask. Gently evaporate the dichloromethane until it is completely removed using nitrogen blow down. Verify the complete removal of the dichloromethane to incipient dryness.

NOTE 1 One way of verifying this is to evaporate to constant mass.

Then place (2.5 ± 0.025) ml of each of the remaining individual standard stock solutions (4.15) into the volumetric flask, ensuring that the  $d_6$ -benzene stock solution is added last, and make up to the graduation mark with acetone (4.12).

NOTE 2 The  $d_6$ -benzene stock solution is added last in order to minimize any potential evaporative losses of this standard.

NOTE 3 This solution is stable for at least six months provided it is stored in the dark at (-18 ± 5) °C.

**4.17 Internal standards GC column test solution**, prepared as follows.

Add (200 ± 5) µl of the internal standards intermediate solution (4.16) to (8 ± 0.5) ml of dichloromethane (4.14) in a 10 ml volumetric flask, then make up to the graduation mark with dichloromethane (4.11).

NOTE 1 To avoid potential losses of the most volatile internal standard ( $d_6$ -benzene), it is recommended that a syringe, fitted with a needle of sufficient length to allow the tip to be introduced below the meniscus of the dichloromethane prior to expelling the syringe contents, is used.

NOTE 2 This solution should be renewed every three months or sooner if, during its use, an indication is obtained that the concentrations of any of the internal standards have changed.

**4.18 Internal standards spiking solution**, prepared as follows.

Add (1.00 ± 0.01) ml of the internal standards intermediate solution (4.16) to (8 ± 0.5) ml acetone (4.15) in a 10 ml volumetric flask, then make up to the graduation mark with acetone (4.12).

NOTE This solution should be renewed every three months or sooner if, during its use, any indication is obtained that the concentrations of any of the internal standards have changed.

**4.19 Sodium sulfate (anhydrous)**, prepared as follows.

Remove any organic contaminants by heating at (500 ± 50) °C for ≥ 4 h, and store so that rehydration is minimized and re-contamination cannot occur.

## 5 Apparatus

**5.1 Vessels and containers**, constructed of a material such as glass or polytetrafluoroethylene (PTFE) that is inert under the specified test conditions.

**5.2 Cleaning**, in accordance with either the following procedure or with an alternative procedure demonstrated to be equally effective in removing all detectable traces of organic compounds from the apparatus.

Laboratory glassware shall be cleaned by washing with a biodegradable laboratory detergent specially designed for the removal of organic materials, followed by rinsing with hydrochloric acid solution (4.6) or chromic acid (4.9) and finally by thoroughly rinsing with reagent water (4.2).

NOTE Hydrochloric acid (4.4) should not be used to clean any stainless steel apparatus and equipment.

**5.3 1 litre borosilicate glass bottles**, of nominal capacity 1 l, fitted with either ground-glass stoppers or screw-top caps with PTFE or PTFE-faced liners.

**5.4 Concentration apparatus**, which is specifically designed to allow the solvent extract (2.11) to be reduced in volume from 200 ml to 50-500 µl.

NOTE Various commercial equipment, such as Kuderna-Danish or equivalent concentration apparatus, might be suitable. However, during this operation (which may proceed in several steps), it is essential that losses of volatile compounds are minimized. The response of the most volatile internal standard ( $d_6$ -benzene) should be checked to ensure that losses of this compound in the concentration step do not exceed 50 %. One method of checking for losses is given in D.2.

## 5.5 Instrumental

**5.5.1 Capillary gas chromatograph**, with temperature gradient facility interfaced to a mass spectrometer (5.5.4).

**5.5.2 GC capillary column**, fused silica having a length of at least 50 m, with an internal diameter of 0.25 mm or 0.32 mm, coated with a non-polar bonded phase which performs equivalently to dimethylsilicone gum (e.g. DB-1 or BP-1).

NOTE Other column types capable of giving equivalent or better performance characteristics in this test may be used. Suitable validation data should be produced to justify the substitution.

**5.5.3 Carrier gas (for GCMS system)**, helium (99.999 % purity, or better).

**5.5.4 Mass spectrometer**, which is capable of operating in the electron impact ionization mode covering the  $m/z$  range 20-650 provided that the mass spectrometric resolution (2.9) is sufficient to allow unit mass resolution at the highest mass recorded with a scan cycle of  $\leq 1$  s.

**5.5.5 Mass spectrometry data system**, which is capable of acquiring data from the mass spectrometer under the conditions in 5.5.4, and which can produce total ion current (TIC) chromatograms, background-subtracted averaged mass spectra and TIC peak areas. It shall also be capable of producing hard-copy outputs of TIC chromatograms and mass spectra.

**5.5.6 Mass spectral library**.

NOTE If a mass spectral library is not available on the mass spectrometry data system (5.5.5) alternative hard-copy documents shall be available. Examples of alternative hard-copy documents are the *Eight Peak Index of Mass Spectra* [2] or the *Registry of Mass Spectral Data* [3].

## 6 Leachate

NOTE The leachates for analysis may be prepared in accordance with Annex A or the specific requirements of the National Regulator.

### 6.1 Storage of test sample leachates

Start the analysis of leachate samples as soon as possible following collection. If necessary, store the leachate samples in the absence of light at  $(4 \pm 2)$  °C for a maximum of 48 h before solvent extraction is undertaken.

### 6.2 Procedural blank tests

Carry out a blank test procedure with each batch of test samples using the same test conditions (test water, test temperature, leaching periods, type of test vessel, stoppers, etc.) as specified for the test samples (Annex A) but omitting the test sample(s).

When only glass stoppers or stainless steel plates are used to seal pipe test pieces, a glass container is suitable for the procedural blank; when other articles, such as stoppers, connectors or sealants are used (e.g. PTFE, silicone sealant, etc.) include these in the procedural blank at the same test surface area to volume (S/V) ratio as the exposure in the test containers.

## 7 Method of analysis

### 7.1 Extraction procedure

WARNING During the solvent extraction step, excess pressure (which can build up in the stoppered separating funnel) should be dissipated via the separating funnel tap when the separating funnel is inverted. As dichloromethane vapour is hazardous, dissipation of pressure should be undertaken with the separating funnel in a fume hood.

NOTE If any leachates have been prepared using chlorinated water the residual chlorine should be neutralized by the addition of ascorbic acid solution (4.13).

Transfer  $(1 \pm 0.01)$  l of the leachate sample to a 2 l separating funnel.

Add  $(100 \pm 2)$   $\mu$ l of the internal standards spiking solution (4.18) into the sample using a syringe, ensuring that the tip of the syringe needle is below the surface of the sample. Insert the stopper and swirl the contents of the separating funnel to mix.

Check the pH of the sample and adjust to  $(2 \pm 0.2)$ , if necessary, by dropwise addition of either sulfuric acid solution (4.8) or sodium hydroxide solution (4.10) as appropriate.

Add dichloromethane ( $100 \pm 5$ ) ml (4.11) to the spiked pH adjusted sample in the separating funnel and insert the stopper. Shake the separating funnel for a total of  $3 \text{ min} \pm 20 \text{ s}$ . Remove the dichloromethane (lower layer) into a flask (capacity at least 250 ml). Add a further ( $100 \pm 5$ ) ml of dichloromethane to the separating funnel and repeat the extraction step. Add the second aliquot of dichloromethane to the flask in which the initial solvent extract is stored, so that the two extracts are combined.

Dry this combined solvent extract, then transfer it to the apparatus to be used for concentration of the extract and reduce it to a small volume ( $100\text{-}500 \mu\text{l}$ ). Store the concentrated extract in a freezer at  $(-18 \pm 5) ^\circ\text{C}$  or below until the GCMS analysis is carried out.

NOTE 1 Do not shake the contents of the separating funnel vigorously following addition of the internal standards spiking solution; doing so (in the absence of the extracting solvent, which is added later) will result in losses of the more volatile internal standards.

NOTE 2 Various methods might be suitable for drying solvent extracts, e.g. freezing or addition of small amounts of sodium sulfate (4.19). Any of these may be used provided that they do not affect adversely the performance of this method.

## 7.2 GCMS analysis

WARNING GCMS systems typically operate from a nominal mains voltage (220-240 V AC; exceptionally, some operate from a “3-phase” 415 V AC supply). However, certain parts or components of some mass spectrometers (which utilize a magnetic field for mass resolution) could be at a very high electrical potential (up to 8 kV) relative to earth; other mass spectrometers utilize radio-frequency radiation and DC voltages for mass separation. Due care is necessary in the operation of GCMS systems.

### 7.2.1 Mass spectrometer operating parameters

Follow the manufacturer’s instructions for the mass spectrometer to set the following parameters:

Ionization mode:	electron impact (EI);
Electron energy:	70 eV;
Mass range:	to include 20-650 amu;
Scan speed:	$\geq 1$ scan per second;
Scan mode:	repetitive.

### 7.2.2 Setting up the mass spectrometry data system

Follow the manufacturer’s instructions relating to optimizing the performance and sensitivity of the mass spectrometer, mass calibration and data acquisition and processing.

### 7.2.3 Initial tuning and mass calibration of the mass spectrometer

Follow the manufacturer’s instructions. All of the major reference peaks in the mass range covered in the calibration table held on the MS data system shall be found in the scan(s) used for calibration purposes.

NOTE Major reference peaks are those having an intensity  $>5\%$  of that of the base peak (which by convention is assigned an intensity of 100 %) of the calibrant used.

### 7.2.4 Setting up the GCMS system

Install the GC column according to the manufacturers’ instructions and verify its performance (e.g. in terms of separation number and adsorption) against the column performance data supplied by the manufacturer.

NOTE Proprietary standard solutions are available for this purpose (D.4).

Provided the general performance of the column is satisfactory, use the internal standards GC column test solution (4.17) to establish the initial performance of the column for the internal standards. Use the same GC temperature program for this purpose as that used for the GCMS analysis of the concentrated solvent extracts (8.1).

Ensure the temperature programming rate does not exceed  $12 ^\circ\text{C}/\text{min}$  at any time.

Ensure that all of the internal standards are detected on the TIC chromatogram.

Ensure the  $d_6$ -benzene is separated from the solvent peak and ensure the retention time of  $d_{62}$ -squalane is between 35 min and 45 min.

Ensure that the asymmetry factors,  $A_s$ , (2.2) for the peaks obtained for  $d_5$ -phenol and  $d_8$ -naphthalene are within the range 0.67 to 2.0. If this requirement is not met, investigate the cause and correct before continuing with the analysis. If necessary, install a new GC column.

Adjust the sensitivity of the mass spectrometer so that the mass spectra obtained for the internal standards present at the highest level (16 ng/ $\mu$ l) in the internal standards GC column test solution are not saturated.

Inspect the mass spectra obtained from the GCMS system performance test to ensure that they correspond closely to mass spectra previously acquired for these internal standards on the same GCMS system under identical operating conditions. Ensure that the  $m/z$  value of the base peak is consistent, and that the intensities of all peaks having an intensity >10 % of the base peak do not vary by more than 30 % of their intensity when compared to previously acquired spectra.

If the internal standards GC column test solution has not previously been analysed, analyse it once a day on the GCMS system on five separate days to obtain typical spectra of the internal standards.

Check the mass spectrometer mass calibration by inspecting the high mass ions ( $m/z > 300$ ) in the mass spectra for  $d_{62}$ -squalane to ensure that they are correctly mass measured. If this is not the case, recalibrate the mass spectrometer before continuing with the analysis.

**NOTE** The requirements for the GCMS GC run-program can be complied with by using a GC column of length 50 m to 60 m with an internal diameter of 0.32 mm, coated with a bonded phase equivalent to OV-1, an initial temperature of 30 °C for 4 min, linearly programmed at 8 °C/min to a final temperature of 300 °C and maintaining this for 20 min. Other conditions could also be suitable.

#### **7.2.5 GCMS operating conditions for analysis of solvent extracts**

Analyse concentrated solvent extracts using identical conditions to those used for checking the performance of the GCMS system using the internal standards GC column test solution.

Check the performance of the GCMS system at the end of every batch of concentrated solvent extracts run, or after every sixth concentrated solvent extract if batch sizes are greater than six.

Check the criteria in 7.2.4 to ensure that the performance of the system has not deteriorated. If the system is not in accordance with any of 7.2.4, stop the analysis, investigate and correct the cause of the failure before continuing with the analysis.

#### **7.2.6 Production of required outputs from the GCMS data system**

Ensure the following outputs are obtained for each of the GCMS runs carried out on concentrated solvent extracts:

- a hard copy of the TIC trace (covering the mass range scanned);

**NOTE** If a solvent delay is included as part of the data acquisition, the TIC trace will not include a peak for the solvent; this is acceptable.

- the retention times correct to  $\pm 1$  s, or the GCMS data system scan number, of the peak maximum of every peak detected on the TIC chromatogram, including the internal standards;
- the peak areas of every detected peak, including the internal standards;
- hard copies of a mass spectrum obtained for each of the compounds detected which are considered to originate from the sample; this shall be the best spectrum obtainable, normally obtained by background subtraction and averaging of several mass spectra.

**NOTE** Compounds detected which are not considered to arise from the sample or which are not internal standards, are included in the above requirements. However, an indication should be given as to which of the compounds detected fall into this category, along with their probable origin, e.g. contaminants in the solvent used for the solvent extraction, or compounds present in the test water.

## 8 Expression of results

### 8.1 Reporting of results

Tabulate the results from the GCMS analysis and include, for every peak detected on the TIC chromatogram, provided its peak area exceeds 50 % of that of  $d_8$ -naphthalene:

- the retention time or scan number;
- its identity;
- its estimated concentration (expressed in  $\mu\text{g/l}$ );
- the internal standard used for quantification;
- its probable origin.

NOTE If the peak for  $d_8$ -naphthalene is obscured, the peak for  $d_{34}$ -hexadecane may be used as an alternative.

### 8.2 Identification of compounds detected

Use three categories to define the confidence level associated with the identities of the detected compounds, as follows.

- A positive identification (P) indicates that the mass spectrum and GC retention time are the same as those obtained from a pure standard of the compound run under the identical GCMS conditions on the GCMS system used to analyse the concentrated solvent extract.
- A tentative identification (T) indicates that a possible identity has been obtained either from computerized library searching of a mass spectral data base, or from manual searching of a printed mass spectral database, or by interpretation from first principles by a mass spectroscopist. However, a pure standard has either not been run under identical GCMS conditions on the GCMS system used to analyse the concentrated solvent extract, or is not available.
- An unknown (U) is any compound not covered by either of the above categories. The four most intense peaks in the mass spectrum, in decreasing order of intensity, with the base (100 %) peak being emphasized by underlining (e.g. 147, 43, 71, 91), should be noted in the tabulation of results together with the retention time or scan number.

NOTE Further information on identification can be found in Annex C.

### 8.3 Quantification of compounds detected

Quantify each detected compound by comparing its response to the nearest internal standard (in terms of GC retention time) present at 2  $\mu\text{g/l}$  or 8  $\mu\text{g/l}$ , with the exception of  $d_5$ -phenol, which is not used for quantification.

Use the following equation to provide the concentration of a compound D of each compound detected in a leachate sample:

$$[D] = \frac{P_D \times I}{P_S}$$

where

- [D] is the concentration of a compound D (in  $\mu\text{g/l}$ );  
 $P_D$  is the peak area of a compound D;  
 $P_S$  is the peak area of the internal standard;  
 $I$  is the internal standard concentration (in  $\mu\text{g/l}$ ).

Make no attempt to adjust [D] for extraction efficiency.

## 8.4 Quality assurance (QA) and quality control (QC) procedures

### 8.4.1 *The mass calibration of the mass spectrometer*

Verify on each occasion that a batch of concentrated solvent extracts is analysed. Use the calibrant normally used for mass calibration for this purpose. Recalibrate the mass spectrometer if any of the calibrant masses are incorrectly assigned.

### 8.4.2 *The performance of the GCMS system*

Check the performance of the GCMS system on each occasion that a batch of concentrated solvent extracts is to be run by analysing the internal standards GC column test solution (4.17). Compare the response (peak area) obtained for each internal standard to that obtained when setting up the GCMS system (7.2.4). Provided that the peak areas are within 30 %, and the asymmetry factors are in accordance with 7.2.4, consider the performance acceptable.

### 8.4.3 *The performance of the method*

Consider the performance of the method acceptable provided the following criteria are satisfied.

- All of the internal standards are detected in the GCMS TIC chromatogram.
- The recoveries of the internal standards  $d_8$ -naphthalene,  $d_{10}$ -phenanthrene and  $d_{62}$ -squalane are >50 %.

NOTE 1 The absence of any of the internal standards in the GCMS TIC chromatogram indicates that either the extraction step has not been carried out correctly, or the concentration of the solvent extract has not been carried out correctly, or the GCMS system is not functioning correctly.

NOTE 2 A procedure for calculating the recoveries of internal standards is given in D.3.

## 9 Test report

### 9.1 General

The test report shall include the following particulars:

- a title (e.g. "Test Report") and the date of issue of the report;
- a reference to this British Standard, i.e. BS 6920-4;
- name and address of laboratory, and location where the tests were carried out if different from the address of the laboratory;
- unique identification of the test report (such as serial number), and on each page an identification in order to ensure that the page is recognized as a part of the test report, and a clear identification of the end of the test report;
- name and address of the client placing the order;
- the name(s), function(s) and signature(s) or equivalent identification of person(s) authorizing the test report.

### 9.2 Test results

The report of the GCMS analysis undertaken on the leachates shall include the following:

- a copy of the TIC chromatograms (2.13) for the internal standards GC column test solution obtained on each analytical occasion;
- a data table listing the following for each sample and GC column test mix:
  - the peak asymmetry values for  $d_5$ -phenol,  $d_8$ -naphthalene, and the percentage recoveries for  $d_8$ -naphthalene,  $d_{10}$ -phenanthrene and  $d_{62}$ -squalane;
- limits of detection for the deuterated internal standards and a description of the procedures used to obtain them;
- description and results of the method validation (method performance) for the GCMS method;
- results from the GCMS examination of each solvent extract reported in a tabular format, together with a copy of the TIC chromatogram for each solvent extract;

— data tables listing the following:

- 1) all peaks detected, including internal standards which were spiked at concentrations equivalent to 1 µg/l or greater in the leachates;
- 2) those peaks considered not to originate from the product being tested with an indication of their possible origins;
- 3) the scan number or retention time of each peak listed and the identity of the compound;
- 4) the estimated concentration of each peak considered to originate from the test material in µg/l, together with the internal standard used to derive this estimate;
- 5) those peaks which cannot be identified reported as “unknowns” with their four major ions (in decreasing order of intensity);
- 6) a print-out (or copy) of the mass spectrum for each compound detected which is considered to originate from the product being tested;
- 7) a description of the basis on which peaks are identified (8.2).

NOTE In cases where compounds detected in procedural or laboratory blanks are also detected in solvent extracts from the leachates, if the apparent concentrations in the blanks and extracts are low (<2 µg/l) and do not differ by more than 25 % of the highest concentration, the concentrations and differences are not considered significant and no concentrations should be indicated in the data tables. In cases where the apparent concentrations of such compounds are lower in a solvent extract than in the procedural or laboratory blank, no concentration should be indicated in the data tables. When the apparent concentrations of such compounds are higher in the solvent extracts than in the procedural blanks, and >2 µg/l, a “blank subtracted” concentration should be reported, i.e. the apparent concentration in the procedural or laboratory blank is subtracted from the apparent concentration in the solvent extract.

## Annex A (informative) Procedure for preparing test leachates

### A.1 Introduction

The number and duration of leaching (migration) periods, the nature of the test sample(s), the test surface area to volume ratio and the temperature for leachate preparation should be specified by the National Regulator based upon the nature of the product and its proposed use. This annex provides a typical “model” for the preparation of leachates based upon the current requirements of the National Regulator. It covers typical test sample requirements and leachate preparation conditions. Flow diagrams are included to illustrate typical sets of leachate preparation conditions for both factory-made (Figure A.1) and site-applied products (Figure A.2).

Leachates can be prepared using chlorine-free test water (A.3.2) and/or chlorinated test water (A.3.3).

### A.2 Terms and definitions

#### A.2.1

##### **product**

manufactured item, in its finished form, that comes into contact with water, including a component part of a manufactured item

#### A.2.2

##### **composite product**

product where the water contact surface is made from a material that differs from those comprising the remainder of the product

#### A.2.3

##### **test sample**

product or a part of a product, submitted for testing for suitability for use in contact with water intended for human consumption

#### A.2.4

##### **procedural blank**

test water sample for laboratory tests, known to contain negligible levels of contamination, treated in the same way as the leachate but which does not come into contact with the material tested, and analysed in the same way as the leachate

NOTE Procedural blanks are used to check for potential contamination of either leachates or solvent extracts during the whole of the procedure, from extract preparation to analysis.

### A.3 Reagents and apparatus

**A.3.1 Tap water**, obtained from a tap connected directly to a service pipe at mains pressure and having a free chlorine content of less than 0.2 mg/l.

**A.3.2 Test water**, having a conductivity of <2 mS/m, a total organic carbon content of <0.2 mg/l carbon, and free from organic contaminants which could interfere with the GCMS analysis of the extracts.

NOTE Suitable test water can be prepared by reverse osmosis, deionization or distillation.

A single batch of test water should be used for the preparation of all extracts and procedural blanks from each batch of test samples and each leaching period. If this is not possible then laboratory procedural blanks should be taken for each batch of test water.

**A.3.3 Chlorinated test water**, test water in accordance with A.3.2, having a free residual chlorine content of  $(1 \pm 0.2)$  mg/l (A.3.4). The free residual chlorine content should be determined in accordance with BS 6068-2.26.

**A.3.4 Sodium hypochlorite**, prepared from a commercial solution of sodium hypochlorite (NaOCl) and having a known concentration of about 0.1 % by mass of free chlorine.

NOTE Sodium hypochlorite solution is unstable and should be prepared on the day of use.

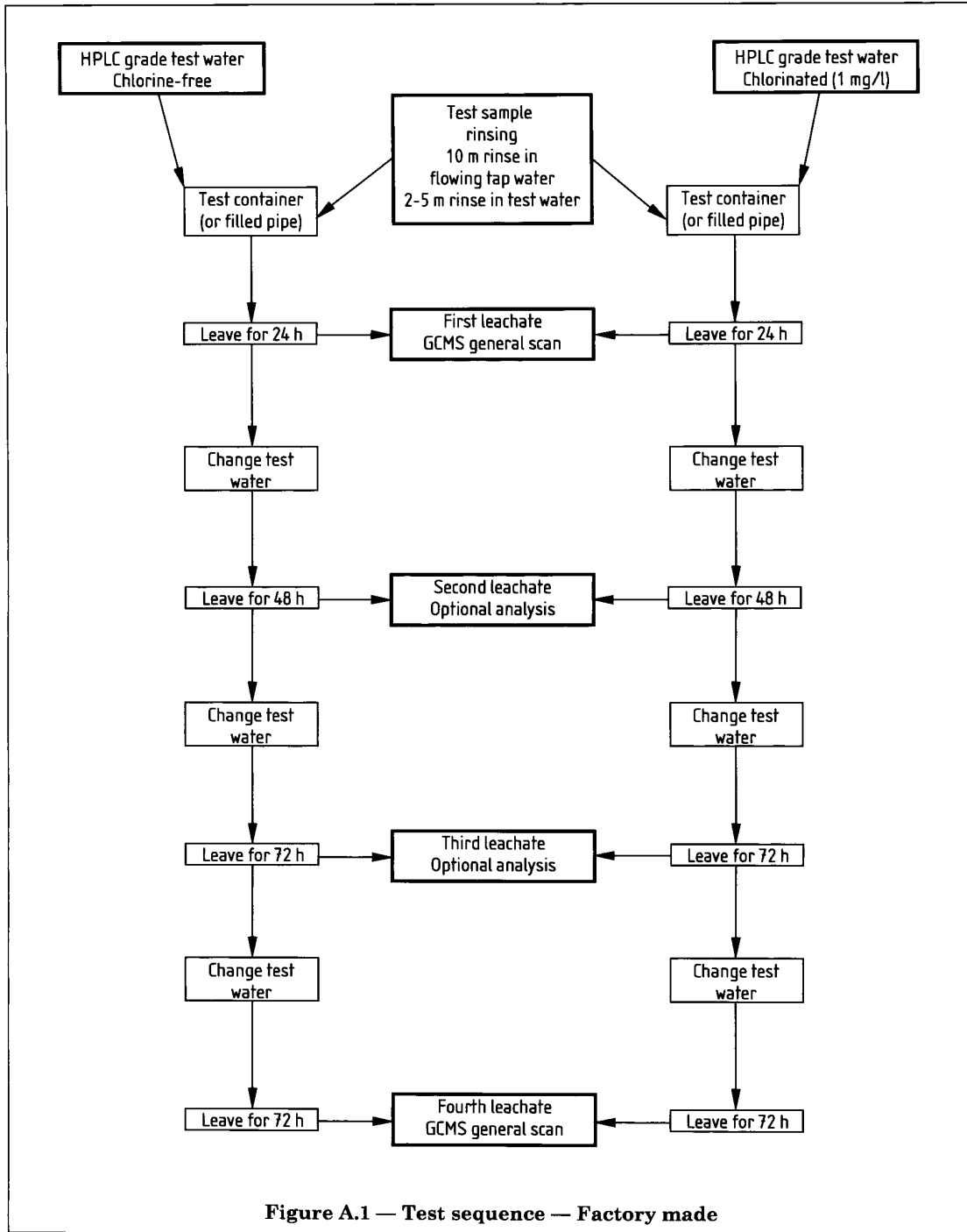

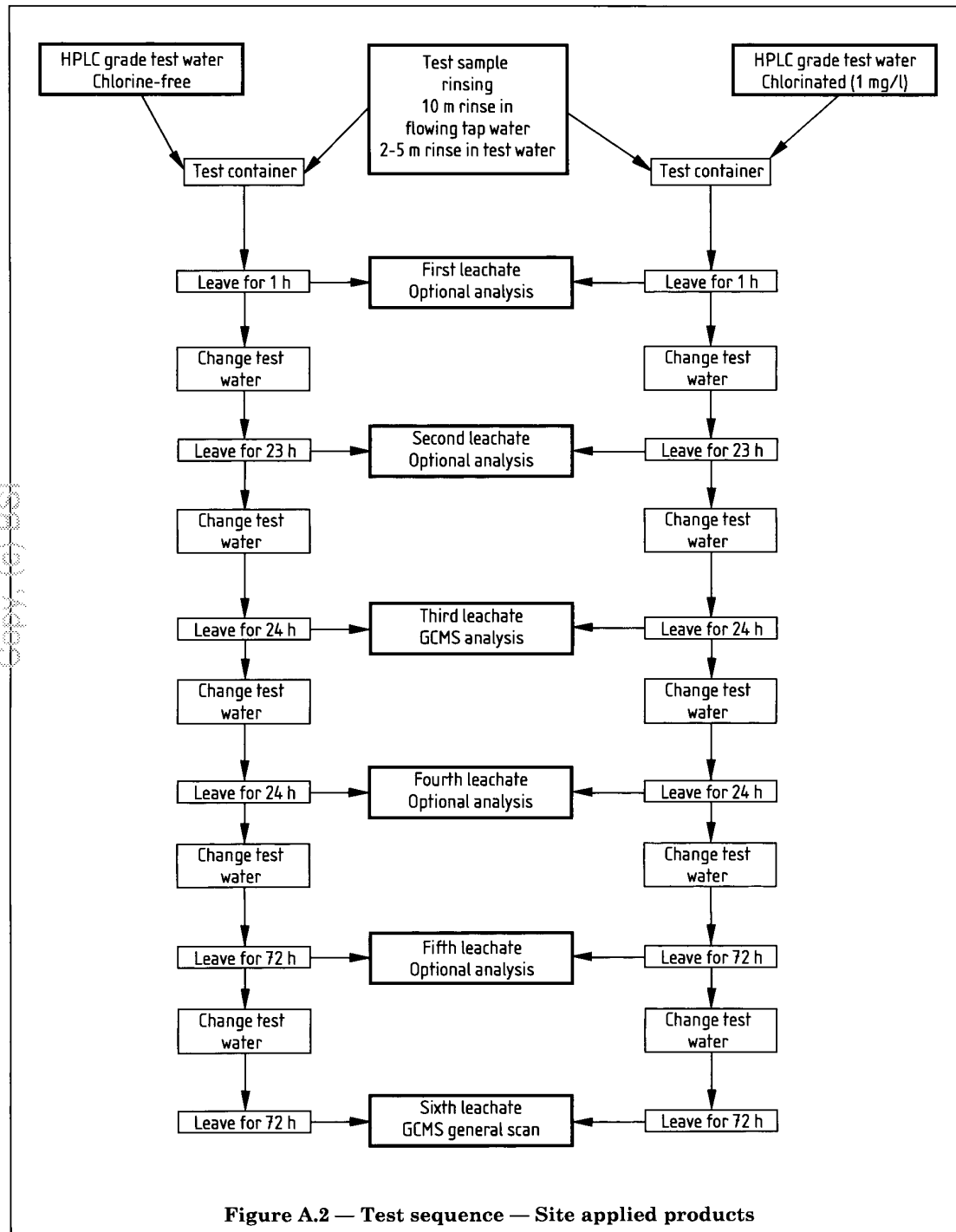

**A.3.5 Vessels and containers**, constructed of a material, such as glass or polytetrafluoroethylene (PTFE) that is inert under the specified test conditions. Cleaning should be carried out in accordance with either the following procedure or with an alternative procedure demonstrated to be equally effective in removing all detectable traces of organic compounds from the apparatus.

Laboratory glassware, as well as stainless steel and glass plates, should be cleaned by washing with a biodegradable laboratory detergent specially designed for the removal of organic materials, followed by rinsing with hydrochloric acid solution (4.4) (except for stainless steel), nitric acid solution (4.6) or chromic acid (4.9) and finally by thoroughly rinsing with reagent water (4.2).

#### A.4 Test samples

##### A.4.1 General

Whilst the test sample requirements given in BS 6920-2.1 are applicable in many cases, the National Regulator might require different types of test samples for specific applications and/or product types. It is therefore essential to seek guidance from the regulator before starting any leachate preparation.

Leachates of most products should be prepared by immersing samples of the product in test water. In the case of test pipes, however, leachates should be prepared by completely filling them with the test water.

##### A.4.2 Surface area to volume (*S/V*) ratio

The normal test surface area to volume (*S/V*) test ratio requested for this test is 1 cm<sup>2</sup> sample surface area in 1 cm<sup>3</sup> of test water (this can be expressed as 1 cm<sup>-1</sup> or 10 dm<sup>-1</sup>). This test ratio is subject to variation, however, depending upon product type and the proposed applications/uses. It is therefore essential to seek advice from the regulator before leachate preparation.

In the case of some samples, it might be impossible to achieve the specified *S/V* ratio; in this case the nearest achievable ratio should be used and this should be specified in the test report (A.6).

NOTE The *S/V* ratio used for pipe samples will be determined by the internal diameter of the pipe (A.4.3.2 and A.4.3.3).

The same *S/V* ratio should be used in tests intended to be comparable.

##### A.4.3 Specific test sample types

###### A.4.3.1 Pipes and factory applied pipe linings

The smallest diameter of the pipe for which approval is being sought should be used for the preparation of test leachates.

###### A.4.3.2 Pipes with internal diameters of <100 mm

The length of pipe used should be chosen to provide a sufficient volume of leachate for analysis.

NOTE Annex B gives details of two methods which can be used for sealing the ends of test pipe lengths. Alternatively, suitable stoppers (A.3.5 for materials) can be used to seal the ends of test pipes.

###### A.4.3.3 Pipes with internal diameters of >100 mm

For pipes made from homogeneous materials, leachates can be prepared by immersing segments of pipe in test water so as to give the required test *S/V* ratio.

For composite material pipes, or for testing pipe linings, one of the test arrangements detailed in Annex C can be used to give the specified *S/V* ratio.

NOTE If a pipe with an internal diameter of >100 mm is filled with test water, it will give an *S/V* ratio of <1 cm<sup>-1</sup>.

##### A.4.4 Cementitious products

Test samples should be prepared in accordance with 5.15 or 6.8 of BS 6920-2.1:2000. The surface area of the samples should meet the requirements of the regulator. Test samples should be preconditioned by a maximum of three 24 h sequential soak periods in contact with non-aggressive water before the leaching tests are started.

##### A.4.5 Sample storage

Test samples should be stored in the absence of light at (21 ± 4) °C and in an environment free of contamination, e.g. metal boxes or containers, or wrapped in unglazed non-pigmented tissue paper.

## A.5 Leachate preparation

### A.5.1 Pre-treatment of samples

On the same day as testing is to start, the test samples should be rinsed in flowing tap water (A.3.1) for 10 min, and then rinsed with the appropriate test water (A.3.2 or A.3.3) for 2 min to 5 min.

### A.5.2 Leaching

The leachate preparation should be started immediately after pre-treatment of the sample (A.5.1).

Test containers or test pipe lengths should be fully filled with the appropriate test water (A.3.2 and/or A.3.3) so that there is no unfilled headspace.

Other sample types should be fully immersed in test water (A.3.2 and/or A.3.3) for the appropriate leaching periods at the appropriate test temperature. The number and duration of the leaching periods will be specified by the National Regulator. (See note 2.)

At the end of each leaching period, the test leachates should be collected for analysis (A.5.3).

NOTE 1 Thin layer chromatography tanks (volume 3.5 l to 4 l) with glass lids are suitable containers for use in the preparation of leachates.

NOTE 2 In many cases, the National Regulator might specify collection and analysis of 48 h and/or 72 h leachates in addition to the 24 h leachates. In this case, the leaching procedure is repeated using fresh test water for each leaching period. 48 h leachates are those produced by re-immersion of the test material for  $(48 \pm 2)$  h at  $(23 \pm 2)$  °C in fresh test water at the end of the 24 h (first) leaching period. Similarly, two 72 h leachates are those produced by re-immersion of the test material for two sequential  $(72 \pm 3)$  h periods at  $(23 \pm 2)$  °C in fresh test water at the end of the 48 h (second) leaching period.

### A.5.3 Collection of leachates

When collecting samples of leachate, rinse the glass sample bottle (5.3) with a portion of the leachate before collecting the sample for analysis. Completely fill the bottle so that there is no headspace above the sample.

NOTE This is to prevent the loss of volatile components from the sample.

When collecting samples of leachates produced using chlorinated test water (A.3.3), add 2 ml of ascorbic acid solution (4.13) to the sampling bottle after rinsing the bottle with a portion of the leachate, but before collecting the sample as above.

NOTE For leachate samples produced using test water (A.3.2), there is no requirement to add ascorbic acid.

## A.6 Test report

### A.6.1 General

In addition to the requirements of clause 9, the test report should include:

- description and unambiguous identification of the item(s) tested as set out below;
- reference to any sampling or sample preparation procedures used by the laboratory, or other bodies and where appropriate, chain of custody details;
- the date of receipt of test item(s) and date(s) of performance of the tests undertaken;
- deviations from, additions to or exclusions from the test method;
- full details of leachate preparation, including surface area to volume test ratio used, temperature of leaching, number and duration of leaching periods, type of test water(s) used; and
- full details of the test results obtained on the leachates; these should meet the minimum requirements set out in 9.2;

**A.6.2 All test product samples**

For all product samples, the test report should include:

- the general composition of the product;
- the trade name and designation of the product;
- the nature of the material, e.g. nitrile rubber, polyethylene;
- date(s) of manufacture (if known);
- the name and address of the manufacturer of the product;
- the organization submitting the product for testing;
- the organization responsible for preparing the samples (if different);
- description of the sampling procedure (if known);
- condition on receipt by the test laboratory, including packaging in contact with the test product;
- the conditions of storage between sample receipt and the start of testing;
- a comprehensive description of the test sample including material type, colour, shape/form, dimensions (mm), appearance, opacity and component type (if appropriate);
- the surface area of one example of the product exposed to the test water calculated from the actual dimensions;
- the number of examples of the product required to give the required surface area for one test (cm<sup>2</sup>);
- the volume of test water (in litres) used for a single test; and
- the surface area to volume (S/V) test ratio (dm<sup>-1</sup>).

**A.6.3 Cementitious products**

For cementitious products, the test report should include:

- details of any preconditioning given, including the aggressivity index of the preconditioning water, together with the pH values of each of the sequential preconditioning leachates; and
- for admixtures, the volume of admixture added to a specified mass of cement.

**A.6.4 Factory applied products in the form of coatings where test samples were prepared by the manufacturer or supplier**

For factory applied products in the form of coatings where test samples were prepared by the manufacturer or supplier, the test report should include:

- the method of preparation of test sample, if known, e.g. number and thickness of coats applied (including primers);
- the method of application of the product;
- the ambient temperature at the time of preparation;
- the date of preparation of the sample;
- cure conditions;
- the substrate onto which the product has been applied; and
- whether the product was prepared in accordance with the application instructions.

**A.6.5 Factory applied products used in assembly, e.g. greases, lubricants, solvent cements etc. where test samples were prepared by the test laboratory in accordance with section 2.1 of BS 6920**

For factory applied products used in assembly, e.g. greases, lubricants, solvent cements etc. where test samples were prepared by the test laboratory in accordance with section 2.1 of BS 6920, the test report should include:

- method of preparation of test sample, if known, e.g. whether the sample was prepared in accordance with the application instructions; and
- the cure conditions, if any, used before testing started.

**A.6.6 Site applied products**

For site applied products, the test report should include:

- typical uses of the product;
- the batch number(s) of site applied products (and other products, when known). If this information is not available this should be stated in the final report;
- realistic cure conditions achievable on site; in the case of cure temperatures above either 7 °C or 12 °C (as appropriate), how these will be achieved reliably on site;
- the method of preparation of test sample; whether the sample was prepared in accordance with the user instructions, plus the number and nature of coats applied, cure conditions, etc.;
- full details of sample preparation, including component mix ratios (if appropriate), time and temperature of cure, and sample description. If non-standard cure conditions have been used for the product then a statement highlighting these conditions should be included; and
- for samples prepared at a different location to the test laboratory, the following additional information should be included:
  - location;
  - description of equipment used and the area where the samples were prepared; and
  - full description of sample preparation, mixing ratios and batch numbers;
  - chain of custody of the test samples, method of transfer to the test laboratory and temperature profiles of the test samples during transport to the laboratory for final curing;
  - time and temperature of final curing.

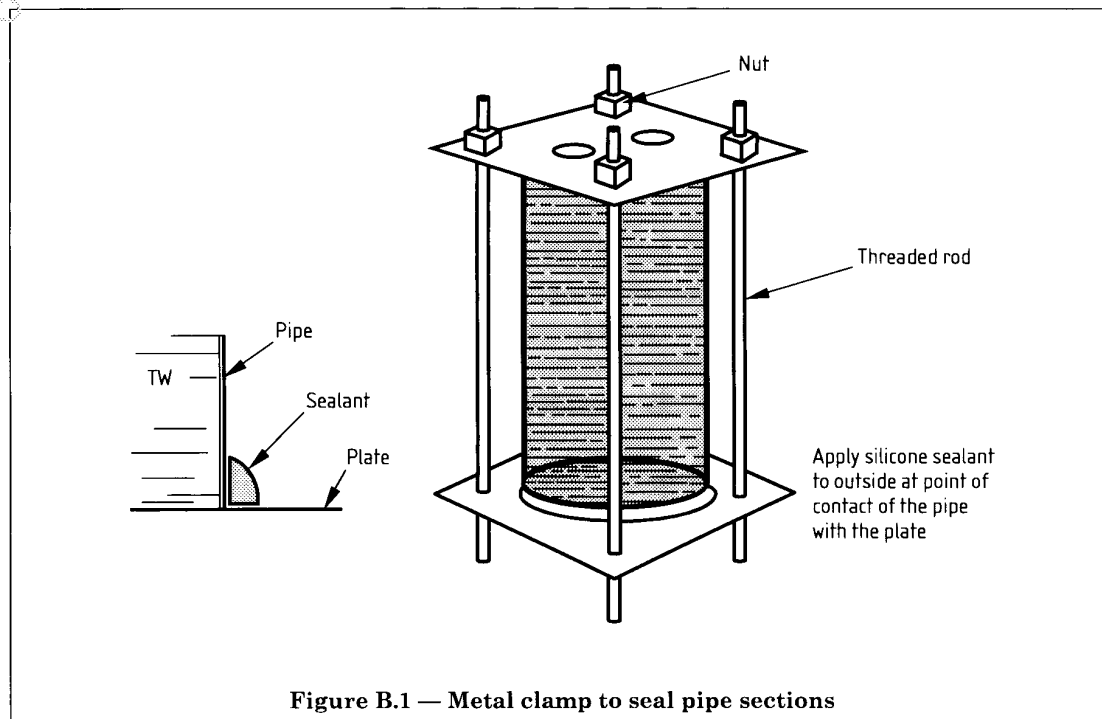
**Annex B (informative)****Methods for sealing the ends of pipe sections****B.1 Sealing using metal plate clamps (see Figure B.1)**

**Figure B.1 — Metal clamp to seal pipe sections**

**B.1.1 Equipment****B.1.1.1 Stainless steel plates**

Square plates should be made from polished stainless steel. The length of each side of the plates should be at least 10 mm to 20 mm greater than the outside diameter of the pipe. The plates should be of sufficient thickness to prevent them bending when clamped under pressure on to the ends of the pipe sections, and should be drilled to accept four threaded connecting rods.

The top plate should have two stoppered openings to permit filling and emptying. Clean the plates (A.3.5). Rinse the plates in tap water (A.3.1), once in laboratory water complying with grade 3 of BS EN ISO 3696 and finally in the test water (A.3.2). Drain and air dry. Only clean sufficient plates for immediate use; stored plates should be recleaned, using this procedure, before use.

**B.1.1.2 Pipe section**

Ensure that the end of the pipe section to be sealed has been either turned true or ground flat.

**B.1.1.3 Silicone sealant**

The silicone sealant should be a low-toxicity aquarium grade.

**B.1.2 Unit assembly**

Place the pipe section with a dry and visually clean end onto the centre of a stainless steel plate. Place the top plate (with two openings over the top of the pipe section) and then insert and tighten the connecting bolts to give a water tight seal between the bottom plate and the pipe section.

NOTE To prevent leaks, a small amount of silicone sealant may be used on the outside of the bottom joint between the test piece and plate (B.1.1.3).

**B.2 Sealing using glass plates****B.2.1 Apparatus****B.2.1.1 Glass plates**

Square glass plates should be made from float glass free from any visually detectable imperfections. The length of each side of the plates should be at least 10 mm to 20 mm greater than the outside diameter of the pipe.

Clean the plates (A.3.5). Rinse the plates in tap water (A.3.1), once in laboratory water conforming with grade 3 of BS EN ISO 3696 and finally in the test water (A.3.2). Drain and air dry. Only clean sufficient plates for immediate use. Stored plates should be recleaned before use, using the procedure stated above.

**B.2.1.2 Pipe section**

Ensure that the end of the pipe section to be sealed has been either turned true or ground flat. Confirm this by standing the pipe with this end uppermost, moisten the prepared end with test water and then place a suitably sized glass plate over this end.

Look through the glass plate and examine the surface of the end of the pipe for any evidence of irregularity or voids.

NOTE This sealing method is unsuitable for use with pipe sections which show irregularities or voids in the cut ends.

**B.2.1.3 Epoxy adhesive**

A low viscosity commercial 2-part adhesive should be used.

### **B.2.2 Unit assembly**

Ensure the end of the pipe section is dry and visually clean. Place the pipe section onto the centre of the glass plate.

Prepare a small amount of the epoxy resin following the manufacturer's instructions and then gently spread a bead of this around the outside of the pipe/glass joint.

**NOTE** If there is any relative movement between the pipe section and the glass plate during this operation, it is likely that the resin will be in contact with the test water and therefore render the assembly unsuitable for use.

Leave the assembly to cure undisturbed in accordance with the adhesive manufacturer's instructions.

Turn the assembled unit upside down and examine the joint through the glass. If any of the resin has penetrated by capillarity, or through voids, to the inner surface of the pipe section, this assembly is unsuitable for testing purposes.

## **Annex C (informative)**

### **Suitable methods for preparing extracts from large diameter pipes**

Figure C.1 and Figure C.2 show suitable methods for obtaining extracts from lengths or segments of large diameter pipes (>100 mm diameter).

Seal test rigs by mechanical means only (clamps or bolts). If this cannot be achieved then use PTFE film/tape or a suitable sealant on the *outside* (non-water contact side) of the test piece.

Completely fill the test rigs with test water (A.3.2 or A.3.3) and seal them, e.g. with suitable stoppers.

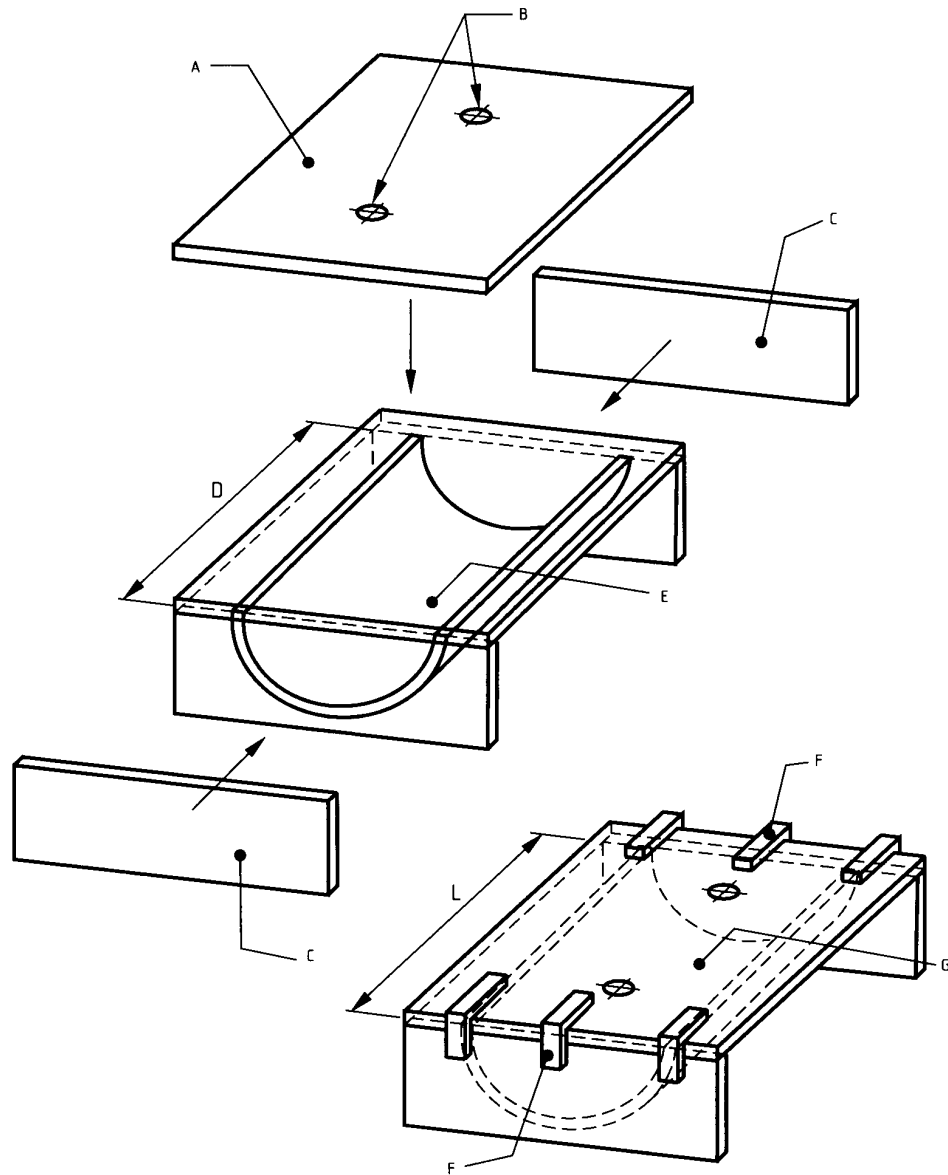

- A Cover of glass or stainless steel
- B Filling and/or air-escape hole
- C End piece of stainless steel
- D Length of test piece =  $L$
- E Test piece
- F Clamps or bolts
- G Test piece completely filled with test liquid

Figure C.1 — Test arrangement 1

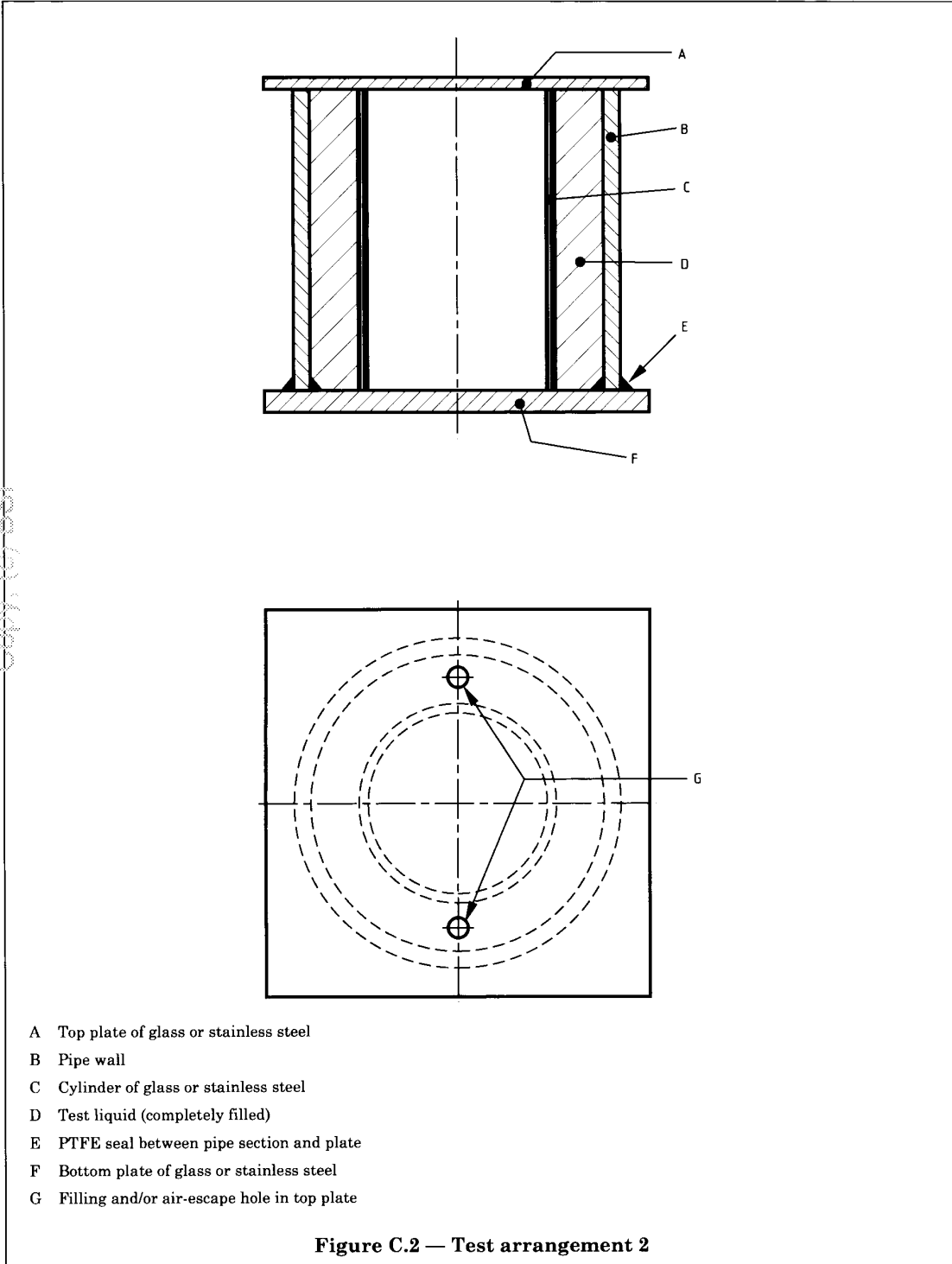

## Annex D (informative) Additional procedural details

### D.1 Outline of general approach for identification of compounds detected

The data acquired during the GCMS run for each solvent extract is normally stored on the mass spectrometry data system as a discrete data file which may be inspected either while the run is proceeding or after the run has been completed.

The data is usually initially displayed on a data system visual display unit (VDU) as a total ion current (TIC) chromatogram or reconstructed ion chromatogram (RIC). Each compound detected should appear as a peak on the TIC or RIC trace, and the mass spectra produced by each compound can be displayed on the VDU using the appropriate commands.

Normally, the mass spectrum initially chosen for display will be that produced when the concentration of the compound of interest is at its maximum (i.e. at the top of the peak). However, if it is suspected that the eluting peak is a mixture (i.e. two or more compounds are not satisfactorily separated by the GC column), or if the mass spectrum is saturated (due to the dynamic range of the mass spectrometer being exceeded), other spectra may be chosen for display.

An obvious indication that a mass spectrum is saturated, or overloaded, is provided by the presence of more than one peak in a mass spectrum at an intensity of 100 %. Mass spectra from scans obtained before or after the intensity maximizes should be inspected to obtain a representative mass spectrum for the compound of interest, although if a single spectrum is chosen it should be ascertained that it is not distorted (skewed).

Mass spectra may be averaged across a peak (provided it is considered that the peak is due to a single compound) to minimize any distortion of the spectra which can occur if the concentration of a compound entering the mass spectrometer changes significantly during the course of a single mass spectrometer scan. This can occur when a GC peak is very sharp, e.g. only 2 s to 3 s wide. However, before averaging several spectra through a peak, each spectrum should be checked to ascertain whether any are saturated; if any are, due allowance should be made when assessing the resulting averaged spectrum.

A background subtraction should also be performed, either on a mass spectrum from a single scan or on an averaged spectrum, in order to remove spurious peaks such as those produced by residual air in the mass spectrometer, or from GC column bleed.

The mass spectrum obtained for each peak detected is generally initially inspected visually. Depending on the experience of the mass spectroscopist, it might be possible to identify the compound giving rise to the spectrum without recourse to reference mass spectra held in libraries (on the data system, or in reference books).

If the mass spectrum is not visually recognized, a library search is usually carried out on the data system. It is recommended that a reverse searching procedure should be used. The closeness of the match between the unknown and the chosen library spectra is usually expressed in terms of three parameters; fit, purity and reverse fit. However, the best match chosen by the data system does not necessarily lead to the identification of the unknown, and the mass spectroscopist has to apply his/her judgement, taking into account such factors as the GC retention time, in order to decide whether the identification suggested by the computerized library search is accepted.

If there is any doubt concerning such an identification, it should be noted as a tentative identification and, if it is necessary to confirm the identification, a pure standard of the compound in question should be obtained and run on the GCMS system in order to check the mass spectrum obtained and the GC retention time. The same principles apply to potential identifications resulting from manual inspection of mass spectral reference collections in books such as *The Eight Peak Index of Mass Spectra* [2].

If it is suspected that a TIC peak is a mixture of two or more compounds, mass chromatography could be of use in deciding whether this is the case, and by careful choice of mass spectra, it may be possible to produce spectra corresponding to each co-eluting component. However, where two compounds have identical retention times, this might not be possible, and further progress is dependent on the experience of the mass spectroscopist.

It is inevitable that a significant proportion of the compounds detected in many general survey GCMS runs will only be tentatively identified, and that some will be unidentified, as the reference collections of mass spectra currently available represent a very small proportion (<10 %) of the known organic compounds that are amenable to GCMS analysis.

## D.2 Checking suitability of apparatus used for concentrating solvent extracts

It is necessary to be able to reduce the volume of the dichloromethane solvent extracts from about 200 ml down to 50 µl to 500 µl without significant losses of volatile components which might have been present in the leachate sample.

To verify that this can be satisfactorily achieved, it is recommended that a 500 µl portion of the internal standards GC column test solution (4.17) is diluted to 200 ml with dichloromethane, and the resulting solution concentrated to 500 µl, using appropriate apparatus or equipment. This concentrate should be run on the GCMS system under exactly the same conditions as used when using the GC column test standard solution for checking for satisfactory GC performance, and the TIC or RIC trace compared to a TIC or RIC trace obtained when the GC column test standard is run. Provided the loss of the most volatile internal standard, *d*<sub>6</sub>-benzene, is not more than 50 %, the technique used for the concentration of the solvent extracts is considered satisfactory.

## D.3 Procedure for calculation of recoveries of internal standards

The concentrations of the various internal standard solutions, the volume of the leachate analysed, and the volumes injected onto the GCMS system when the final volume of the concentrated solvent extract is 500 µl are such that the TIC chromatograms generated for the internal standards GC column test solution (4.17) and the concentrated extract (7.1) are directly comparable, so that the following equation can be used to calculate % recoveries:

$$R = \frac{P_e \times 100}{P_s}$$

where:

- R* is the recovery of internal standard (in %);
- P<sub>e</sub>* is the peak area of the internal standard chosen for the comparison, in extract;
- P<sub>s</sub>* is the peak area of the internal standard chosen for the comparison, in standard.

## D.4 Standard solutions for checking GC column performance

Several chromatography supply companies produce mixtures specifically designed to evaluate the performance of GC columns, in terms of parameters such as column efficiency and adsorptive or “active” sites. These are sometimes referred to as “grob mixtures”. If the GC column used is from a manufacturer who does not provide a suitable test chromatogram, the column should be evaluated before use with solvent extracts of leachates, using this type of test mixture.

## D.5 Performance testing data for this protocol

A tabulated summary of the data obtained during within-laboratory and inter-laboratory performance testing of the analytical procedures described in this part of BS 6920 is given in Table D.1 and Table D.2. Competent laboratories intending to use these procedures should be able to produce comparable data.

Table D.1 — Within-laboratory performance data for internal standards

Sample <sup>a</sup>	Data system code	Peak area									
		d <sub>6</sub> -benzene	d <sub>9</sub> -chlorobenzene	d <sub>10</sub> -p-xylene	d <sub>5</sub> -phenol	d <sub>8</sub> -naphthalene	d <sub>21</sub> -BHT <sup>b</sup>	d <sub>34</sub> -hexadecane	d <sub>10</sub> -phenanthrene	d <sub>62</sub> -squalane	
PE-TW (1)	0030S021	7 211	8 522	2 981	9 844	2 739	56 153	2 768	14 583	90 672	
PE-TW-Cl (1)	0030S031	5 588	10 633	1 815	10 635	3 700	56 423	4 668	19 328	100 599	
GRP-TW (1)	0030S041	5 754	9 923	3 885	13 097	2 753	61 581	3 160	16 134	99 354	
GRP-TW-CL (1)	0030S051	8 994	10 401	3 820	14 973	3 369	57 335	4 567	21 121	101 328	
BIT-TW (1)	0030S061	5 603	6 327	1 318	7 156	2 302	48 171	3 638	16 048	85 730	
BIT-TW-CL (1)	0030S071	6 916	11 074	2 969	9 627	4 402	57 669	4 469	16 901	54 348	
PB-TW (1)	0030S091	12 190	13 005	2 887	10 916	4 029	65 931	4 728	15 546	102 366	
PB-TW-CL (1)	0030S101	9 215	10 259	2 671	8 351	3 744	48 374	4 523	14 240	78 070	
PE-TW (2)	0030S121	6 498	9 329	3 311	7 335	3 868	53 707	3 531	14 276	85 766	
PE-TW-CL (2)	0030S131	4 665	9 183	3 188	6 197	2 929	62 658	4 435	17 728	113 155	
GRP-TW (2)	0030S141	5 766	7 986	2 087	12 357	2 531	50 362	5 212	16 965	87 439	
GRP-TW-CL (2)	0030S161	5 410	11 762	3 473	13 804	2 375	61 799	6 283	20 480	100 379	
BIT-TW (2)	0030S171	4 714	6 008	4 194	9 691	2 534	39 768	2 037	13 363	36 799	
BIT-TW-CL (2)	0030S181	5 702	9 184	3 345	14 796	2 609	47 853	3 479	15 293	54 239	
PB-TW (2)	0030S191	7 207	11 073	3 163	6 846	2 765	49 139	4 875	14 024	88 095	
PB-TW-CL (2)	0030S201	6 444	7 862	2 702	7 097	2 175	54 553	6 013	15 490	85 893	
Mean		6 742	9 533	3 038	10 170	3 052	54 467	4 274	16 345	85 265	
SD		1 955	1 890	681	2 934	695	6 882	1 125	2 311	20 579	
% RSD		29 %	20 %	22 %	29 %	23 %	13 %	26 %	14 %	24 %	

<sup>a</sup> Samples referred to as follows: PE = polyethylene; GRP = glass-reinforced polyester; BIT = bitumen lined ductile iron; PB = procedural blank; TW = test water; TW-CL = chlorinated test water; (1) = batch 1, (2) = batch 2.

<sup>b</sup> BHT = 2,6-di-*t*-butyl-4-methylphenol.

Table D.2 — Summary of variation (% RSD) for internal standards in interlaboratory performance testing<sup>a</sup>

Laboratory	Batch number	% RSD for peak areas of internal standards										
		d <sub>6</sub> -benzene	d <sub>6</sub> -chlorobenzene	d <sub>10</sub> -p-xylene	d <sub>6</sub> -phenol	d <sub>6</sub> -naphthalene	d <sub>21</sub> -BHT	d <sub>34</sub> -hexadecane	d <sub>10</sub> -phenanthrene	d <sub>67</sub> -squalane		
1	1	16	15	37	24	18	23	52	15	26		
	2	25	19	27	51	42	16	21	19	21		
2	1	30	19	26	24	21	11	19	14	19		
	2	15	20	19	35	19	14	32	15	30		
3 <sup>b</sup>	1	—	15	68	32	27	36	24	10	33		
	2	—	35	27	63	44	53	84	36	96		
4	1/2	—	10	8	12	12	14	15	9	47		

<sup>a</sup> Each laboratory analysed leachates from three samples in duplicate, together with procedural blanks. Each batch consisted of eight analyses.

<sup>b</sup> Laboratory 3 did not follow instructions regarding conditions for GC/MS analysis.

---

## Bibliography

BS 6068-2.26:1986, *Water quality — Part 2: Physical, chemical and biochemical methods — Section 2.26: Method for determination of free chlorine and total chlorine: colorimetric method using N,N-diethyl-1,4-phenylenediamine, for routine control purposes.*

BS 6920-2.1:1996, *Suitability of non-metallic products for use in contact with water intended for human consumption with regard to their effect on the quality of the water — Part 2: Methods of test — Section 2.1: Samples for testing.*

BS EN ISO 3696:1995, *Water for analytical laboratory use — Specification and test methods.*

### Other publications

[1] The Water Supply (Water Quality) Regulations 1989. Statutory Instrument 1989 No. 1147 (and amendments SI 1989 No. 1384, SI 1991 No. 1837). London: TSO.

[2] *The Eight Peak Index of Mass Spectra*, 4th Edition, 1991. ISBN 0 851 86417 1, Nottingham: The Royal Society of Chemistry.

[3] *Registry of Mass Spectral Data*, 3rd Edition, 1989. Eds. F.W. McLafferty and D.B. Stauffer. ISBN 0 471 62886 7. New York: John Wiley & Sons.

BSI  
389 Chiswick High Road  
London  
W4 4AL

---

---

## BSI — British Standards Institution

BSI is the independent national body responsible for preparing British Standards. It presents the UK view on standards in Europe and at the international level. It is incorporated by Royal Charter.

### Revisions

British Standards are updated by amendment or revision. Users of British Standards should make sure that they possess the latest amendments or editions.

It is the constant aim of BSI to improve the quality of our products and services. We would be grateful if anyone finding an inaccuracy or ambiguity while using this British Standard would inform the Secretary of the technical committee responsible, the identity of which can be found on the inside front cover. Tel: 020 8996 9000. Fax: 020 8996 7400.

BSI offers members an individual updating service called PLUS which ensures that subscribers automatically receive the latest editions of standards.

### Buying standards

Orders for all BSI, international and foreign standards publications should be addressed to Customer Services. Tel: 020 8996 9001. Fax: 020 8996 7001. Standards are also available from the BSI website at <http://www.bsi-global.com>.

In response to orders for international standards, it is BSI policy to supply the BSI implementation of those that have been published as British Standards, unless otherwise requested.

### Information on standards

BSI provides a wide range of information on national, European and international standards through its Library and its Technical Help to Exporters Service. Various BSI electronic information services are also available which give details on all its products and services. Contact the Information Centre. Tel: 020 8996 7111. Fax: 020 8996 7048.

Subscribing members of BSI are kept up to date with standards developments and receive substantial discounts on the purchase price of standards. For details of these and other benefits contact Membership Administration. Tel: 020 8996 7002. Fax: 020 8996 7001. Further information about BSI is available on the BSI website at <http://www.bsi-global.com>.

### Copyright

Copyright subsists in all BSI publications. BSI also holds the copyright, in the UK, of the publications of the international standardization bodies. Except as permitted under the Copyright, Designs and Patents Act 1988 no extract may be reproduced, stored in a retrieval system or transmitted in any form or by any means – electronic, photocopying, recording or otherwise – without prior written permission from BSI.

This does not preclude the free use, in the course of implementing the standard, of necessary details such as symbols, and size, type or grade designations. If these details are to be used for any other purpose than implementation then the prior written permission of BSI must be obtained.

If permission is granted, the terms may include royalty payments or a licensing agreement. Details and advice can be obtained from the Copyright Manager. Tel: 020 8996 7070.

---

*Draft for comments only — Not to be cited as East African Standard*