



CD/K/003:2009
ICS 13.060.20; 91.140.60

EAST AFRICAN STANDARD

Protection against pollution of potable water in water installations and general requirements of devices to prevent pollution by backflow

EAST AFRICAN COMMUNITY

Foreword

Development of the East African Standards has been necessitated by the need for harmonizing requirements governing quality of products and services in East Africa. It is envisaged that through harmonized standardization, trade barriers which are encountered when goods and services are exchanged within the Community will be removed.

In order to meet the above objectives, the EAC Partner States have enacted an East African Standardization, Quality Assurance, Metrology and Test Act, 2006 (EAC SQMT Act, 2006) to make provisions for ensuring standardization, quality assurance, metrology and testing of products produced or originating in a third country and traded in the Community in order to facilitate industrial development and trade as well as helping to protect the health and safety of society and the environment in the Community.

East African Standards are formulated in accordance with the procedures established by the East African Standards Committee. The East African Standards Committee is established under the provisions of Article 4 of the EAC SQMT Act, 2006. The Committee is composed of representatives of the National Standards Bodies in Partner States, together with the representatives from the private sectors and consumer organizations. Draft East African Standards are circulated to stakeholders through the National Standards Bodies in the Partner States. The comments received are discussed and incorporated before finalization of standards, in accordance with the procedures of the Community.

Article 15(1) of the EAC SQMT Act, 2006 provides that "Within six months of the declaration of an East African Standard, the Partner States shall adopt, without deviation from the approved text of the standard, the East African Standard as a national standard and withdraw any existing national standard with similar scope and purpose".

East African Standards are subject to review, to keep pace with technological advances. Users of the East African Standards are therefore expected to ensure that they always have the latest versions of the standards they are implementing.

© East African Community 2010 — All rights reserved*

East African Community

P O Box 1096

Arusha

Tanzania

Tel: 255 27 2504253/8

Fax: 255-27-2504481/2504255

E-Mail: eac@eachq.org

Web: www.each.int

Contents

1	Scope	1
2	Normative references.....	1
3	Terms and definitions.....	1
4	Pollution of potable water: general observations.....	3
4.1	Backflow of used water	3
4.2	Connection	3
4.3	External influences	4
4.4	Materials.....	4
4.5	Stagnation	4
4.6	Harm caused by inadequate or improper maintenance	4
5	Analysis method of the risks at the point of use and choice of protection	4
5.1	General remarks.....	4
5.2	Determination of fluid categories which are or could be in contact with potable water.....	5
5.3	Determination of the installation characteristics.....	5
5.4	Separation by single or double walls	6
5.5	Air break to drain	7
5.6	Installation matrix	7
5.7	Protection units.....	7
5.8	Matrix of the protection units appropriate to fluid categories.....	9
6	Point of use protection for equipment at the draw-off point for domestic uses	9
6.1	Choice of the protection units to be implemented.....	9
6.2	Location of the protection units.....	10
7	Point of use protection of particular equipment for non domestic uses	10
8	Protection at the connection point to the public potable water system	10
9	Air break to drain	11
	Annex A (normative) Reference list of the protection units	12
	Annex B (informative) Guide table for determining the fluid category from which protection is required	43
	Annex C (informative) Summary of the analysis method	44
	Bibliography.....	45

Introduction

The type of backflow prevention device installed has to be consistent with the hazard rating. There are various types of backflow prevention devices; those listed below are the more common.

Air gap — An air gap is the most basic protection measure where potable water can flow without any possibility of a backflow, siphon or pressurized return of used water or contaminated substance. An air gap is suitable for use in high, medium or low-hazard conditions. A simple example is the sink inlet valve or tap, with its discharge point well above the overflow level of water in the sink.

Break tank — The air gap principle is extended to create a new supply head (pressure) and, if the tank is allowed to overflow, an air gap is maintained to the water inlet. The break tank provides a separated supply system that effectively isolates the potable water supply system from a new gravity head or a source for a pumped supply. A break tank is suitable for use in high, medium or low-hazard conditions. A simple example is the float-valve controlled toilet flushing cistern.

Mechanical control valves — Mechanical control valves are subject to wear and eventual failure. An inspection and maintenance programme is usually required, with the results of the programme to be reported to the water supplier. The following are types of mechanical backflow prevention devices that are typically installed downstream of the meter or stop valve at the property boundary. (There are other types designed for special operational conditions.)

- *The dual check valve (dual CV)*. This valve is designed for use in low-hazard conditions. The device is nontestable and is typically installed in domestic or residential water services. The dual CV consists of two independently acting nonreturn valves in series, arranged to be force loaded in the closed position. Domestic or residential basic size water meters are available with a dual CV included. The combination (water meter plus dual CV) is cheaper to purchase than the two components individually.
- *The double check valve (double CV)*. This valve is designed for use in medium-hazard conditions. This is a testable device and is typically used in smaller industrial or commercial water services. The double CV consists of two independently acting nonreturn valves in series, arranged to be force loaded in the closed position. Three test taps are included on the double CV, (upstream, intermediate and downstream) to enable regular checking of the valve performance. These devices are usually designed to allow the valves to be replaced without removing the device from the pipeline assembly.
- *The double check detector assembly (DCDA)*. This assembly is also designed for use in medium-hazard conditions. This is a testable device intended for use with fire services; it allows monitoring or metering of small draw-off of water for general use within the property. The DCDA consists of a double CV or a pair of nonreturn valves, a by-pass line with isolating ball valves and test taps, water meter and secondary double CV.
- *The reduced pressure zone assembly (RPZA)*. This assembly is designed for use in high-hazard conditions. This is a testable device and is typically used in industrial water services. The RPZA consists of two independently acting nonreturn valves in series, arranged to be force loaded in the closed position, and a relief valve positioned between the nonreturn valves, force loaded to be open to the atmosphere whenever the pressure differential across the upstream nonreturn valve reduces to a specified amount. Test taps are also provided for performance checking.

In the preparation of this East African Standard, the following source was consulted extensively:

BS EN 1717:2001, *Protection against pollution of potable water in water installations and general requirements of devices to prevent pollution by backflow*

Assistance derived from this source and others inadvertently not mentioned is hereby acknowledged.

Protection against pollution of potable water in water installations and general requirements of devices to prevent pollution by backflow

1 Scope

This East African Standard deals with the means to be used to prevent the pollution of potable water inside premises and the general requirements of protection devices to avoid pollution by backflow.

The hygiene protection specifications of this standard are applicable to all the standards for systems or appliances connected to the private supply system for water intended for human consumption.

This standard specifies the minimum requirements for product standards of protection units.

The product standards are used to detail product specifications. In the absence of a product standard, this standard is used as a reference in order to draw up a specification for the products out of new development.

2 Normative references

The following referenced documents are indispensable for the application of this document. For dated references, only the edition cited applies. For undated references, the latest edition of the referenced document (including amendments) applies.

CD/K/001:2009, *Design, installation, testing and maintenance of services supplying water for domestic use within buildings and their curtilages — Specification*

3 Terms and definitions

For the purposes of this standard, the following terms and definitions apply.

3.1

air break to drain

unobstructed distance between the low point of overflow, discharge or drain of a device or installation, leading from a water apparatus, and the top point of the device which collects this water

3.2

air gap

physical break between the lowest level of the water inlet and the maximum fault level or critical level of an appliance or installation, a feed pipe, or an air inlet orifice incorporated into a hydraulic circuit

3.3

air inlet

orifice designed to admit air from the atmosphere into a hydraulic circuit

3.4

appliance, equipment

device in which the potable water is used and/or is modified e.g. water heater, chemical dosing unit, coffee-machine, WC-pan

3.5

backflow

movement of the fluid from downstream to upstream within an installation

3.6

backflow protection device

device which is intended to prevent contamination of potable water by backflow

3.7

contamination

result of rendering impure by contact or mixture, to corrupt, defile, pollute, sully, taint or infect

3.8

disconnection

break in a hydraulic circuit creating an atmospheric area between two elements, one carrying or containing potable water (upstream) and another carrying or containing another fluid (downstream)

3.9

domestic use

any use related to residential or similar dwellings

- normal use for dwellings and homes, as well as hotels, schools and offices, communal residences, etc. (for example kitchen sink, wash and hand basin, bath, shower, WC, production of hot water for sanitary purposes, domestic washing machine and dishwasher, bidet, watering of garden);
- special uses relating to similar consumers where products are used with low concentrations and presenting no danger for human health (for example authorized water conditioning, air conditioning);
- in industrial and commercial premises "domestic use" is limited to water used for those applications/appliances described under normal use in dwelling and homes (for example excludes water used for process, fire fighting, central heating or irrigation systems).

3.10

downstream

the side to which fluid flows under normal conditions

3.11

potable water system

water system located downstream of the delivery point specified by the water supply authorities or regulations

3.12

family of protection

general identification of a backflow protection device principle

3.13

fluid

all substances which can be deformed by small forces. Fluids are divided into liquids and gases

3.14

liquid levels

3.14.1

critical level

physical or piezometric level of the liquid reached in any part of the appliance 2 s after closing the water inlet, starting from maximum fault level

3.14.2

maximum operational level

In an open system, this is the maximum level of the liquid. In a pressurized system, this is the maximum piezometric height possible

3.14.3**maximum fault level**

the highest physical or piezometric level of the liquid reached in any part of the appliance when it operates continuously under fault conditions as described in product standard

3.15**LD₅₀**

quantities of substances or mixture which, given on one intake through oral and parental path, bring about within 15 days (the required time to take into account potential delayed effect) the death of 50 out of 100 treated animals

3.16**non domestic use**

all uses related to a professional activity within industry, trade, agriculture, health establishments, etc. All uses related to private and public swimming pools and public baths

3.17**overflow**

means for discharging naturally excess fluid from an appliance when it has reached a specified level

3.18**point of use**

point where water is drawn by the user either directly or by connecting an apparatus

3.19**pollution of potable water**

any degradation of the quality of potable water

3.20**protection point**

location in a hydraulic circuit where a protection unit is installed

3.21**protection unit**

device, or device in combination with other hydraulic components, which constitutes the protection against backflow

3.22**type of protection**

identified operating principle applied to a protection device belonging to a given family

3.23**upstream**

side from which fluid flows under normal conditions

4 Pollution of potable water: general observations

Water installations, described in CD/K/001:2009, due to their design or construction, shall not be liable to generate pollution of public or private potable water supply system by residual matters, harmful water or any undesirable substance.

4.1 Backflow of used water

The quality of the water distributed can be impaired when used water flows back into the potable water system.

4.2 Connection

When there is a mixing of public potable water and any other water supply, the public water supply shall be protected by an unrestricted air gap.

The non-potable or suspicious water distribution network shall be separated and the whole installation marked (for example different coloured pipes). The non-potable or suspicious water taps shall have markings with clearly visible warning signs.

4.3 External influences

Potable water cisterns, pipes and protection units shall be protected from external pollution.

No other fluid shall be conveyed in a potable water installation (gas, compressed air, ventilation conduct, vapour, chemicals, water used in heating equipment, recycled water, drainage or run-off water, waste water, etc.) than potable water.

If it is considered possible that under the prescribed operation any contaminant could enter through the protection device (for example air gap, air inlet) into the potable water installation, corresponding protection measures are to be provided.

4.4 Materials

The materials used in water installations, including the materials of protection units in contact with potable water, shall satisfy the East African Standards.

They shall be compatible with each other, with the water supplied, and with the fluids or substances that can come into contact with them.

4.5 Stagnation

A stagnation of water in the systems can result in impairment of the water quality due to a significant concentration of dissolved substances or substances in suspension or to bacterial growth.

The level of impairment depends on the materials used, the water quality, the temperature (for example pipes in boiler rooms) and the duration of stagnation.

For reasons of hygiene, it is necessary that pipe systems are flushed after periods of stagnation.

Pipes which are only used rarely or which are used for short periods shall be shut off after use and flushed before being brought back into service. Pipes that are no longer in use shall be disconnected from the potable water system.

4.6 Harm caused by inadequate or improper maintenance

Any insufficient or improper maintenance of the potable water installation including backflow protection devices can result in an impaired water quality. Regular maintenance of the protection units shall be carried out. Their proper functioning shall be checked regularly in conformity with national or local provisions.

5 Analysis method of the risks at the point of use and choice of protection

5.1 General remarks

A backflow of fluid in a potable water supply system can occur by:

- a) Back siphonage: by partial vacuum (drop in pressure) in the potable water supply system (due for example to the operation of a valve, the bursting of a pipe, the operation of a booster pump, excessive water demands in a part of the system, water taken for emergency use from a fire hydrant);
- b) pressure backflow: by a back pressure originating in a non-potable system in which the pressure exceeds the pressure in the potable water system.

Two conditions must exist in order to give rise to backflow:

- a) possible contact by a physical mixing between the potable water and another fluid;
- b) pressure difference at a given point of the installation reversing the normal direction of flow.

If a common protection to several hydraulic circuits present within a potable water system is sought, it is necessary to consider the technical parameter presenting the highest risk value in the most unfavourable fluid category to all the associated circuits.

The analysis of an existing or projected installation provides information about its characteristics and the fluid categories. The result of this analysis is fixed by a cross in the appropriate field of the installation matrix (see Table 1).

For specific installations presenting an exceptional risk, additional technical parameters may be considered. In an uncontrolled situation the worst risk shall be assumed.

5.2 Determination of fluid categories which are or could be in contact with potable water

In normal use fluids that are or can be in contact with potable water are classified in five categories as defined below.

In cases where insignificant concentrations or substantial amounts of substances are present it may be appropriate to redefine the safety measurement.

5.2.1 Category 1

Water to be used for human consumption coming directly from a potable water distribution system.

5.2.2 Category 2

Fluid presenting no human health hazard.

Fluid recognized as being fit for human consumption, including water taken from a potable water distribution system, which can have undergone a change in taste, odour, colour or temperature (heating or cooling).

5.2.3 Category 3

Fluid representing some human health hazard due to the presence of one or more harmful substances ¹⁾

5.2.4 Category 4

Fluid presenting a human health hazard due to the presence of one or more toxic or very toxic substances ¹⁾ or one or more radioactive, mutagenic or carcinogenic substances.

5.2.5 Category 5

Fluid presenting a human health hazard due to the presence of microbiological or viral elements.

5.3 Determination of the installation characteristics

5.3.1 Pressure

For each hydraulic circuit present in the apparatus, locate the desired or existing point(s) to be protected, or, failing this, the point of connection of the apparatus to the potable water network.

¹⁾ The border between Category 3 and Category 4 is in principle LD 50 = 200 mg/kg body weight in reference to the EU Directive 93/21 EEC dated April 27th, 1993.

Determine the maximal operational.

Define whether the protection point (existing or foreseen) or, failing this, the point of connection of the apparatus to the potable water network is subjected to atmospheric pressure ($p = \text{atm}$) or to a pressure exceeding atmospheric pressure ($p > \text{atm}$):

- the situation will be $p = \text{atm}$ if the protection point (existing or foreseen) or, failing this point, the point of connection of the apparatus to the potable water network is located above the maximal operational level;
- the situation will be $p > \text{atm}$ if the protection point (existing or foreseen) or, failing this point, the point of connection of the apparatus to the potable water network is located below this maximal operational level.

5.3.2 Connections

All connections are considered permanent.

5.3.3 Risk attenuation

The principle of risk attenuation is accepted only for certain facilities for domestic use listed in Clause 6 and in conformity with 3.9.

5.4 Separation by single or double walls

A single wall separator consists of a single fixed and sealed partition or casing that can be in contact with the potable water on one side, and with another fluid on the other.

A double wall separator consists of at least two fixed and sealed partitions or casings creating a neutral intermediate zone between the potable water on one side and another fluid on the other.

The intermediate zone may be designed in two ways:

- containing a gaseous fluid or an inert porous material (open cells);
- containing a fluid of Category 1, 2, 3.

5.4.1 Rules

5.4.1.1 With respect to backflow prevention

Category 2 or 3 fluids may be separated from the potable water by a single wall.

When the fluid from which potable water shall be protected against backflow is of Category 4 or 5, a single wall is not sufficient.

A double wall with a safety medium in between (liquid or gas) and an acoustical or visual alarm system is always considered to be able to separate the potable water from the second fluid.

5.4.1.2 With respect to direct consumer protection

When the fluid from which potable water shall be protected against is of Category 4 or 5 and downstream of the appliance the water is intended for sanitary or food related use, a double wall shall be required.

5.4.2 Performances of separation walls

The performances of the separation by single or double walls are described in the appropriate standards.

5.5 Air break to drain

All apparatus connected to a potable water network and including a water draining device has to be provided with an air break before its discharge to the drainage system.

This air gap shall satisfy the prescriptions described in clause 9. Otherwise the fluid in the apparatus has to be considered as fluid Category 5.

5.6 Installation matrix

Table 1 — Installation matrix

Category of fluid					
Pressure	1	2	3	4	5
p = atm					
p > atm					

By making an analysis of an installation, assessment of the fluid category from which it shall be protected, as well as its technical characteristics (see 5.3 to 5.5), the pollution risk of the potable water can be determined.

Any backflow prevention arrangement already incorporated into the apparatus or the installation shall be disregarded in the analysis.

The matrix above can be completed by inserting a cross for an existing parameter resulting in the installation matrix.

5.7 Protection units

5.7.1 Generalities

When the protection unit is represented by a symbol it shall be a hexagon shape containing the letter of the protection family and the letter of the type of protection in this family.

EXAMPLE

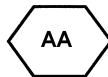

The hydraulic circuit of an installation or of an appliance connected to an installation may have several protection units; each unit comprises a protection device and the accessories needed for protection of the water and for its proper functioning, and for inspection, maintenance; (for example valve, strainer, etc.)

The protection device itself is an assembled finished product ready to be installed in a hydraulic circuit. The characteristic of families and types of protection, and the principle diagrams are given in 5.7.3.

In order to ensure that the risk coverage is fully satisfied it is necessary to correctly install the backflow protection unit.

In the selection of a backflow protection unit, it has to be verified that the device will not be affected by the attitude or angle of its installation.

The elements constituting a protection unit combined with a protection device can be:

- a stop valve;
- a test cock;
- a sampling cock;
- a strainer;
- a strainer with rinsing tap;
- an air break to drain.

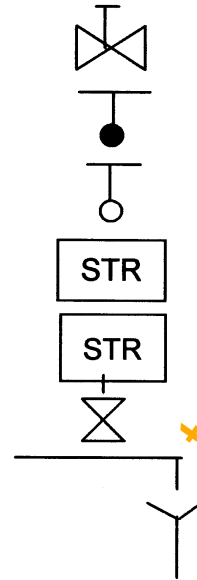

In addition, devices shall be installed in accordance with the instructions contained in technical documents supplied by the manufacturer, provided of course that this does not compromise the protection safety.

5.7.2 Functional requirements for backflow protection units

Protection units shall be so constructed that they will safely prevent backflow by back-pressure and/or by back siphonage of a contaminated fluid into a potable water system.

The degree of protection security and the method of operation of the device, i.e. either an air gap arrangement, air inlet port, or a mechanical arrangement, will depend upon the category of the contaminated fluid from which the potable water system needs to be protected.

Except for particular fields of application, backflow protection devices shall be able to operate without either modification or adjustment:

- at any pressure up to and including 1 MPa (10 bar);
- for any pressure variation up to 1 MPa (10 bar);
- when operating continuously at a temperature limited to 65 °C and at 90 °C for 1 h.

Product specifications for the protection device shall include an endurance test for its expected lifetime.

When a backflow protection device is designed with an holding back of water, it shall be fitted with a water drain port.

Internal and external parts of these devices shall be accessible for:

- inspection and test;
- replacement or repair.

On devices of DN > 50 mm it is preferable for these operations to be carried out *in situ*.

Replaceable components shall be designed so that they can only be reassembled without error in their original positions (with no risk of inversion, reversal etc.).

Elements contributing to the setting shall be fixed and not adjustable. Details are provided in the appropriate product standard.

Additional actuating devices (electric, pneumatic, etc.) are not to have a negative influence on the operation of the backflow protection function.

Materials shall be selected as described in 4.4.

5.7.3 Description of the listed protection units

See Annex A.

5.8 Matrix of the protection units appropriate to fluid categories

The suitability of each protection unit is indicated in the Table 2.

Table 2 — Matrix of the protection units appropriate to fluid categories

	Protection unit	Category of fluids				
		1	2	3	4	5
AA	Unrestricted air gap	*	•	•	•	•
AB	Air gap with overflow non-circular (unrestricted)	*	•	•	•	•
AC	Air gap with submerged feed incorporating air inlet plus overflow	*	•	•	—	—
AD	Air gap with injector	*	•	•	•	•
AF	Air gap with overflow circular (restricted)	*	•	•	•	—
AG	Air gap with overflow tested by vacuum measurement	*	•	•	—	—
BA	Backflow preventer with controllable reduced pressure zone	•	•	•	•	—
CA	Backflow preventer with different non controllable pressure zones	•	•	•	—	—
DA	In line anti-vacuum valve	○	○	○	—	—
DB	Pipe interrupter with atmospheric vent and moving element	○	○	○	○	—
DC	Pipe interrupter with permanent atmospheric vent	○	○	○	○	○
EA	Controllable anti-pollution check-valve	•	•	—	—	—
EB	Non controllable anti-pollution check-valve	Only for certain domestic uses (see Clause 6)				
EC	Controllable anti-pollution double check-valve	•	•	—	—	—
ED	Non controllable anti-pollution double check-valve	Only for certain domestic uses (see Clause 6)				
GA	Mechanical disconnecter direct actuated	•	•	•	—	—
GB	Mechanical disconnecter hydraulic actuated	•	•	•	•	—
HA	Hose union backflow preventer	•	•	○	—	—
HB	Shower hose union anti-vacuum valve	○	○	—	—	—
HC	Automatic diverter	Only for certain domestic uses (see Clause 6)				
HD	Hose union anti-vacuum valve combined with a check-valve	•	•	○	—	—
LA	Pressurized air inlet valve	○	○	—	—	—
LB	Pressurized air inlet valve combined with a check-valve located downstream	•	•	○	—	—
General remarks:						
Units with an atmospheric vent may not be installed where it is liable to flooding (for examples AA, BA, CA, GA, GB...).						
• Covers the risk						
○ Covers the risk only if p = atm						
— does not cover the risk						
* is not applicable						

6 Point of use protection for equipment at the draw-off point for domestic uses

6.1 Choice of the protection units to be implemented

The protection units of equipment installed at the point of use are analyzed according to the method described in Clause 5. Protection units, given in Table 3, are also allowed.

Table 3

Equipments	Category	Authorized level units
Tap with spray at hand basin, sink, shower, bath; excluding toilet, bidet	5	Protection units appropriate to Category 2 and EB, ED, HC
Bath with inlet below the edge of the tub ^b	5	Protection units appropriate to Category 3
Draw-off tap for hose connection ^{a,b}	5	Protection units appropriate to Category 3
Lawn irrigation system — buried system ^b	5	Protection units appropriate to Category 4
^a Used for washing, cleaning or garden watering.		
^b The installation of the protection unit must be above the maximum operational level.		

6.2 Location of the protection units

The protection assemblies shall be incorporated into the domestic equipment. If for specific technical reasons they are not, then they shall be installed at the connection of the supply of those installations so as to ensure the protection of the potable water.

7 Point of use protection of particular equipment for non domestic uses

Non domestic installations — because of their complexity — require a complete and detailed analysis in accordance with Clause 5.

If an analysis is not possible, an air gap of family A, type A, B or D is the only protection device to be used.

8 Protection at the connection point to the public potable water system

Technical analysis of the hazard is based on examination of the uses of water in the water system located downstream of the delivery point specified by the water supply authorities or regulations.

A backflow protection unit shall be installed at the origin of the potable water installations network at the appropriate place:

- for all domestic uses and for the non domestic uses where interior examination is possible and the guarantees sufficient, the protection unit shall be a controllable check-valve or check-valve integrated in the water meter;
- for non domestic uses where interior inspection is not possible and for those of which the guarantees are insufficient, the protection unit shall be chosen according to the maximum risk which can be caused by the use of the water.

9 Air break to drain

The air breaks to drain shall be realized by a full disconnection or by air inlets.

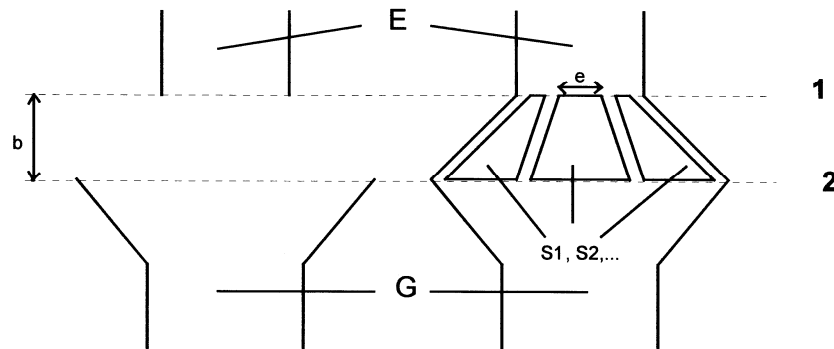

Key

1 Outlet evacuation

2 Spillover level

Evacuation E: bore E

Drain G: bore G

Air inlets: S1, S2 cross-sections for air passage

e: smallest dimension for calculation of a cross-section

Requirements

$b \geq G$

$b \geq 20 \text{ mm}$

$G \geq E$ and drain (G) shall be capable to take the full flow of the discharge

$e \geq 4 \text{ mm}$

$$S_1 + S_2 + \dots \geq \frac{b \times 2\pi G}{3}$$

Figure 1



Annex A
(normative)



Reference list of the protection units

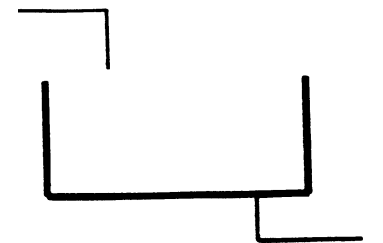
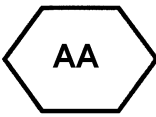
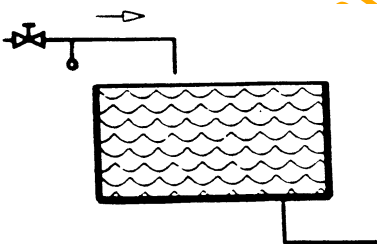
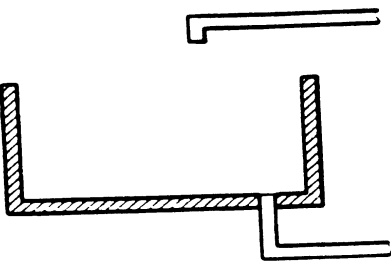

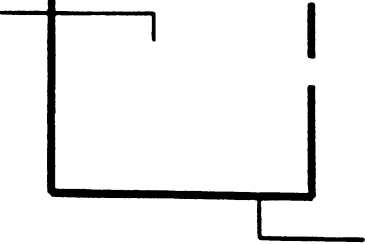
Family	Air gap	A
<p>Definition An air gap is a permanent unobstructed distance, whether outside or inside the receiving vessel, between the upstream potable water supply feed orifice and the downstream process fluid, measured at maximum operational level.</p>		
<p>Functional requirements To prevent the backflow of a contaminated fluid into the potable water supply system by means of a permanent unobstructive disconnection distance.</p>		

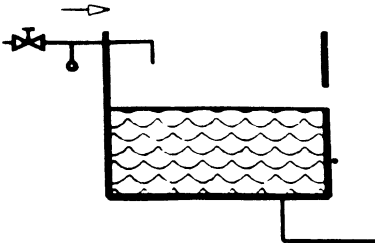
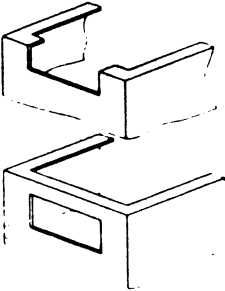

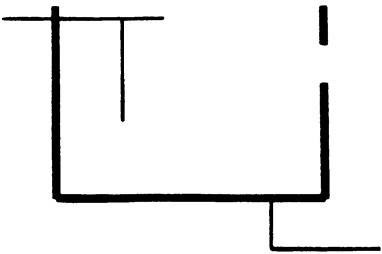
Draft for comments only — Not to be cited as East African Standard

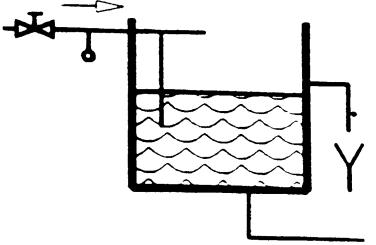
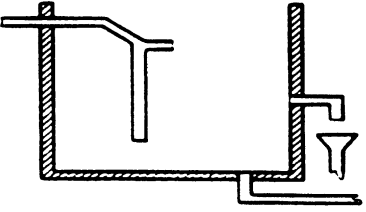

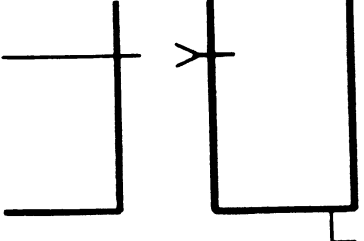
Family	Air gap	A
Type	Unrestricted air gap	A
 <p data-bbox="284 535 665 598">Figure A.1: Protection device — Graphic symbol</p>	 <p data-bbox="747 430 917 525">Figure A.2: Protection unit symbol</p>	 <p data-bbox="998 556 1356 619">Figure A.3: Protection unit — Graphic symbol</p>
 <p data-bbox="300 913 657 945">Figure A.4: Design principle</p>	<p data-bbox="706 640 812 672"><u>Definition</u></p> <p data-bbox="706 672 1372 819">An "AA" air gap is a visible unobstructed and complete air gap placed permanently and vertically between the lowest point of the inlet feed orifice and any surface of the receiving vessel that determines the maximum operational level at which the device overflows.</p>	
<p data-bbox="267 976 511 1008"><u>Product requirements</u></p> <p data-bbox="267 1008 1372 1060">The protection device shall conform to the national standard transposing the East African Standard as available.</p>		
<p data-bbox="267 1092 544 1123"><u>Installation requirements</u></p> <p data-bbox="267 1123 1372 1176">Every float-operated valve or other device that controls the flow of water to a receiving vessel shall be securely and rigidly fixed.</p> <p data-bbox="267 1207 1372 1260">Every feed pipe supplying water to such a valve or other device shall be fixed in its position to prevent it from moving or buckling.</p> <p data-bbox="267 1291 1372 1344">The direction of flow from a feed pipe into the receiving vessel with an air gap "AA" shall be into air at atmospheric pressure, downwards and not more than 15° from the vertical.</p> <p data-bbox="267 1375 1372 1459">No object shall be closer than three times the diameter of the feed pipe to the inlet pipe or to the vertical projection of the inlet or feed pipe between the pipe and the maximum operational level of the receiving vessel.</p> <p data-bbox="267 1491 1372 1543">Where non-circular pipes are used, the bore shall be taken as the internal diameter of a circular pipe having the same cross-sectional areas as the non-circular pipe.</p> <p data-bbox="267 1575 950 1606">The device shall not be installed in locations liable to flooding.</p>		

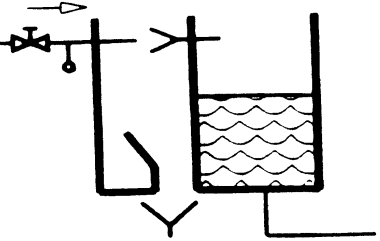
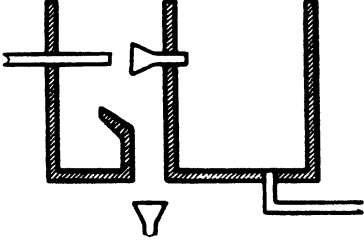
Family	Air gap	A
Type	Air gap with overflow non-circular (unrestricted)	B
 <p data-bbox="261 600 610 659">Figure A.5: Protection device — Graphic symbol</p>	 <p data-bbox="672 468 935 527">Figure A.6: Protection unit symbol</p>	 <p data-bbox="1003 615 1338 674">Figure A.7: Protection unit — Graphic symbol</p>
 <p data-bbox="245 1035 581 1066">Figure A.8: Design principle</p>	<p data-bbox="651 701 756 732"><u>Definition</u></p> <p data-bbox="651 758 1377 821">An "AB" air gap is a permanent and vertical distance between the lowest point of the feed orifice and the critical water level.</p> <p data-bbox="651 846 1377 930">The overflow shall be non-circular in design and capable of draining the maximum inflow of water under positive pressure fault condition.</p>	
<p data-bbox="245 1125 488 1157"><u>Product requirements</u></p> <p data-bbox="245 1182 1377 1241">The protection device shall conform to the national standard transposing the East African Standard as available</p>		
<p data-bbox="245 1272 521 1304"><u>Installation requirements</u></p> <p data-bbox="245 1329 1377 1392">Every float-operated valve or other device that controls the inflow of water to a receiving vessel shall be securely and rigidly fixed to that vessel.</p> <p data-bbox="245 1417 1377 1480">Every feed pipe supplying water to such a valve or other device shall be fixed in its position to prevent it from moving or buckling.</p> <p data-bbox="245 1505 1377 1568">The inlet device shall not come into contact in any way with a product from downstream, whether owing to backflow, bending or deformation of the assembly.</p> <p data-bbox="245 1593 930 1625">The device shall not be installed in locations liable to flooding.</p>		

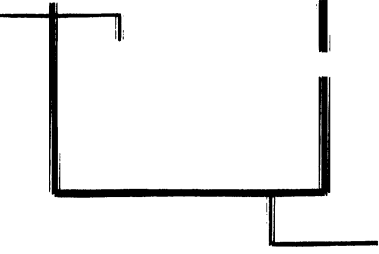

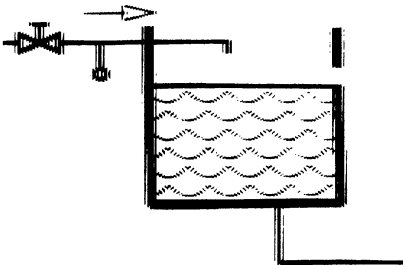
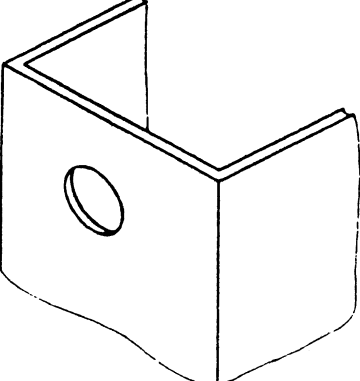
Family	Air gap	A
Type	Air gap with submerged feed incorporating air inlet plus overflow	C
 <p data-bbox="266 680 613 737">Figure A.9: Protection device — Graphic symbol</p>	 <p data-bbox="675 525 948 581">Figure A.10: Protection unit symbol</p>	 <p data-bbox="1003 680 1357 737">Figure A.11: Protection unit — Graphic symbol</p>
 <p data-bbox="266 1020 610 1050">Figure A.12: Design principle</p>	<p data-bbox="662 793 766 823"><u>Definition</u></p> <p data-bbox="662 852 1373 936">An "AC" air gap is a permanent and vertical distance between the lowest point of the air inlet orifice in the feed pipe and the critical water level.</p>	
<p data-bbox="246 1079 483 1108"><u>Product requirements</u></p> <p data-bbox="246 1138 1373 1192">The protection device shall conform to the national standard transposing the East African Standard as available</p>		
<p data-bbox="246 1255 522 1285"><u>Installation requirements</u></p> <p data-bbox="246 1314 1373 1369">Every float-operated valve or other device that controls the inflow of water to a receiving storage cistern shall be securely and rigidly fixed to that cistern.</p> <p data-bbox="246 1398 1373 1453">Every feed pipe supplying water to such a valve or other device shall be fixed in its position to prevent it from moving or buckling.</p> <p data-bbox="246 1482 928 1512">The device shall not be installed in locations liable to flooding.</p>		

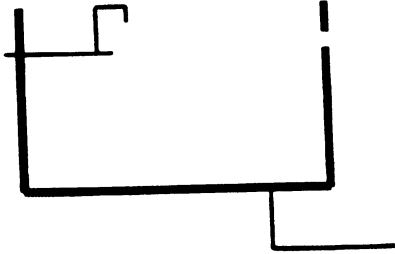
Family	Air gap	A
Type	Air gap with injector	D
 <p data-bbox="261 621 623 674">Figure A.13: Protection device — Graphic symbol</p>	 <p data-bbox="672 470 948 527">Figure A.14: Protection unit symbol</p>	 <p data-bbox="997 621 1354 674">Figure A.15: Protection unit — Graphic symbol</p>
 <p data-bbox="245 968 594 995">Figure A.16: Design principle</p>	<p data-bbox="662 709 769 737"><u>Definition</u></p> <p data-bbox="662 764 1377 848">An "AD" air gap with injector is a permanent air gap between the upstream feed orifice and the downstream device inlet orifice.</p>	
<p data-bbox="245 1024 488 1052"><u>Product requirements</u></p> <p data-bbox="245 1083 1377 1136">The protection device shall conform to the national standard transposing the East African Standard as available.</p>		
<p data-bbox="245 1199 521 1226"><u>Installation requirements</u></p> <p data-bbox="245 1257 1214 1285">Every valve or device that controls the inflow of water shall be securely and rigidly fixed.</p> <p data-bbox="245 1316 1377 1369">Every feed pipe supplying water to such a valve or other device shall be fixed in its position to prevent it from moving or buckling.</p> <p data-bbox="245 1400 927 1428">The device shall not be installed in locations liable to flooding.</p>		

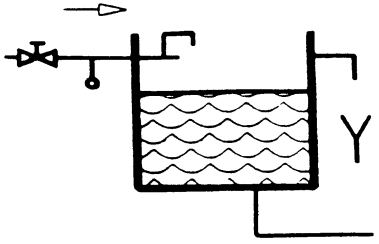
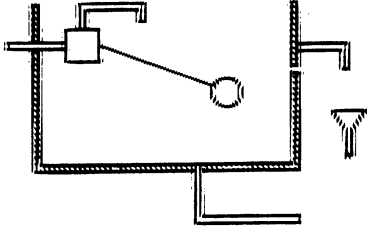

Family	Air gap	A
Type	Air gap with overflow circular (restricted)	F
 <p data-bbox="248 653 641 709">Figure A.17: Protection device — Graphic symbol</p>	 <p data-bbox="716 499 896 583">Figure A.18: Protection unit symbol</p>	 <p data-bbox="987 667 1356 724">Figure A.19: Protection unit — Graphic symbol</p>
 <p data-bbox="272 1182 620 1213">Figure A.20: Design principle</p>	<p data-bbox="669 783 776 814"><u>Definition</u></p> <p data-bbox="669 842 1377 898">An "AF" air gap is a permanent and vertical distance between the lowest point of the feed orifice and the critical water level.</p> <p data-bbox="669 926 1377 1010">The overflow shall be circular in design and capable of draining the maximum inflow of water under positive pressure fault condition.</p>	
<p data-bbox="248 1272 488 1304"><u>Product requirements</u></p> <p data-bbox="248 1331 1377 1388">The protection device shall conform to the national standard transposing the East African Standard as available.</p>		
<p data-bbox="248 1444 521 1476"><u>Installation requirements</u></p> <p data-bbox="248 1503 1377 1560">Every float-operated valve or other device that controls the inflow of water to a receiving vessel shall be securely and rigidly fixed to that vessel.</p> <p data-bbox="248 1587 1377 1644">Every feed pipe supplying water to such a valve or other device shall be fixed in its position to prevent it from moving or buckling.</p> <p data-bbox="248 1671 1377 1728">The inlet device shall not come into contact in any way with a product from downstream, whether owing to backflow, bending or deformation of the assembly.</p> <p data-bbox="248 1755 930 1787">The device shall not be installed in locations liable to flooding.</p>		

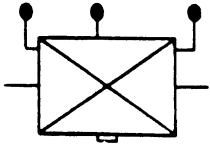
<p>Family Type</p>	<p>Air gap Air gap with overflow tested by vacuum measurement</p>	<p>A G</p>
 <p>Figure A.21: Protection device — Graphic symbol</p>	 <p>Figure A.22: Protection unit symbol</p>	 <p>Figure A.23: Protection unit Graphic symbol</p>
 <p>Figure A.24: Design principle</p>	<p><u>Definition</u> An "AG" air gap is a permanent and vertical distance between the lowest point of the feed orifice and the critical water level.</p>	
<p><u>Product requirements</u></p> <p>The protection device shall conform to the national standard transposing the East African Standard as available.</p>		
<p><u>Installation requirements</u></p> <p>Every float-operated valve or other device that controls the inflow of water to a receiving vessel shall be securely and rigidly fixed to that vessel.</p> <p>Every feed pipe supplying water to such a valve or other device shall be fixed in its position to prevent it from moving or buckling.</p> <p>The inlet device shall not come into contact in any way with a product from downstream, whether owing to outlet orifice backflow, bending or deformation of the assembly. The device shall not be installed in locations liable to flooding.</p>		

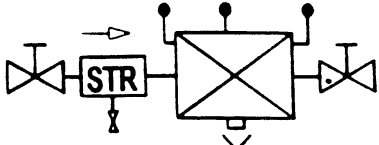
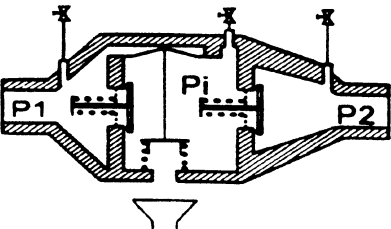
Family	Controllable disconnection	B
<p><u>Definition</u></p> <p>Disconnection is artificially provided by the action or the reaction of one or more hydromechanical interlock devices, in alternating or simultaneous situation, to upstream pressure changes (pressure drop or negative pressure) and downstream pressure changes (back pressure) in combination with a tightness defect of the downstream check-valve.</p>		
<p><u>Functional requirements</u></p> <p>Devices within this family are characterized by:</p> <ul style="list-style-type: none"> — three pressure zones such that upstream $p_1 >$ intermediate $p_i >$ downstream p_2 (static no flow and under water flow conditions); — a positive differential pressure $p_1 - p_i$ under static and dynamic condition; — an automatic discharge linked to the intermediate zone; — three pressure tappings allowing regular verification of functioning; — a given discharge flow rate. <p>They are fitted with air breaks to drain.</p> <p>The protection devices shall be capable of working without modification or adjustment.</p>		

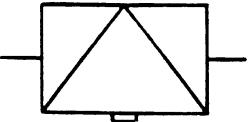

Family	Controllable disconnection	B
Type	Backflow preventer with controllable reduced pressure zone	A
 <p>Figure A.25: Protection device — Graphic symbol</p>	 <p>Figure A.26: Protection unit symbol</p>	 <p>Figure A.27: Protection unit — Graphic symbol</p>
 <p>Figure A.28: Design principle</p>	<p><u>Definition</u></p> <p>The specific characteristics of the "BA" device are as follows:</p> <ul style="list-style-type: none"> — $p_1 - p_i > 14 \text{ kPa}$ (140 mbar); — connection of the intermediate pressure zone (p_i) to the atmosphere when $p_1 - p_i < 14 \text{ kPa}$ (140 mbar); — disconnection by venting the intermediate pressure zone (p_i) to the atmosphere when p_1 will be up to 14 kPa (140 mbar); — a minimum set discharge flow (backflow rate); — devices that allow verification in every zone of the disconnection and the sealing of the protection devices (obturators, discharge valves). 	
<p><u>Product requirements</u></p> <p>The protection device shall conform to the national standard transposing the East African Standard as available.</p>		
<p><u>Installation requirements</u></p> <p>The device shall be readily accessible.</p> <p>It shall not be installed in locations liable to flooding.</p> <p>It shall be installed in an aerated environment (unpolluted atmosphere).</p> <p>The drain shall be capable of taking the discharge.</p> <p>It shall be protected against frost or excessive temperature.</p> <p>It shall be installed horizontally, with the discharge valve opening downwards. Pressure taps shall make it possible to carry out inspection test without difficulty.</p> <p>It can be installed only for potential backflows not exceeding the discharge capacity of the protection device.</p>		

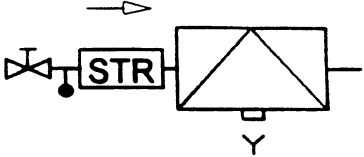
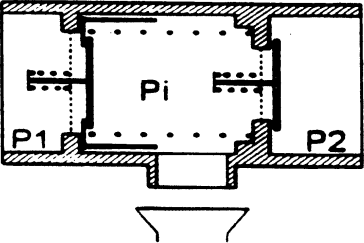

Family	Non controllable disconnection	C
<p><u>Definition</u></p> <p>Disconnection is artificially provided by the action or reaction of one or more mechanical interlock devices, in alternating or simultaneous situations, to upstream pressure changes (negative pressure) and downstream pressure changes (counter pressure), in combination with a tightness defect of the downstream check-valve.</p>		
<p><u>Functional requirements</u></p> <p>Devices within this family are characterized by:</p> <ul style="list-style-type: none"> — three pressure zones, at normal flow $p_1 > p_i > p_2$; — an intermediate zone venting to the atmosphere when the intermediate (P_i) pressure reaches a value higher than the inlet pressure within a fixed percentage; — a given discharge flow rate; — no means are provided for the occasional or continuous verification of values controlling operation of the safety devices; — an automatic discharge linked to the intermediate zone. <p>They are fitted with air breaks to drain.</p> <p>The protection devices shall be capable of working without modification or adjustment.</p>		

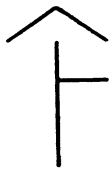

Family	Non controllable disconnection	C
Type	Backflow preventer with different non-controllable pressure zones	A
 <p>Figure A.29: Protection device — Graphic symbol</p>	 <p>Figure A.30: Protection unit symbol</p>	 <p>Figure A.31: Protection unit — Graphic symbol</p>
 <p>Figure A.32: Design principle</p>	<p><u>Definition</u> The CA device is divided into three zones:</p> <ul style="list-style-type: none"> — one upstream zone p_1; — one intermediate zone (p_i, not measurable) vented to the atmosphere; — one downstream zone p_2. <p>The device provides disconnection by venting the intermediate pressure zone to the atmosphere when the difference of pressure between the intermediate zone and the upstream zone is less than 10 % of the upstream pressure ($p_i - p_1 < 10 \% p_1$).</p> <p>It ensures a discharge flow (backflow rate) through the intermediate zone, at least equal to the given discharge flow rate.</p> <p>Means for the control of the protection device are not included.</p>	
<p><u>Product requirements</u></p> <p>The protection device shall conform to the national standard transposing the East African Standard as available</p>		
<p><u>Installation requirements</u></p> <p>The device shall be readily accessible.</p> <p>It shall not be installed in locations liable to flooding.</p> <p>It shall be installed in an aerated environment (unpolluted atmosphere).</p> <p>The drain shall be capable of taking the discharge.</p> <p>It shall be protected against frost or excessive temperature.</p>		

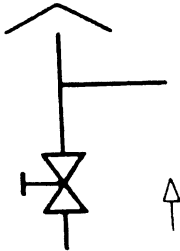
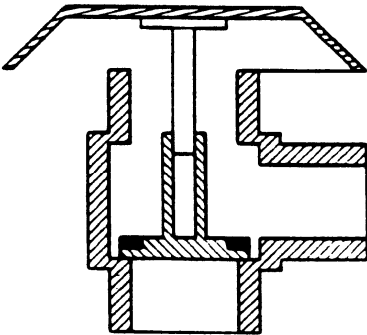
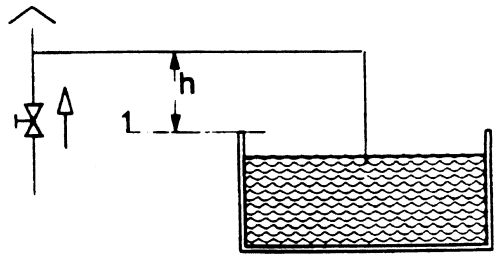
Family	Atmospheric venting principle	D
<p><u>Definition</u> Disconnection is provided naturally by atmospheric pressure.</p>		
<p><u>Functional requirements</u></p> <p>This family is characterized by:</p> <ul style="list-style-type: none"> — an air inlet device which opens in the event of the flow ceasing or negative pressure in the feed pipe in accordance with given dimensional characteristics. The requirements of the air inlet port will be satisfied by the vacuum test and by minimum dimensional requirements in the appropriate product standard; — when in a static situation the obligation to ensure a permanent vertical air gap between the air inlet and the maximum downstream level fluid. <p>No load nor permanent back-pressure shall be caused by the downstream installation.</p>		

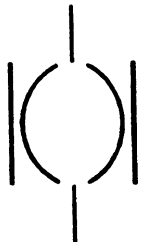
Draft for comments only — Not to be cited as East African Standard

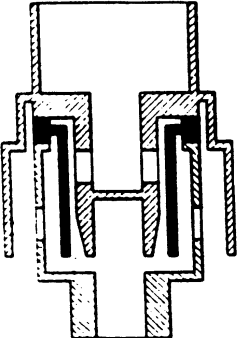
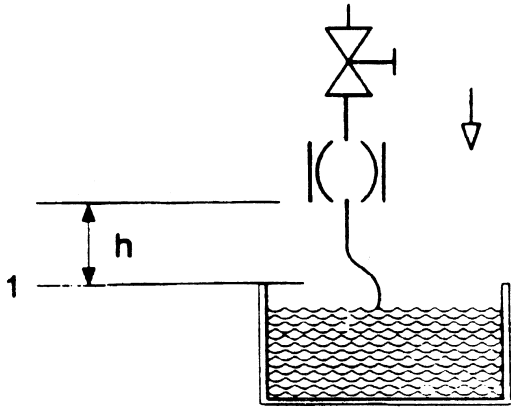

Family	Atmospheric venting principle	D
Type	In line anti-vacuum valve	A
 <p>Figure A.33: Protection device — Graphic symbol</p>	 <p>Figure A.34: Protection unit symbol</p>	 <p>Figure A.35: Protection unit — Graphic symbol</p>
 <p>Figure A.36: Design principle</p>	<p><u>Definition</u></p> <p>Mechanical device with an air inlet that is closed when water flows through it at or above atmospheric pressure, but that opens to admit air if there is a subatmospheric pressure at the water inlet or when flow stops, and closes so as to be watertight when the flow of water is resumed at normal pressure.</p> <p>In case of subatmospheric pressure the obturator as well as admitting air to the downstream pipework also throttles the inlet waterway of the device.</p> <p>It ensures protection against back siphonage only by draining to the atmosphere, but not against back pressure.</p>	
<p><u>Functional requirements</u></p> <p>The protection device shall conform to the national standard transposing the East African Standard as available.</p>		
<p><u>Installation requirements</u></p> <p>$h > 300$ mm above the maximum downstream level fluid;</p> <p>No closure device shall be installed after the DA.</p> <p>The diameter of the device shall correspond to the dimensions of the connected installation system.</p> <p>The device shall be readily accessible.</p> <p>It shall not be installed in locations liable to flooding.</p> <p>It shall be installed in an aerated environment (unpolluted atmosphere).</p> <p>It shall be protected against frost or excessive temperature</p>	 <p>Key 1 Maximum downstream level</p> <p>Figure A.37: Installation</p>	

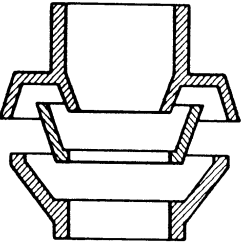
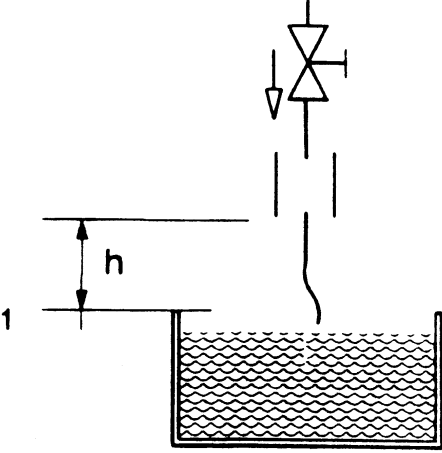

Family	Atmospheric venting principle	D
Type	Pipe interrupter with atmospheric vent and moving element	B
 <p>Figure A.38: Protection device — Graphic symbol</p>	 <p>Figure A.39: Protection unit symbol</p>	 <p>Figure A.40: Protection unit Graphic symbol</p>
 <p>Figure A.41: Design principle</p>	<p><u>Definition</u></p> <p>Pipe interrupters with elastic membrane are fitted with air inlet port(s) that are closed, when water flows through it above atmospheric pressure, but that open to admit air if there is a subatmospheric pressure at the water inlet or when the flow stops, and close to be watertight when the flow of water is resumed at normal pressure.</p> <p>It ensures protection against back siphonage only by draining to the atmosphere, but not against back pressure. Direction of water flow is vertically downwards.</p>	
<p><u>Product requirements</u></p> <p>The protection device shall conform to the national standard transposing the East African Standard as available.</p>		
<p><u>Installation requirements</u></p> <p>$h > 150$ mm above the maximum downstream level fluid;</p> <p>No closure device shall be installed after the DB.</p> <p>The diameter of the device shall correspond to the dimensions of the connected installation system;</p> <p>The device shall be readily accessible.</p> <p>It shall not be installed in locations liable to flooding.</p> <p>It shall be installed in an aerated environment (unpolluted atmosphere).</p> <p>It shall be protected against frost or excessive temperature</p>	 <p>Key 1 Maximum downstream level</p> <p>Figure A.42: Installation</p>	

Family	Atmospheric venting principle	D
Type	Pipe interrupter with permanent atmospheric vent	C
 <p data-bbox="272 661 581 716">Figure A.43: Protection device — Graphic symbol</p>	 <p data-bbox="646 527 977 581">Figure A.44: Protection unit symbol</p>	 <p data-bbox="1029 661 1360 716">Figure A.45: Protection unit — Graphic symbol</p>
 <p data-bbox="250 1031 604 1060">Figure A.46: Design principle</p>	<p data-bbox="630 779 737 808"><u>Definition</u></p> <p data-bbox="630 835 1377 919">Pipe interrupters with permanent atmospheric vent are fitted with air inlet port(s) that are totally unrestricted and permanent. Water flows vertically downwards.</p> <p data-bbox="630 947 1377 1010">The device prevents back flow by venting to atmosphere all the downstream and upstream elements.</p>	
<p data-bbox="245 1094 488 1123"><u>Product requirements</u></p> <p data-bbox="245 1150 1377 1213">The protection device shall conform to the national standard transposing the East African Standard as available.</p>		
<p data-bbox="245 1268 521 1297"><u>Installation requirements</u></p> <p data-bbox="245 1325 800 1381">$h > 150$ mm above the maximum downstream level fluid.</p> <p data-bbox="245 1409 786 1438">No closure device shall be installed after the DC.</p> <p data-bbox="245 1465 800 1549">The diameter of the device shall correspond to the dimensions of the connected installation system.</p> <p data-bbox="245 1577 675 1606">The device shall be readily accessible.</p> <p data-bbox="245 1633 800 1696">It shall not be installed in locations liable to flooding.</p> <p data-bbox="245 1724 800 1787">It shall be installed in an aerated environment (unpolluted atmosphere).</p> <p data-bbox="245 1814 800 1877">It shall be protected against frost or excessive temperature.</p>	 <p data-bbox="824 1717 862 1747">Key</p> <p data-bbox="824 1766 1052 1795">1 Maximum downstream</p> <p data-bbox="954 1822 1247 1852">Figure A.47: Installation</p>	

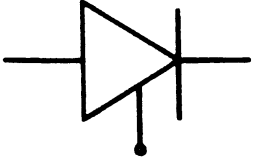

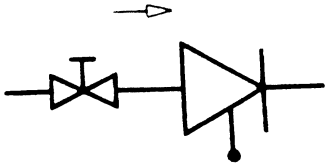
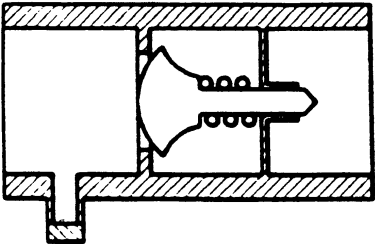
Family	Anti-pollution check-valves	E
<p><u>Definition</u> A mechanical protection device to permit flow in one direction only.</p> <p>It will open automatically when the pressure in the direction of flow upstream of the valve is greater than the pressure downstream. In cases when the pressure is higher downstream or no flow condition exists the valve is closed by anticipation acting under a force.</p>		
<p><u>Functional requirements</u></p> <p>The protection device, for $\varnothing \leq 50$ mm, shall be able to function in any position.</p>		

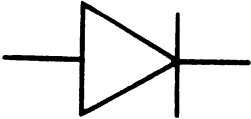
Draft for comments only — Not to be cited as East African Standard

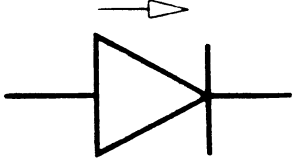
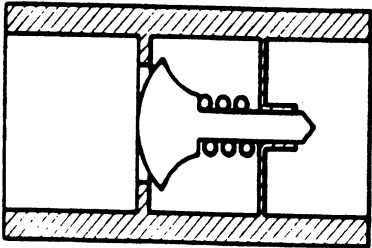

Family	Anti-pollution check-valves	E
Type	Controllable anti-pollution check-valves	A
 <p data-bbox="256 569 646 625">Figure A.48: Protection device — Graphic symbol</p>	 <p data-bbox="699 510 976 562">Figure A.49: Protection unit symbol</p>	 <p data-bbox="1036 569 1365 625">Figure A.50: Protection unit — Graphic symbol</p>
 <p data-bbox="277 951 626 982">Figure A.51: Design principle</p>	<p data-bbox="678 688 789 716"><u>Definition</u></p> <p data-bbox="678 741 1377 800">A controllable mechanical protection device, equipped with one obturator, to permit flow in one direction only.</p> <p data-bbox="678 831 1377 1003">It will open automatically when the pressure in the direction of flow upstream of the valve is greater than the pressure downstream. When the pressure is higher downstream or no flow condition exists the valve is closed by anticipation acting under a force for example of a mechanical assembly or a spring.</p>	
<p data-bbox="245 1062 488 1089"><u>Product requirements</u></p> <p data-bbox="245 1119 1377 1178">The protection device shall conform to the national standard transposing the East African Standard as available.</p>		
<p data-bbox="245 1234 521 1262"><u>Installation requirements</u></p> <p data-bbox="245 1291 675 1318">The device shall be readily accessible.</p> <p data-bbox="245 1348 902 1375">It shall be protected against frost or excessive temperature.</p>		

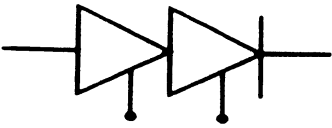
<p>Family</p>	<p>Anti-pollution check-valves</p>	<p>E</p>
<p>Type</p>	<p>Non controllable anti-pollution check-valve, incl. cartridge</p>	<p>B</p>
<div style="text-align: center;">  </div> <p>Figure A.52: Protection device — Graphic symbol</p>	<div style="text-align: center;">  </div> <p>Figure A.53: Protection unit symbol</p>	<div style="text-align: center;">  </div> <p>Figure A.54: Protection unit — Graphic symbol</p>
<div style="text-align: center;">  </div> <p>Figure A.55: Design principle</p>	<p><u>Definition</u></p> <p>A non controllable mechanical protection device (including cartridge), equipped with one obturator, to permit flow in one direction only.</p> <p>It will open automatically when the pressure in the direction of flow upstream of the valve is greater than the pressure downstream. When the pressure is higher downstream or no flow condition exists the valve is closed by anticipation acting under a force for example of a mechanical assembly or a spring.</p>	
<p><u>Product requirements</u></p> <p>The protection device shall conform to the national standard transposing the East African Standard as available.</p>		
<p><u>Installation requirements</u></p> <p>The device shall be readily accessible. It shall be protected protection against frost or excessive temperature.</p>		

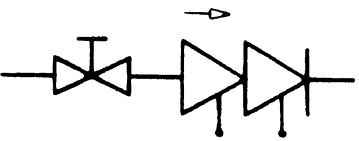
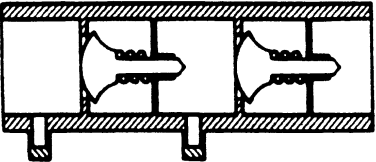

Draft for comments only — Not to be cited as East African Standard

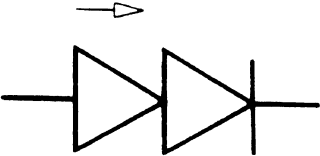
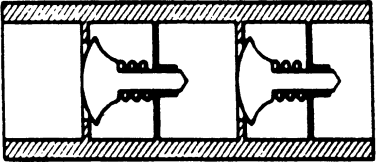

<p>Family</p>	<p>Anti-pollution check-valves</p>	<p>E</p>
<p>Type</p>	<p>Controllable anti-pollution double check-valve</p>	<p>C</p>
 <p>Figure A.56: Protection device — Graphic symbol</p>	 <p>Figure A.57: Protection unit symbol</p>	 <p>Figure A.58: Protection unit — Graphic symbol</p>
 <p>Figure A.59: Design principle</p>	<p><u>Definition</u></p> <p>A controllable mechanical protection device, equipped with two independent acting obturators, to permit flow in one direction only.</p> <p>It will open automatically when the pressure in the direction of flow upstream of the valve is greater than the pressure downstream. When the pressure is higher downstream or no flow condition exists the valve is closed by anticipation acting under a force for example of a mechanical assembly or a spring.</p>	
<p><u>Product requirements</u></p> <p>The protection device shall conform to the national standard transposing the East African Standard as available.</p>		
<p><u>Installation requirements</u></p> <p>The device shall be readily accessible.</p> <p>It shall be protected against frost or excessive temperature.</p>		

Draft for comments only — Not to be cited as East African Standard

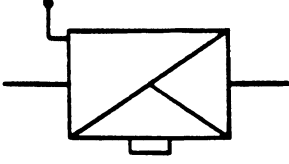
<p>Family</p>	<p>Anti-pollution check-valves</p>	<p>E</p>
<p>Type</p>	<p>Non controllable anti-pollution double check-valve</p>	<p>D</p>
 <p>Figure A.60: Protection device — Graphic symbol</p>	 <p>Figure A.61: Protection unit symbol</p>	 <p>Figure A.62: Protection unit — Graphic symbol</p>
 <p>Figure A.63: Design principle</p>	<p><u>Definition</u></p> <p>A non controllable mechanical protection device, equipped with two independent acting obturators, to permit flow in one direction only.</p> <p>It will open automatically when the pressure in the direction of flow upstream of the valve is greater than the pressure downstream. When the pressure is higher downstream or no flow condition exists the valve is closed by anticipation acting under a force e.g. of a mechanical assembly or a spring.</p>	
<p><u>Product requirements</u></p> <p>The protection device shall conform to the national standard transposing the East African Standard as available.</p>		
<p><u>Installation requirements</u></p> <p>The device shall be readily accessible.</p> <p>It shall be protected against frost or excessive temperature.</p>		

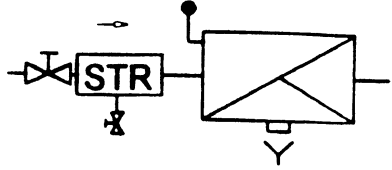
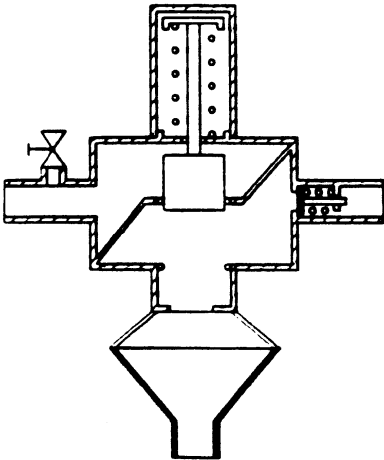
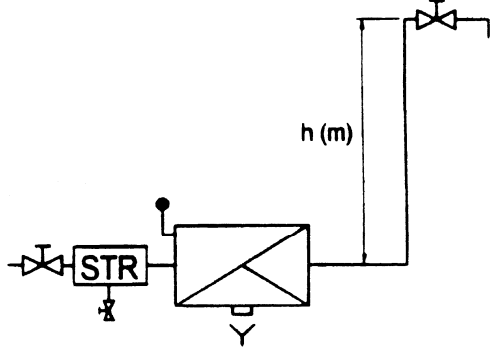

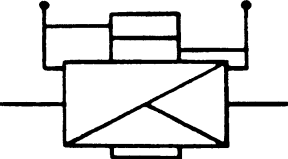
Family	Controllable mechanical disconnection	G
<p><u>Definition</u></p> <p>The disconnection is achieved by one or more hydromechanical locking devices. A disconnector family G is characterized by:</p> <ul style="list-style-type: none"> — two pressure zones in flow position: upstream and downstream; — three zones in drain position (zero-flow): upstream, intermediate and downstream; — a determined relief flow rate; — a drain position visible directly or by a position indicator. 		
<p><u>Functional requirements</u></p> <p>For a disconnector family G, the drain position is being achieved by the force of a prestressed spring. The relief valve starts opening:</p> <ul style="list-style-type: none"> — for type A, when the set pressure $p_s \geq p_{stat} + 50 \text{ kPa}$ (0.5 bar) is achieved, — or by type B, when the differential pressure $p_1 - p_2 \geq 15 \text{ kPa}$ (0.15 bar). At zero flow the drain position shall be open irrespective of the actual differential pressure. 		

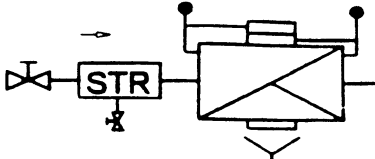
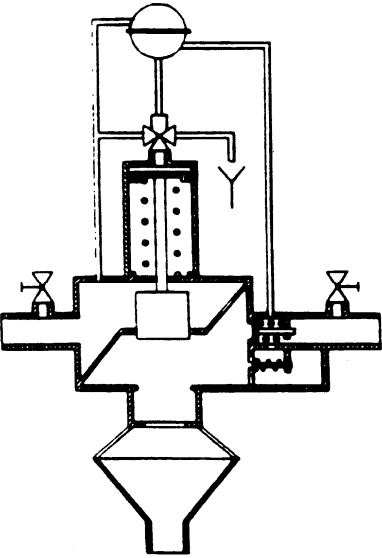

<p>Family</p>	<p>Controllable mechanical disconnection</p>	<p>G</p>
<p>Type</p>	<p>Mechanical disconnector direct actuated</p>	<p>A</p>
 <p>Figure A.64: Protection device — Graphic symbol</p>	 <p>Figure A.65: Protection unit symbol</p>	 <p>Figure A.66: Protection unit — Graphic symbol</p>
 <p>Figure A.67: Design principle</p>	<p><u>Definition</u></p> <p>A direct actuated disconnector GA is characterized by:</p> <ul style="list-style-type: none"> — two pressure zones in flow position: upstream and downstream; — three zones in drain position (zero flow): upstream, intermediate and downstream. The upstream spring loaded obturator with discharge system and the downstream check-valve separate the intermediate zone from the upstream and downstream zone; — flow position is achieved at a pressure $p_f \leq p_s + 50 \text{ kPa}$ (0.5 bar); — the relief valve starts opening at the set pressure $P_s + P_{stat} + 50 \text{ kPa}$ (0.5 bar); — drain position is achieved at a pressure $p_0 \geq p_s - 36 \text{ kPa}$ (0.36 bar); — a determined relief flow rate; — a drain position visible directly or by a position indicator. 	
<p><u>Functional requirements</u></p> <p>The protection device shall conform to the national standard transposing the East African Standard as available.</p>		
<p><u>Installation requirements</u></p> <p>The device shall be readily accessible.</p> <p>It shall not be installed in locations liable to flooding.</p> <p>It shall be installed in an aerated environment (unpolluted atmosphere).</p> <p>The drain shall be capable of taking the discharge.</p> <p>It shall be protected against frost or excessive temperature.</p> <p>Spring = $[h(m) + 5(m)]$.</p>	 <p>Figure A.68: Installation</p>	

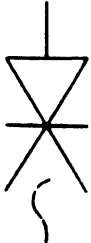

<p>Family</p>	<p>Controllable mechanical disconnection</p>	<p>G</p>
<p>Type</p>	<p>Mechanical disconnector hydraulic actuated</p>	<p>B</p>
 <p>Figure A.69: Protection device — Graphic symbol</p>	 <p>Figure A.70: Protection unit symbol</p>	 <p>Figure A.71: Protection unit — Graphic symbol</p>
 <p>Figure A.72: Design principle</p>	<p><u>Definition</u></p> <p>A hydraulic actuated disconnector GB is characterized by:</p> <ul style="list-style-type: none"> — two pressure zones in flow position: upstream downstream; and — three zones in drain position (zero-flow): upstream, intermediate and downstream. The upstream spring loaded obturator with discharge system and the downstream check-valve separate the intermediate zone from the upstream and downstream zone; — at zero flow the disconnector shall be in drain position; — the relief valve start opening at a pressure difference between upstream and downstream zone $\Delta p > 15 \text{ kPa}$ (0.15 bar); — flow position is achieved at a pressure difference $\Delta p < 100\text{kPa}$(1 bar) — a determined relief flow rate; — a drain position visible directly or by a position indicator. 	
<p><u>Functional requirements</u></p> <p>The protection device shall conform to the national standard transposing the East African Standard as available.</p>		
<p><u>Installation requirements</u></p> <p>The device shall be readily accessible.</p> <p>It shall not be installed in locations liable to flooding.</p> <p>It shall be installed in an aerated environment (unpolluted atmosphere).</p> <p>The drain shall be capable of taking the discharge.</p> <p>It shall be protected against frost or excessive temperature.</p> <p>The protection device shall be installed horizontally, with the discharge valve opening downwards. Pressure taps shall make it possible to carry out inspection test without difficulty.</p> <p>It can be installed only for potential backflows not exceeding the discharge capacity of the protection device</p>		

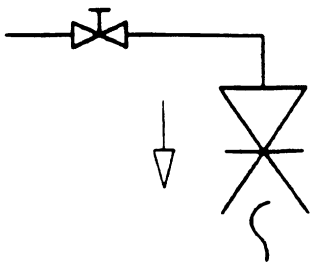
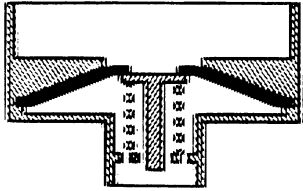
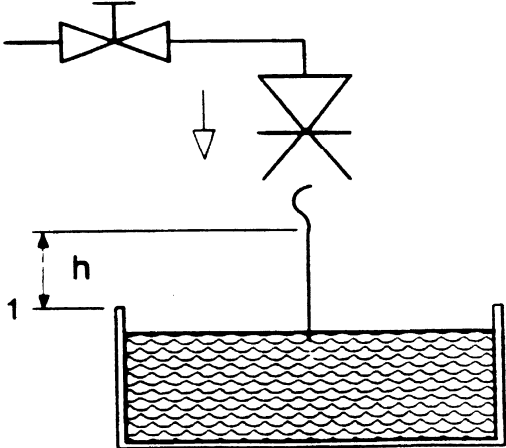
Family	Disconnection at the outlet	H
<p><u>Definition</u></p> <p>Disconnection is provided either by atmospheric pressure or by reaction of a mechanical device</p>		
<p><u>Functional requirements</u></p> <p>The family is characterized by an unrestricted air inlet at zero flow or vacuum.</p> <p>The vacuum tests specified in the product standards will show whether or not the air inlet port satisfy the requirements.</p> <p>No load or permanent back-pressure shall be caused by the downstream installation. It shall not be possible to block the air inlets easily.</p>		

Draft for comments only — Not to be cited as East African Standard

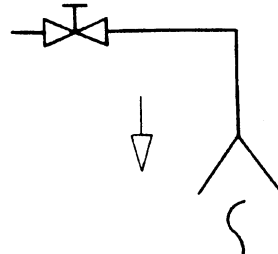
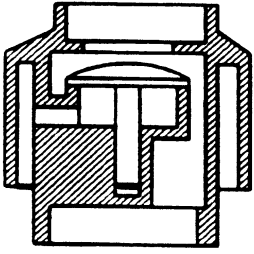
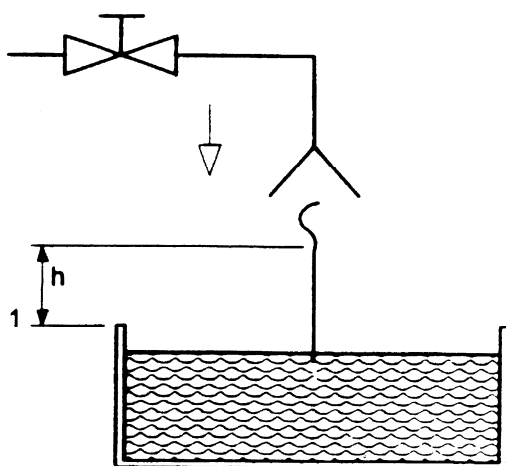
Family	Disconnection at the outlet	H
Type	Hose union backflow preventer	A
 <p>Figure A.73: Protection device — Graphic symbol</p>	 <p>Figure A.74: Protection unit symbol</p>	 <p>Figure A.75: Protection unit — Graphic symbol</p>
 <p>Figure A.76: Design principle</p>	<p><u>Definition</u></p> <p>Two pressure zones are separated by a check-valve.</p> <p>The check is closed at zero flow and the air inlets are open.</p> <p>Normal operation flow of water: check-valve is open; air inlets closed.</p>	
<p><u>Product requirements</u></p> <p>The protection device shall conform to the national standard transposing the East African Standard as available.</p>		
<p><u>Installation requirements</u></p> <p>The device shall not be exposed to continuous back-pressure.</p> <p>The downstream pipe shall be flexible and removable.</p> <p>It shall be installed in vertical position. The device shall be readily accessible.</p> <p>It shall not be installed in locations liable to flooding.</p> <p>It shall be protected against frost or excessive temperature.</p> <p>$h > 200$ mm above the maximum downstream level fluid</p>	 <p>Key 1 Maximum downstream level</p> <p>Figure A.77: Installation</p>	

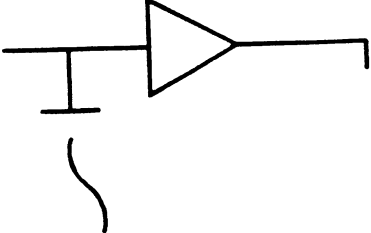

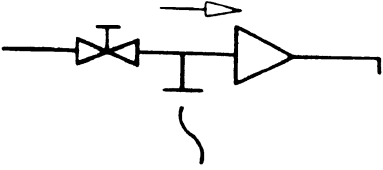
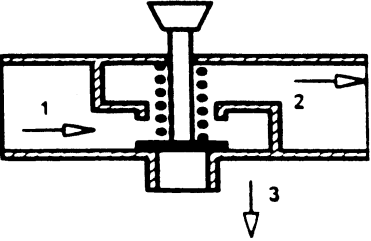
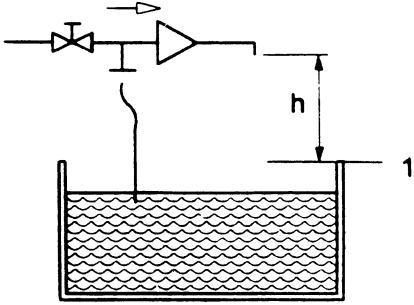
Family	Disconnection at the outlet	H
Type	Hose union anti-vacuum valve	B
 <p>Figure A.78: Protection device — Graphic symbol</p>	 <p>Figure A.79: Protection unit symbol</p>	 <p>Figure A.80: Protection unit — Graphic symbol</p>
 <p>Figure A.81: Design principle</p>	<p><u>Definition</u></p> <p>Movable part closing air vents at normal operation and zero flow.</p> <p>In case of vacuum in the supply line movable part will act similar as a check-valve and throttle the supply pipe.</p>	
<p><u>Product requirements</u></p> <p>The protection device shall conform to the national standard transposing the East African Standard as available.</p>		
<p><u>Installation requirements</u></p> <p>The device shall not be exposed to continuous back-pressure.</p> <p>The downstream pipe shall be flexible and removable.</p> <p>It shall be installed in vertical installation. The device shall be readily accessible.</p> <p>It shall not be installed in locations liable to flooding.</p> <p>It shall be installed in an aerated environment (unpolluted atmosphere).</p> <p>It shall be protected against frost or excessive temperature.</p> <p>No closure device shall be installed after HB.</p> <p>$h > 250$ mm above the maximum downstream level fluid.</p>	 <p>Key 1 Maximum downstream level</p> <p>Figure A.82: Installation</p>	

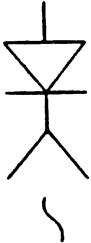
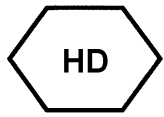
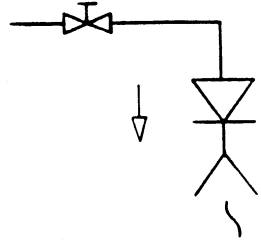
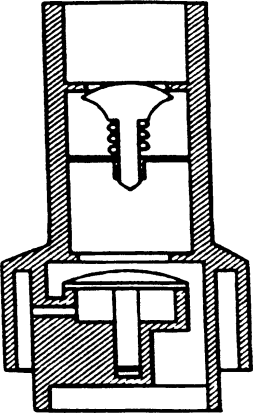
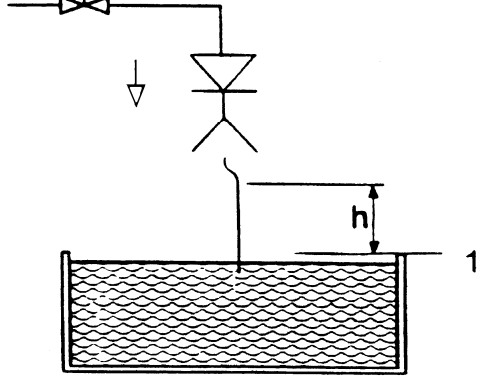

Family	Disconnection at the outlet	H
Type	Automatic diverter	C
 <p data-bbox="250 638 643 695">Figure A.83: Protection device — Graphic symbol</p>	 <p data-bbox="675 504 951 560">Figure A.84: Protection unit symbol</p>	 <p data-bbox="997 575 1357 632">Figure A.85: Protection unit — Graphic symbol</p>
 <p data-bbox="261 995 631 1022">Figure A.86 — Design principle</p>	<p data-bbox="670 699 776 726"><u>Definition</u></p> <p data-bbox="670 753 1122 781">Diverts to shower after manual actuation.</p> <p data-bbox="670 814 1377 871">Returns to spout mode automatically and disconnects by venting to atmosphere in the case of:</p> <ul data-bbox="670 898 1360 982" style="list-style-type: none"> — flow of water is stopped intentionally; — vacuum is applied from supply side. Spout acts as air inlet. 	
<p data-bbox="250 1062 483 1089"><u>Product requirements</u></p> <p data-bbox="250 1104 1377 1161">The protection device shall conform to the national standard transposing the East African Standard as available</p>		
<p data-bbox="250 1178 521 1205"><u>Installation requirements</u></p> <p data-bbox="250 1220 802 1276">The shower outlet shall not be connected to a rigid pipe.</p> <p data-bbox="250 1291 802 1348">It shall be installed downstream of a closing valve.</p> <p data-bbox="250 1362 675 1390">The device shall be readily accessible.</p> <p data-bbox="250 1404 802 1461">It shall not be installed in locations liable to flooding.</p> <p data-bbox="250 1476 802 1533">It shall be installed in an aerated environment (unpolluted atmosphere).</p> <p data-bbox="250 1547 802 1604">It shall be protected against frost or excessive temperature.</p> <p data-bbox="250 1619 802 1675">$h > 25$ mm above the maximum downstream level fluid.</p>	 <p data-bbox="824 1514 1114 1556">Key 1 Maximum downstream level</p> <p data-bbox="959 1583 1243 1610">Figure A.87: Installation</p>	

Family	Disconnection at the outlet	H
Type	Hose union anti-vacuum valve combined with a check-valve	D
 <p data-bbox="259 667 568 724">Figure A.88: Protection device — Graphic symbol</p>	 <p data-bbox="633 529 909 588">Figure A.89: Protection unit symbol</p>	 <p data-bbox="982 667 1347 724">Figure A.90: Protection unit — Graphic symbol</p>
 <p data-bbox="300 1207 535 1270">Figure A.91: Design principle</p>	<p data-bbox="609 787 722 814"><u>Definition</u></p> <p data-bbox="609 840 1347 871">It is a combination of a check-valve EB and anti-vacuum valve HB.</p> <p data-bbox="609 903 852 930"><u>Product requirements</u></p> <p data-bbox="609 955 1372 1018">The protection device shall conform to the national standard transposing the East African Standard as available.</p>	
<p data-bbox="243 1312 527 1339"><u>Installation requirements</u></p> <p data-bbox="243 1354 860 1407">The device shall not be exposed to continuous back-pressure.</p> <p data-bbox="243 1423 844 1455">The downstream pipe shall be flexible and removable.</p> <p data-bbox="243 1470 860 1522">It shall be installed in vertical installation. The device shall be readily accessible.</p> <p data-bbox="243 1539 820 1570">It shall not be installed in locations liable to flooding.</p> <p data-bbox="243 1585 860 1638">It shall be installed in an aerated environment (unpolluted atmosphere).</p> <p data-bbox="243 1654 860 1707">It shall be protected against frost or excessive temperature.</p> <p data-bbox="243 1722 747 1753">No closure device shall be installed after HD.</p> <p data-bbox="243 1770 860 1822">$h > 250$ mm above the maximum downstream level fluid.</p>	 <p data-bbox="876 1701 1169 1753">Key 1 Maximum downstream level</p> <p data-bbox="982 1774 1274 1806">Figure A.92: Installation</p>	

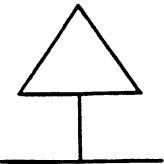
Family	Pressurized air inlet valve opening under vacuum	L
<p><u>Definition</u></p> <p>Pressurized in line air inlet valves are fitted with air inlet port(s) which is normally closed, when the water is above or equal to atmospheric pressure in the valve. The valve opens to admit air if there is a subatmospheric pressure at the water inlet, and closes to be watertight when the flow of water is resumed at normal pressure.</p>		
<p><u>Functional requirements</u></p> <p>The requirements of the air inlet port will be satisfied by the vacuum test and by minimum dimensional requirements in the appropriate product standard.</p>		

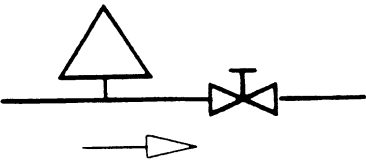
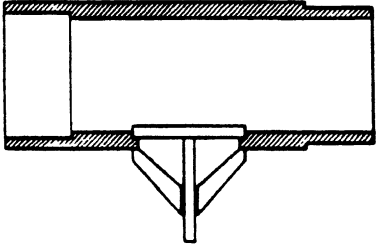
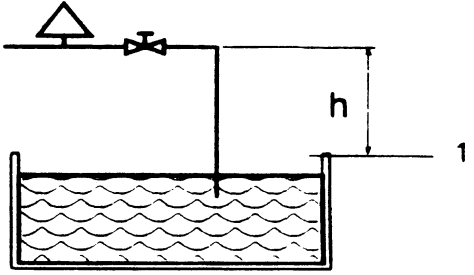
Draft for comments only — Not to be cited as East African Standard

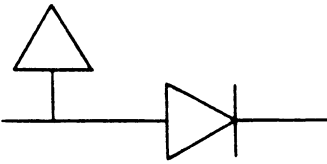
<p>Family</p>	<p>Pressurized air inlet valve opening under vacuum</p>	<p>L</p>
<p>Type</p>	<p>Pressurized air inlet valve</p>	<p>A</p>
 <p>Figure A.93: Protection device — Graphic symbol</p>	 <p>Figure A.94: Protection unit symbol</p>	 <p>Figure A.95: Protection unit — Graphic symbol</p>
 <p>Figure A.96: Design principle</p>	<p><u>Definition</u></p> <p>Pressurized in line air inlet valves are fitted with an air inlet port element which is normally closed, when the water is above or equal to atmospheric pressure in the valve. The valve opens to admit air if there is a subatmospheric pressure at the water inlet, and closes to be watertight when the flow of water is resumed at normal pressure.</p>	
<p><u>Product requirements</u></p> <p>The protection device shall conform to the national standard transposing the East African Standard as available.</p>		
<p><u>Installation requirements</u></p> <p>$h > 300$ mm above the maximum downstream level fluid.</p> <p>The diameter of the device shall correspond to the dimensions of connected installation system.</p> <p>The device shall be readily accessible.</p> <p>It shall not be installed in locations liable to flooding.</p> <p>It shall be installed in an aerated environment (unpolluted atmosphere).</p> <p>It shall be protected against frost or excessive temperature</p>	 <p>Key 1 Maximum downstream level</p> <p>Figure A.97: Installation</p>	

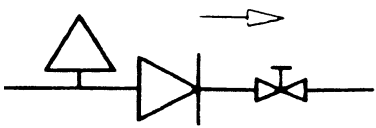
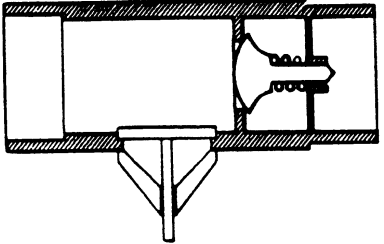
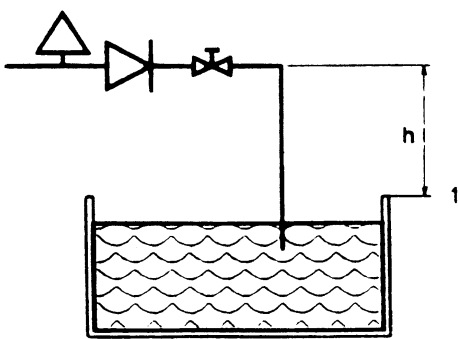
<p>Family</p>	<p>Pressurized air inlet valve opening under vacuum</p>	<p>L</p>
<p>Type</p>	<p>Pressurized air inlet valve combined with a check-valve located downstream</p>	<p>B</p>
 <p>Figure A.98: Protection device — Graphic symbol</p>	 <p>Figure A.99: symbol Protection unit</p>	 <p>Figure A.100: Protection unit — Graphic symbol</p>
 <p>Figure A.101: Design principle</p>	<p><u>Definition</u></p> <p>Pressurized in line air inlet valves are fitted with an air inlet port element which is normally closed, when the water is above or equal to atmospheric pressure in the valve. The valve opens to admit air if there is a subatmospheric pressure at the water inlet, and closes to be watertight when the flow of water is resumed at normal pressure.</p> <p>"LB" is a "LA" with an integrated check-valve of type "EB" located downstream.</p>	
<p><u>Product requirements</u></p> <p>The protection device shall conform to the national standard transposing the East African Standard as available.</p>		
<p><u>Installation requirements</u></p> <p>$h > 300$ mm above the maximum downstream level fluid.</p> <p>The diameter of the device shall correspond to the dimensions of connected installation system.</p> <p>The device shall be readily accessible.</p> <p>It shall not be installed in locations liable to flooding.</p> <p>It shall be installed in an aerated environment (unpolluted atmosphere).</p> <p>It shall be protected against frost or excessive temperature</p>	 <p>Key 1 Maximum downstream level</p> <p>Figure A.102: Installation</p>	

Annex B
(informative)

Guide table for determining the fluid category from which protection is required

Table B.1

1	Water intended for human consumption	Category
1.1	Potable water	1
1.2	High pressure water ²⁾	1
1.3	Stagnant water	2
1.4	Chilled water	2
1.5	Sanitary hot water	2
1.6	Steam (in contact with foods, free of additives)	2
1.7	Conditioned water ³⁾	2
2	Water with additives or in contact with liquid or solid elements other than those of Category 1	Category
2.1	Softened water not intended for human consumption	3/4 ⁴⁾
2.2	Water + anti-corrosion not intended for human consumption	3/4 ⁴⁾
2.3	Water + anti-freeze	3/4 ⁴⁾
2.4	Water + algacide	3/4 ⁴⁾
2.5	Water + liquid foodstuffs (fruit juice, coffee, non-alcoholic, soups)	2
2.6	Water + solid foods	2
2.7	Water + alcoholic drink	2
2.8	Water + washing products	3/4 ⁴⁾
2.9	Water + surfactants	3/4 ⁴⁾
2.10	Water + disinfectants not intended for human consumption	3/4 ⁴⁾
2.11	Water + detergents	3/4 ⁴⁾
2.12	Water + refrigerant	3/4 ⁴⁾
3	Water from other uses	Category
3.1	Food cooking water	2
3.2	Washing water for fruit, vegetables (catering system)	3/5 ⁵⁾
3.3	Prewashing and washing water for dishes, cooking utensils	5
3.4	Rinsing water for dishes, cooking utensils	3
3.5	Central heating water without additives	3
3.6	Sewer, waste	5
3.7	Body washing water	5
3.8	Toilet cistem water	3
3.9	WC water	5
3.10	Animal drinking water	5
3.11	Swimming pool water	5
3.12	Cloth washing water	5
3.13	Sterile water	2
3.14	Demineralized water	2

¹⁾ Some elements can increase the risks (temperature, materials....).

²⁾ Conditioned water inside buildings (excluding equipment).

³⁾ The border between Category 3 and Category 4 is in principle LD 50 = 200 mg/kg body weight in reference to EU Directive 93/21/EEC dated April 27th, 1993.

Annex C
(informative)

Summary of the analysis method

- List the fittings and appliances that could cause backflow.
- Ascertain which are the installation characteristics to be taken into account in accordance with 5.3:
 - a) to select the location where the protection unit is to be placed and disregard it if already existing;
 - b) to determine the maximum fault level. The combination of items a) and b) determines if the situation at the point of protection is $p = \text{atm}$ or $p > \text{atm}$.
- Draw up the installation matrix in accordance with 5.6.
- Consider which are the protection units to be used by referring to the protection matrix according to 5.8 and clauses 6 and 7.
- Determine if the separation walls are protecting or not, in accordance with 5.4.
- Verify if the drainage systems are fitted with an air break to drain in accordance with 5.5.

Check whether these protection units are present. In this case, the equipment may be connected directly, otherwise, make provision for them either in the equipment or upstream of it.

Bibliography

The method described in this standard is based on the EUREAU (European Union of National Associations of Water Suppliers), document titled: "Protection against pollution. Analysis method of risks and choices of appropriate devices" and published in 1985. This method is currently named "Montout method", after the name of the author.

Draft for comments only — Not to be cited as East African Standard

Draft for comments only — Not to be cited as East African Standard

Draft for comments only — Not to be cited as East African Standard